



**Metric**



## TOUGH PRODUCTS FOR TOUGH APPLICATIONS

For **100 years**, Power Team has been the cornerstone of safety and reliability in high-pressure hydraulic tools. Power Team enables the creation and upkeep of concentrated force delivery solutions, including lifting, lowering, pushing, pulling, clamping, spreading, and torquing activities.

The Power Team portfolio features hydraulic pumps, cylinders, shop equipment, heavy lifting and positioning equipment, jacks, tools, and system components. This comprehensive Power Team portfolio meets the critical needs of the construction, automotive assembly, mining, shipbuilding, manufacturing, and industrial processing sectors.

With rugged design, protective coatings, and robust materials, Power Team equipment can withstand the rigors of the most demanding industrial applications.

The Power Team portfolio is rounded out with repair and maintenance services that deliver ongoing functional reliability. In addition, Power Team offers on-site safety training to support the well-being of its customers' workforces in potentially hazardous environments.

- TABLE OF CONTENTS -

	<p><b>CYLINDERS</b> 5-42</p>	
	<p><b>PUMPS</b> 43-110</p>	
	<p><b>HYDRAULIC ACCESSORIES</b> 111-144</p>	
	<p><b>SHOP EQUIPMENT</b> 145-162</p>	
	<p><b>JACKS</b> 163-184</p>	
	<p><b>HYDRAULIC &amp; MECHANICAL TOOLS</b> 185-218</p>	
	<p><b>PULLERS</b> 219-260</p>	

Powerthon  
**Limited**  
**Lifetime**  
**WARRANTY**  
ISO 9001 Certified

Worry-Free  
Ownership

2025 Hydraulic Technologies, LLC. All rights reserved. Every effort has been made to assure the accuracy of product descriptions in this catalog at the time of printing. Hydraulic Technologies reserves the right to modify or discontinue products without prior notice, alter or amend any published specification without notice. Hydraulic Technologies trade-names, trademarks, or any part of the document or any of its contents may not be copied, reproduced, transmitted, modified or used, in whole or in part, without the express prior written consent of Hydraulic Technologies.

"Power Team", "Vanguard Jr.", "Quarter Horse", "Flame-out", "Posi-Check", "Roll-Bed", "Power-Twin" are registered trademarks of Hydraulic Technologies.

**RESOURCES**  
261-277



Table listing various part numbers and their corresponding page numbers, organized in multiple columns.



**B**  
BP212VQ.....74

**C**  
C51C.....9, 12, 209, 275  
C53C.....9, 12, 275  
C55C.....9, 12, 52, 229, 230, 231, 275  
C55CBT.....9, 13, 275  
C57C.....9, 12, 209, 275  
C59C.....9, 12, 275  
C101C.....9, 12, 209, 275  
C102C.....9, 12, 52, 275  
C104C.....9, 12, 275  
C106C.....9, 12, 52, 177, 229, 230, 231, 275  
C108C.....9, 12, 275  
C115C.....9, 12, 275  
C152C.....9, 12, 275  
C154C.....9, 12, 52, 275  
C156C.....9, 12, 52, 275  
C158C.....9, 12, 275  
C251C.....9, 12, 209, 275  
C252C.....9, 12, 275  
C254C.....9, 12, 275  
C256C.....9, 12, 52, 149, 178, 275  
C258C.....9, 12, 275  
C308C.....9, 12  
C552C.....9, 12, 275  
C554C.....9, 12, 275  
C556C.....9, 12, 52, 135, 136, 153, 275  
C756C.....9, 12, 275  
C1002C.....9, 12, 275  
C1006C.....9, 12, 52, 275  
C1010C9, 12, 52, 150, 209, 248, 275  
C1012C.....9, 12, 275  
C1014C.....9, 12, 275  
C1016C.....9, 12, 275  
C1150C.....9, 12, 229, 230, 231, 275  
C1512C.....9, 12, 275  
C1514C.....9, 12, 275  
C1516C.....9, 12, 275  
C2510C.....9, 12, 275  
C2512C.....9, 12, 275  
C2514C.....9, 12, 52, 135, 136, 152, 209, 229, 230, 231, 275  
C2514CBT.....9, 13  
C5510C.....9, 12, 275  
C5513C.....9, 12, 135, 136, 153, 229, 230, 231, 275  
C7513C.....9, 12, 275  
C10010C.....9, 11, 12, 135, 136, 154, 254, 275  
CBS55.....175  
CBS100.....175  
CBS150.....175  
CBS200.....175  
C05.....209, 210  
C010.....209, 210  
C025.....209, 210

**D**  
DFTAS000001.....188, 189, 197  
DFTAS000002.....188, 189, 197, 198

**E**  
ES14PRTXA - ES64PRTX.....104

**F**  
FC2200.....161, 162  
FC4400.....161, 162  
FK59.....49  
FK159B.....51  
FLS15.....205, 206  
FLS15-ST.....205

**H**  
HFS3A.....207  
HFS6A.....207  
HNS150.....204  
HNS150A.....204  
HNS225.....204  
HP35.....186, 211, 212  
HP35P-220.....212  
HP35S.....211, 212  
HP35SP-E220.....212  
HS2000.....172, 177, 178, 208  
HS3000.....208  
HST11.....220, 246  
HST11S.....245  
HT75.....213  
HT200.....213, 215  
HTS50.....218

**I**  
IM10B.....172  
IM10E.....172  
IM10H.....172  
IM10L.....172

**J**  
J24T.....171  
J55T.....171  
J106T.....171  
JAM10033.....176  
JAM15033.....176  
JAR10033.....176  
JEM5526.....175, 176  
JEM15026.....176  
JM25 - JM420.....176

**K**  
K82.....220, 246  
K83.....220, 246

**L**  
LM4D-E.....140  
LM4S-E.....140

**M**  
MB5.....178, 252  
MB8.....252  
MB16.....252  
MCS.....44, 105, 106

**N**  
NRP9 - NRP-60K.....201

**P**  
P12.....8, 46, 48, 49, 52, 125, 139  
P19.....8, 46, 48, 49  
P19L.....46, 48, 50, 177, 206, 230  
P23.....46, 48, 49, 125  
P55.....8, 46, 48, 49, 52, 125, 139, 150, 248, 250  
P59.....8, 46, 48, 49, 52, 125, 139, 149, 151, 172  
P59F.....8, 46, 48, 49  
P59L.....46, 48, 50, 172, 178, 230  
P59L-1500.....50  
P59L-1500G.....50  
P157.....8, 46, 48, 51, 125  
P157D.....46, 51, 125  
P159.....8, 46, 48, 51, 52, 125, 152, 153, 230  
P159D.....46, 51, 125  
P300.....8, 46, 48, 51, 125  
P300D.....46, 51, 125  
P460.....8, 46, 48, 51, 52, 117, 118, 119, 120, 153, 154, 230  
P460D.....46, 51  
PA68.....44, 46, 48, 53, 54, 55, 126, 151, 152, 153  
PA62.....53, 54, 126  
PA6A.....54, 126  
PA6AM.....54  
PA6D.....44, 55, 56, 118, 120, 126  
PA6D2.....56, 126  
PA6DM.....56  
PA6DM-1.....56  
PA6DM-2.....56  
PA6M.....53, 54  
PA6M-1.....53, 54  
PA6M-2.....54  
PA6R.....54, 126  
PA6RM.....54  
PA9.....8, 44, 46, 48, 57, 58  
PA9H.....57, 58, 150  
PA50.....44, 46, 61, 62, 126  
PA50D.....61, 62  
PA50M.....61  
PA50R.....62, 126  
PA50R2.....61, 62, 126  
PA64.....46, 59, 60, 92, 126  
PA172.....46, 63, 64, 118, 126  
PA174.....46, 63, 64, 126  
PA462.....46, 65, 66  
PA464.....46, 66  
PA464R.....46, 66  
PA464RA.....66  
PA554.....46, 65, 66, 126  
PB43MA1P-1.....67, 68  
PB43MA2P-1.....68  
PB43MA2PE-1.....104  
PB43MA2PE-2.....104  
PB43MA2PE-3.....104  
PB43MA2PE-4.....104  
PB43MD1P-1 - PB43ML2P-1.....68  
PB43MX2-1.....101, 102, 123  
PB43MX2-2.....101, 102  
PB43MX2-3.....101, 102  
PB43MX2-4.....101, 102  
PH53CR.....247  
PH63C.....220, 245  
PH82K.....245, 267  
PH83C.....220, 245, 246  
PH103C.....248  
PH103CR.....248  
PH113C.....220, 245, 246  
PH172.....247, 248, 258  
PH303.....247, 248  
PH303C.....220, 245  
PH303R.....248  
PH503.....248  
PH553CL.....253  
PH1002.....254  
PH1002-E220.....254  
PH1002J.....254  
PMPH8.....251  
PMPH8-1.....251  
PMPH8R.....251  
PMA.....176  
PMA55.....176  
PMA55S.....175, 176  
PME.....176  
PME55.....176  
PME55S.....175, 176  
PPH17.....250, 257, 258  
PPH17R.....250  
PPH30.....250, 257, 258  
PPH30R.....250  
PPH50.....249, 250, 258  
PPH50R.....250  
PQ120.....8, 33, 44, 47, 48, 79, 91-94, 118-126, 154-158

PQ120-220.....154  
PQ120-E380.....154  
PQ603.....91, 92  
PQ603S.....92  
PQ604.....91, 92  
PQ604S.....91, 92, 155, 157  
PQ1203-E380.....94  
PQ1203S-E380.....94  
PQ1204-E380.....94  
PQ1204S-E380.....93, 94, 154, 155, 156, 158  
PR102.....74  
PR102A.....74  
PR104.....73, 74  
PR2100J.....255, 256  
PR2100J-E220.....255  
PR2100S.....255, 256  
PR2100S-E220.....255  
PR3100J.....255, 256  
PR3100J-E380.....255  
PR3100S.....255, 256  
PR3100S-E380.....255  
PT102.....223, 226, 227  
PT103.....223, 226, 227  
PT104.....223, 226, 227  
PT105.....225, 227  
PT106.....223, 226  
PT108.....223, 226  
PT108L.....223  
PT108XL.....223  
PT110.....223, 226  
PT110L.....223, 226  
PT111.....223, 226  
PT113L.....223, 226  
PT115L.....223, 226  
PT116L.....223, 226  
PT202.....223, 226, 227  
PT203.....223, 226, 227  
PT204.....223, 226, 227  
PT205.....223, 226, 227  
PT206.....223, 226, 227  
PT208.....223, 226  
PT208XL.....223  
PT210.....223, 226  
PT210L.....223, 226  
PT213.....223, 226  
PT213L.....223, 226  
PT216.....223, 226  
PT216L.....223, 226  
PT10554L.....225, 227  
PT10561.....224, 225, 227  
PT10562.....224, 225, 227  
PT10563.....224, 225, 227  
PT10661.....224, 225  
PTAT-1104 - PTATN-5.....159  
PTRF-104K.....228  
PTHP-1.....228  
PTHP-2.....228  
PTM-AT1104.....159  
PTM-AT1108.....159  
PTMPS16.....226  
PTP4.....223, 224, 226, 227  
PTP6.....223, 224, 226, 227  
PTP10.....223, 224, 226, 227  
PTP13.....223, 226  
PTP16.....223, 226  
PTP50T.....232  
PTPH-100TDA-E220.....234  
PTPH-100T-E220.....234  
PTPH-102TDA-E220.....234  
PTPH-102TDA-E220.....234  
PTPH-102T-E220.....234  
PTPH-102TV-E220.....234  
PTPH-1131E.....238  
PTPH-123TDA-E220.....234  
PTPH-123T-E220.....234  
PTPH-200T-E220.....236  
PTPHB-106E - PTPHB-213LE.....229  
PTPHC-106E - PTPHC-213LE.....230  
PTPHD-106E-E220.....231  
PTPHD-213LE-E220.....231  
PTPHS-108 - PTPHS-208XL.....237  
PTPM4 - PTPM6.....226  
PTPM6.....225  
PTPMW-1.....227  
PTPT-2550.....229, 230, 231  
PTTB-1045.....227  
PTTJ-1 - PTTJ-3.....224  
PTTJ-107.....227  
PTU1020.....160  
PTU1022 - PTUW8.....160  
PTX4.....223, 224, 227  
PTX6.....223, 224  
PTX10.....223, 224

**R**  
R552C.....9, 35  
R552L.....9, 40, 275  
R556C.....9, 35  
R556L.....9, 40, 275  
R1002.....9, 35  
R1002D.....9, 36, 275  
R1002L.....10, 40, 275  
R2802D.....10, 36, 275  
R2802L.....10, 40, 275  
R2806C.....10, 35, 275  
R2806D.....10, 36, 275  
R2806L.....10, 40, 275  
R3552C.....10, 35, 275  
R3552D.....10, 36, 275  
R3552L.....10, 40, 275  
R3556C.....10, 35, 275  
R3556D.....10, 36, 275  
R3556L.....10, 40, 275  
R4302C.....10, 35, 275  
R4302D.....10, 36, 275  
R4302L.....10, 40, 275  
R4306C.....10, 35, 275  
R4306D.....10, 36, 275  
R4306L.....10, 40, 275  
R5510C.....9, 35  
R5510L.....9, 40, 275  
R5652C.....10, 35, 275  
R5652D.....10, 36, 275  
R5652L.....10, 40, 275  
R5656C.....10, 35, 275  
R5656D.....10, 36, 275  
R5656L.....10, 40, 275  
R10010D.....9, 36, 275  
R10010L.....9, 40, 275  
R15010C.....10, 35, 275  
R15010L.....10, 40, 275  
R20010D.....10, 36, 275  
R20010L.....10, 36, 275  
R28010L.....10, 40, 275  
R35510C.....10, 35, 275  
R43010D.....10, 36, 275  
R43010L.....10, 40, 275  
R56510C.....10, 35, 275  
R56510L.....10, 36, 275  
RA202 - RA10010.....9, 17, 39, 275  
RB8013S-E380.....158  
RB10013S.....157, 158  
RB10013S-E380.....158  
RB15013S-E380.....158  
RB20013S-E380.....158  
RC2GAL.....126  
RC5.....126  
RC12V.....74  
RD106.....9, 15, 34, 67, 275  
RD256.....9, 15, 34, 275  
RD300.....9, 34, 275  
RD556.....9, 33, 34, 275  
RD1006.....9, 34, 275  
RD1010.....9, 15, 34, 150, 275  
RD1506.....10, 34, 275  
RD2006.....10, 34, 275  
RD2514.....9, 15, 34, 152, 275  
RD3006.....10, 34, 95, 275  
RD4006.....10, 34, 275  
RD5006.....10, 34, 275  
RD5513.....9, 34, 79, 85, 153, 275  
RD5518.....9, 34, 275  
RD8013.....9, 34, 139, 158, 275  
RD10013.....9, 33, 34, 154, 158, 275  
RD10020.....9, 34, 275  
RD15013.....10, 34, 156, 158, 275  
RD15018.....10, 34, 275  
RD20013.....10, 34, 156, 158, 275  
RD20018.....10, 34  
RD30013.....10, 34, 275  
RD40013.....10, 34, 275  
RD50013.....10, 30, 31, 32  
RDG552 - RDG600.....14, 30, 37, 275  
RGG552 - RGG60014.....9, 10, 26, 28, 276  
RGL552 - RGL2008.....37  
RGL2502 - RGL5008.....38  
RGL5510 - RGL5512.....37  
RGL6002 - RGL6008.....38  
RGL7510 - RGL20012.....37  
RGL25010 - RGL60012.....38  
RGP672 - RGP5652.....41  
RH102.....9, 21, 22, 276  
RH108.....9, 21, 22, 276  
RH120.....9, 21, 276  
RH121.....9, 21, 276  
RH121T.....9, 21, 276  
RH123.....9, 21, 276  
RH202.....9, 21, 22, 24, 52, 276  
RH206.....9, 21, 276  
RH302.....9, 21, 22, 24, 178, 276  
RH303.....9, 21, 22, 24, 276  
RH306.....9, 21, 22, 24, 276  
RH306D.....9, 21, 22, 276  
RH503.....9, 21, 22, 24, 276  
RH603.....9, 21, 22, 24, 276  
RH605.....9, 21, 22, 24, 276  
RH606.....9, 21, 24, 276  
RH1006.....9, 22, 276  
RH1009.....9, 21, 22, 276  
RH1505.....9, 22, 276  
RH1508.....10, 22, 276  
RH2008.....10, 22, 65, 276  
RH3010.....9, 22, 276  
RH6010.....9, 22, 139, 276  
RH10010.....9, 22, 276  
RHA20.....24  
RHA30.....24  
RHA50.....24

RHA100.....24  
RHA306.....9, 21, 276  
RH6040D.....9, 22, 276  
RJ100T24A.....173  
RJ100T24A-C.....173  
RJ100T24E.....173  
RJ100T24E-C.....173  
RJ100T24E-E.....173  
RJ100T37A.....173  
RJ100T37A-C.....173  
RJ100T37A-E.....173  
RJ100T37E.....173, 267  
RJ100T37E-C.....173  
RJ100T37E-E.....173  
RJ-CB1 - RJ-CB10.....174  
RJ-EXT5 - RJ-EXT-S1.....173, 174  
RJ-SC1 - RJ-SP-S.....174  
RLS50 - RLS1500S.....9, 18, 178, 276  
RP20.....126  
RP20-F.....126  
RP20M.....126  
RP20M-F.....126  
RP21.....126  
RP22.....110, 126  
RP25.....9, 14, 276  
RP50.....92, 110, 126  
RP51.....92, 126  
RP55.....9, 14, 276  
RP100.....110, 126  
RP101.....92, 110, 126  
RP103.....92, 126  
RP104.....126  
RPS55 - RPS1010.....52, 248  
RPS2514.....52  
RSS101.....9, 19, 177, 276  
RSS202.....9, 19, 20, 52, 178, 276  
RSS302.....9, 19, 20, 52, 276  
RSS1002.....9, 19, 20, 52, 276  
RSS1002D.....9, 19, 276  
RSS2503.....10, 19, 276  
RT172.....9, 23, 24, 139, 248, 250, 276  
RT302.....9, 23, 24, 139, 248, 250, 276  
RT503.....9, 23, 24, 139, 248, 250, 276  
RT1004.....9, 23, 24, 139, 276  
RV1278.....116, 130  
RV21278-6 - RV21278-6280.....130  
RWP55.....186, 203  
RWP55-A.....203

**S**  
SB15.....206  
SJ2010 - SJ3010P.....179, 180  
SK10TE.....177  
SK25TE.....178  
SP1010A.....150  
SPA256.....151  
SPA556.....153  
SPA2514.....152  
SPE256.....151  
SPE256-E220.....153  
SPE556.....151  
SPE1010D.....153  
SPE1010D-E220.....150  
SPE2514DS-E220.....152  
SPE2514-E220.....152  
SPE5513S-E220.....153  
SPE5513DS.....153  
SPE5513DS-E220.....153  
SPE5513E220.....153  
SPE10010-E220.....154  
SPE10010R-E220.....154  
SPE10013DS.....154  
SPE10013DS-E380.....154  
SPE15013DS-E380.....156  
SPE20013DS.....155, 156  
SPE20013DS-E380.....156  
SPH1010-E220.....150  
SPM256.....151  
SPM256C.....159  
SPM556.....153  
SPM1010.....150  
SPM2514.....152  
SPM5513.....153  
SPM10010.....154  
SS2.....220, 243

**T**  
TWH15.....137  
TWH15E.....191  
TWH20.....137  
TWH20E.....191  
TWH30.....137  
TWH30E.....191  
TWHC1 - TWHC50.....187-190  
TWL2-026 - TWL30-500.....192-194  
TWL2C.....189, 191-195, 198  
TWL2C-RP.....195  
TWL2C-RR.....195  
TWL2C-SP.....195  
TWL2C-TWLC30-RP.....189, 191, 192, 193, 195, 197, 198  
TWL2-041032 - TWR30-500463.....192  
TWL2-032 - TWL2-060.....198  
TWL4-046 - TWL4-080.....197, 198

# CYLINDERS

FROM  
**2**  
TO  
**1497**  
TONS!

## SUPERIOR FEATURES OF POWER TEAM HYDRAULIC CYLINDERS:

We build our own cylinders in our ISO 9001 registered manufacturing facilities. All Power Team cylinders are date coded and stamped with a maximum pressure rating and capacity. Each cylinder we make complies with the demanding ASME B30.1 standard and are assembled/tested by certified assemblers and pressure tested to 125% of capacity before leaving our factories. Some other key features included:

- Cylinder bores are roller burnished to harden and smooth the surface, improving seal life by 30%.
- Base mounting holes withstand full cylinder capacity.
- Typical cylinder burst pressure range is from 1750 to 2450 bar, well-beyond extreme usage.
- Cylinders with gland nuts may be “dead-ended” at 700 bar.
- Eddy current and mag-particle inspections detect flaws in the steel.
- Material is removed from surface to ensure that any flaws are eliminated.



Powerthon  
Limited  
**Lifetime**  
WARRANTY  
ISO 9001 Certified

Worry-Free  
Ownership



	<b>Page Description</b>	<b>Cylinder Movement</b>	<b>Type of Return</b>	<b>Tonnage Range</b>	<b>Page(s)</b>
	<b>Introduction</b>	-	-	-	<b>5-10</b>
	<b>C</b>	Single-Acting	Spring	4,5-91	<b>11-12</b>
	<b>CBT</b>	Single-Acting	Spring	4,5-25	<b>13</b>
	<b>RP</b>	Single-Acting	Spring	2-4,5	<b>14</b>
	<b>C Accessories</b>	-	-	-	<b>15-16</b>
	<b>RA</b>	Single-Acting	Spring	18-91	<b>17</b>
	<b>RLS</b>	Single-Acting	Spring	4,5-136	<b>18</b>
	<b>RSS</b>	Single-Acting Double-Acting	Spring	9-227	<b>19-20</b>
	<b>RH</b>	Single-Acting Double-Acting	Spring Hydraulic	91-91 27-181	<b>21-22</b>
	<b>RT</b>	Single-Acting	Spring	15-91	<b>23-24</b>
	<b>RGG</b>	Single-Acting	Load	50-544	<b>25-28</b>
	<b>RDG</b>	Double-Acting	Hydraulic	50-544	<b>29-32</b>
	<b>RD</b>	Double-Acting	Hydraulic	9-454	<b>33-34</b>
	<b>R</b>	Single-Acting Double-Acting	Load Hydraulic	50-513 91-513	<b>35-36</b>
	<b>RGL</b>	Single-Acting Double-Acting	Load Hydraulic	50-544	<b>37-38</b>
	<b>RA_L R_L</b>	Single-Acting, Locking	Load	50-91 50-513	<b>39-40</b>
	<b>RGP Series</b>	Single-Acting, Locking	Load	61-513	<b>41</b>
	<b>Z-Series</b>	Various	Various	499-1497	<b>42</b>



## SELECTING THE RIGHT CYLINDER:

**Step 1:** Select the hydraulic cylinder that best suits the application.

**Step 2:** Select a hydraulic pump with adequate oil output and reservoir capacity to power cylinder.

**Step 3:** Select pump and valve option that is best suited to the cylinder and application.

## CYLINDER SIZING CONSIDERATIONS:

1. What push or pull tonnage is required per cylinder in your application?  
Power Team recommends using 80% of the rated capacity and stroke to maximize product performance and safety.
2. What is the push or pull stroke length required?
3. Does the cylinder need to push, pull or both?  
(Single-acting cylinders extend the piston under hydraulic pressure. Double-acting cylinders extend and retract the piston under pressure.)
4. Does the application require multiple cylinders?
5. Is the application stationary, or must the components be light in weight for easy portability?
6. Do you need to extend a rod or cable through the center of the cylinder for the application, as in a tensioning operation?
7. Does the application require that the cylinder fit within limited-clearance work areas?
8. Does the application require that the cylinder be "dead-ended" at the end of its work stroke?
9. Will the cylinder need to withstand off-center loads? If yes, consider using swivel load caps.
10. Does the application require that the lifted load be supported for extended periods of time?  
Locking collars are ideal for such jobs, as are cribbing blocks.
11. Is corrosion resistance required?  
Our unique "Power-Tech" surface treatment is standard on many Power Team cylinders, and optional on many of our cylinders which feature steel construction.
12. Will the application involve high cycles (over 2500 in the cylinder's lifetime)?  
Our "RD," "RH," "RP" and "C" series cylinders are ideal choices. Please refer to pages 12-13 for the capabilities of each cylinder.

### WHAT TYPE OF CYLINDER DO YOU NEED?

1. To determine a cylinder's force capacity:

Force

Cylinder Effective Area (cm<sup>2</sup>)

X

Bar from Pump

2. To determine oil

Oil Capacity (cm<sup>3</sup>)

Cylinder Effective Area (cm<sup>2</sup>)

X

Cylinder Stroke (cm)

3. To determine reservoir capacity needed for a multiple cylinder system:

Usable Oil

Oil Cap. of Cyl. (cm<sup>3</sup>)

X

Number of Cyl. in System

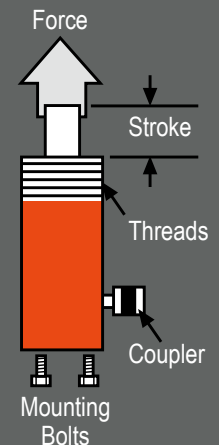

The following guidelines are for general lifting and construction applications. Hydraulic tools, pullers and presses may fall outside these recommendations. Always check to see that the pump's "usable reservoir capacity" exceeds the cylinder(s) oil capacity.

Generally Recommended	
Marginal Check Requirements	
Not Recommended for most applications	

	Pressure Stage	CYLINDER CAPACITY (Tons)														
		4.5	9	14	18	23	27	50	68	91	136	181	272	363	454	
Hand Pumps *	P12 ‡	Single	14	32	44	65	72	93								
	P55 ‡	Single	6	14	19	28	31	40	71							
	P19(L)	Low	4	8	10	15	17	21								
		High	13	30	42	59	68	86								
	P59F	Low	1.8	4.1	5.7	8	9	12	20	29						
		High	8	17	24	34	48	50	85	122						
	P59(L) ‡	Low	1.5	3.2	4.7	7	7.7	9.7	16.7	23.9						
	P157(D) ‡	High	6	14	19	28	31	40	71	101						
	P159(D) ‡	Low	0.5	1	1.3	1.9	2.2	2.8	5	7	9	13	18			
	P300(D) ‡	High	7	15	21	30	34	43	77	110	143	200	250			
P460(D) ‡	Low	0.1	0.3	0.6	0.6	0.7	0.9	1.5	2.2	2.8	4.2	5.6	8.4	11.2		
	High	3.3	7.7	9	14	17.5	22	37	55	71	105	143	213	284		
Electric/ Hydraulic Pumps †	PB10 / PE10	Low	0.5	1.2	1.6	2.2	2.6	3.2	5.5							
		High	6	13.4	18.9	27	31	39	66.2							
	PE17 ‡	Low	0.2	0.5	0.7	0.9	1.1	1.4	2.3	3.3	4.3	6.5	8.7			
		High	3.5	7.9	10.9	16	18	23	39	56.3	73	109	146			
	PE18	Low	0.4	0.8	1.2	1.6	1.8	2.3	3.9	5.7	7.3	10.8	14.6	21.9	29.2	
		High	3.3	7.5	10.3	15	17	21	37	53	69	102	136	207	276	
	PE21 ‡	Low	0.2	0.5	0.7	1.0	1.1	1.4	2.5	3.6	4.6	6.8	9.2	13.8	18.4	
		High	2.8	6.4	9	13	15	19	32	45.5	59	88	118	177	236	
	PED25	Low	0.2	0.4	0.6	0.9	1.0	1.3	2.2	3.2	4.1	6.1	8.3	12.0	15.7	19.9
		High	2.4	5.4	7.5	10.6	12.4	15.6	26.5	38.2	49.5	73.3	99.1	144.3	188.5	238.6
	PE30 ‡	Low	0.2	0.45	0.6	0.9	1	1.3	2.2	3.2	4.1	6				
		High	2	4.5	6	9	10	13	22	32	41	60				
	PE46 ‡	Low	0.1	0.3	0.4	0.5	0.6	0.7	1.3	1.8	2.4	3.5	4.7	7.2	9.6	
		High	1.3	2.9	4.1	5.9	6.8	8.6	14	22	28	42	56	84	112	
	PE55 ‡	Low	0.1	0.2	0.3	0.4	0.4	0.6	0.9	1.4	1.8	2.6	3.5	5.4	7.2	
	PE60 ‡	High	1.4	2.4	3.4	4.8	5.6	7.1	12	17.8	23	34	45	69	92	
	PQ60	Low	0.1	0.2	0.3	0.4	0.4	0.5	0.9	1.3	1.7	2.5	3.4	5.1	6.8	8.5
		High	1	2.2	3.3	4.4	5.2	6.5	11	16.2	21	31	41	63	84	105
	PQ120	Low	0.1	0.2	0.3	0.4	0.4	0.5	0.9	1.3	1.7	2.5	3.4	5.1	6.8	8.5
		High	0.5	1.1	1.6	2.2	2.6	3.2	5.5	7.7	10	15	21	30	40	50
PE400	Low	0.1	0.1	0.2	0.2	0.3	0.3	0.6	0.8	1	1.5	2.1	3	4	5	
	High	0.1	0.3	0.4	0.6	0.7	0.9	1.6	2.2	2.9	4.4	5.9	8.7	11.6	14.5	
Air/Hydraulic Pumps †	PA6 ‡	Single	10	22.4	31	44.4	51.3	65.2								
	PA9 ‡	Single	10	22.4	31	44.4	51.3	65.2								
	PA17 ‡	Low	0.2	0.5	0.7	0.9	1.1	1.4	2.3	3.3	4.3	6.5	8.7			
		High	3.5	7.9	10.9	16	18	23	39	56	73	109	146			
	PA46 ‡	Low	0.1	0.3	0.4	0.5	0.6	0.7	1.3	2	2.4	3.5	4.7	7.2	9.6	
		High	1.3	2.9	4.1	5.9	6.8	8.6	14	22	28	42	56	84	112	
PA55 ‡	Low	0.1	0.3	0.4	0.6	0.7	0.9	1.5	2.2	2.8	4.1	5.5	8.4	11.2		
	High	1.1	2.4	3.4	4.8	5.6	7.1	12	18	23	34	45	69	92		
Gas/Hydraulic Pumps †	PG30	Low	0.3	0.7	1	1.3	1.6	2	3.3	4.8	6.2	9.3	12.4	18.1		
		High	2	4.5	6.3	8.9	10.3	13	22	31.8	41.3	61.4	83	121		
	PG55 ‡	Low	0.1	0.3	0.4	0.6	0.7	0.8	1.4	2	2.6	3.9	5.2	7.6	9.9	12.5
		High	1.1	2.5	3.5	4.9	5.6	7.1	12.1	17.3	22.5	33.5	45	66	86	109
	PG120 ‡	Low	0.1	0.3	0.4	0.6	0.7	0.8	1.4	2	2.6	3.9	5.2	7.6	9.9	12.5
		High	0.5	1.0	1.5	2.0	2.4	3.0	5.1	7.3	9.5	14.2	19.1	27.8	36.3	46.0
	PG400	Low	0.1	0.1	0.2	0.2	0.3	0.3	0.6	0.8	1.0	1.5	2.0	3.0	3.8	4.9
		High	0.2	0.3	0.5	0.7	0.8	1.0	1.7	2.4	3.1	4.6	6.2	9.0	11.8	15.0

\* Hand Pumps = Number of strokes required to move piston 1".  
 † Air, Electric and Gasoline Engine/Hydraulic pumps = Number of seconds required to move piston 1".  
 ‡ Some Power Team pumps are available in special configurations not listed in this catalog.  
 Power Team can "Assemble to order" pumps with special seals, voltages, valves, relief valve settings, etc.  
 For your special requirements, please consult your local distributor or the Power Team factory.



Metric Tons (kN)*	Stroke (mm)	Retracted Height (mm)	Cylinder Movement	Order No.	Page No.
<b>1,8 (pull)</b>	127,00	233,43	SA	RP25	14
<b>4,5 (pull)</b>	139,70	301,75	SA	RP55	14

<b>4,5 (44)</b>	14,22	41,40	SA	RLS50	18
	25,40	111,25	SA	C51C	12
	82,55	165,10	SA	C53C	12
	133,35	215,90	SA	C55C	12
	133,35	266,70	SA	C55CBT	13
	184,15	273,05	SA	C57C	12
	234,95	323,85	SA	C59C	12

<b>9 (88)</b>	11,18	44,45	SA	RLS100	18
	25,40	92,20	SA	C101C	12
	38,10	88,90	SA	RSS101	20
	54,10	120,65	SA	C102C	12
	63,50	133,35	SA	RH102	21
	104,90	171,45	SA	C104C	12
	155,70	247,65	SA	C106C	12
	155,70	292,10	SA	C106CBT	13
	158,75	296,93	DA	RD106	34
	203,20	287,27	SA	RH108	21
	206,50	298,45	SA	C108C	12
	254,00	398,53	DA	RD1010	34
	257,30	349,25	SA	C1010C	12
	257,30	393,70	SA	C1010CBT	13
	308,10	400,05	SA	C1012C	12
	358,90	450,85	SA	C1014C	12

<b>11 (107)</b>	7,87	55,63	SA	RH120	21
	41,40	122,17	SA	RH121	21
	41,40	122,17	SA	RH121T	21
	76,20	184,15	SA	RH123	21

<b>14 (133)</b>	25,40	123,95	SA	C151C	12
	54,10	149,35	SA	C152C	12
	104,90	200,15	SA	C154C	12
	155,70	271,53	SA	C156C	12
	206,50	322,33	SA	C158C	12
	257,30	373,13	SA	C1510C	12
	308,10	423,93	SA	C1512C	12
	358,90	474,73	SA	C1514C	12
406,40	522,22	SA	C1516C	12	

<b>16 (156)</b>	50,80	174,75	DA	RT172	24
-----------------	-------	--------	----	-------	----

<b>18 (178)</b>	11,18	50,80	SA	RLS200	18
	44,45	95,25	SA	RSS202	20
	50,80	155,70	SA	RH202	21
	54,10	162,05	SA	RA202	17
	76,20	153,92	SA	RH203	21
	104,90	212,85	SA	RA204	17
	152,40	308,10	SA	RH206	21
	155,70	263,65	SA	RA206	17

<b>23 (223)</b>	25,40	139,70	SA	C251C	12
	50,80	165,10	SA	C252C	12
	101,60	215,90	SA	C254C	12
	158,75	273,05	SA	C256C	12
	158,75	339,85	SA	C256CBT	13
	158,75	314,45	DA	RD256	34
	209,55	323,85	SA	C258C	12
	260,35	374,65	SA	C2510C	12
	311,15	425,45	SA	C2512C	12
	358,90	476,25	SA	C2514C	12
	358,90	517,65	DA	RD2514	34
358,90	543,05	SA	C2514CBT	13	

<b>27 (267)</b>	12,70	58,67	SA	RLS300	18
	54,10	187,45	SA	RA302	17
	61,98	117,60	SA	RSS302	20
	63,50	158,75	SA	RH302	21
	63,50	214,38	DA	RT302	24
	76,20	179,32	SA	RH303	22
	104,90	238,25	SA	RA304	17
	149,35	282,70	SA	RHA306	21
	152,40	247,65	SA	RH306	21
	152,40	280,92	DA	RH306D	22
	155,70	289,05	SA	RA306	17
	209,55	325,12	SA	C308C	12
	257,30	438,15	DA	RH3010	22

<b>45 (445)</b>	16,00	66,80	SA	RLS500S	18
	60,45	127,00	SA	RSS502	20
	76,20	181,10	SA	RH503	21
	76,20	268,22	DA	RT503	24

<b>50 (489)</b>	50,80	125,48	SA	R552C	35
	50,80	162,05	SA	R552L	40
	50,80	174,75	SA	C552C	12
	50,80	199,14	DA	RDG552	30
	50,80	199,14	SA	RG552	26
	54,10	171,45	SA	RA552	17
	101,60	249,94	DA	RDG554	30
	101,60	249,94	SA	RG554	26
	104,90	222,25	SA	RA554	17
	107,95	231,90	SA	C554C	12
	152,40	227,08	SA	R556C	35
	152,40	263,65	SA	R556L	40
	152,40	300,74	DA	RDG556	30
	152,40	300,74	SA	RG556	26
	155,70	273,05	SA	RA556	17
	155,70	317,50	SA	RA556L	39
	158,75	282,70	SA	C556C	12
	158,75	329,44	DA	RD556	34
	203,20	351,54	DA	RDG558	30
	203,20	351,54	SA	RG558	26
	254,00	328,93	SA	R5510C	35
	254,00	365,25	SA	R5510L	40
	254,00	384,30	SA	RA5510	17
	254,00	402,34	DA	RDG5510	30
	254,00	402,34	SA	RG5510	26
	260,35	384,30	SA	C5510C	12
	304,80	453,14	DA	RDG5512	30
	304,80	453,14	SA	RG5512	26
	330,20	478,54	DA	RDG5513	30
	330,20	478,54	SA	RG5513	26
	333,50	503,94	DA	RD5513	34
336,55	460,50	SA	C5513C	12	
355,60	503,94	DA	RDG5514	30	
355,60	503,94	SA	RG5514	26	
460,50	657,35	DA	RD5518	34	

<b>54 (533)</b>	76,20	234,95	SA	RH603	21
	101,60	241,30	DA	RHA604D	22
	127,00	241,30	DA	RH605	21
	152,40	317,50	SA	RH606	22
	257,30	458,72	DA	RH6010	22

<b>68 (667)</b>	16,00	79,50	SA	RLS750S	18
	50,80	211,07	DA	RDG752	30
	50,80	211,07	SA	RG752	26
	101,60	261,87	DA	RDG754	30
	101,60	261,87	SA	RG754	26
	152,40	312,67	DA	RDG756	30
	152,40	312,67	SA	RG756	26
	155,70	314,45	SA	C756C	12

<b>68 (667)</b>	203,20	363,47	DA	RDG758	30
	203,20	363,47	SA	RG758	26
	254,00	414,27	DA	RDG7510	30
	254,00	414,27	SA	RG7510	26
	304,80	465,07	DA	RDG7512	30
	304,80	465,07	SA	RG7512	26
	330,20	490,47	DA	RDG7513	30
	330,20	490,47	SA	RG7513	26
	333,50	492,25	SA	C7513C	12
	355,60	515,87	DA	RDG7514	30
	355,60	515,87	SA	RG7514	26

<b>73 (712)</b>	333,50	517,65	DA	RD8013	34
-----------------	--------	--------	----	--------	----

<b>91 (889)</b>	16,00	85,85	SA	RLS1000S	18
	38,10	144,53	DA	RSS1002D	20
	38,10	165,10	SA	RH1001	22
	50,80	139,70	SA	R1002C	35
	50,80	168,66	DA	R1002D	36
	50,80	184,15	SA	R1002L	40
	50,80	219,20	SA	C1002C	12
	50,80	220,98	DA	RDG1002	30
	50,80	220,98	SA	RG1002	26
	54,10	196,85	SA	RA1002	17
	57,15	139,70	SA	RSS1002	20
	76,20	254,00	SA	RH1003	21
	101,60	271,78	DA	RDG1004	30
	101,60	271,78	SA	RG1004	26
	123,95	384,30	DA	RT1004	24
	152,40	241,30	SA	R1006C	35
	152,40	270,26	DA	R1006D	36
	152,40	285,75	SA	R1006L	40
	152,40	314,45	DA	RH1006	22
	152,40	322,58	DA	RDG1006	30
	152,40	322,58	SA	RG1006	26
	158,75	298,45	SA	RA1006	17
	158,75	339,85	SA	RA1006L	39
	168,40	336,55	SA	C1006C	12
	168,40	350,01	DA	RD1006	34
	203,20	373,38	DA	RDG1008	30
	203,20	373,38	SA	RG1008	26
	254,00	371,86	DA	R10010D	36
	254,00	387,35	SA	R10010L	40
	254,00	424,18	DA	RDG10010	30
	254,00	424,18	SA	RG10010	26
	257,30	503,17	DA	RH10010	22
	260,35	397,00	SA	RA10010	17
	260,35	428,75	SA	C10010C	12
	304,80	474,98	DA	RDG10012	30
	304,80	474,98	SA	RG10012	26
	330,20	500,38	DA	RDG10013	30
	330,20	500,38	SA	RG10013	26
	333,50	515,11	DA	RD10013	34
	355,60	525,78	DA	RDG10014	30
	355,60	525,78	SA	RG10014	26
	511,30	718,31	DA	RD10020	34

<b>136 (1335)</b>	14,22	101,60	SA	RLS1500S	18
	50,80	162,05	SA	R1502C	35
	50,80	188,98	DA	R1502D	36
	50,80	206,50	SA	R1502L	40
	50,80	238,00	DA	RDG1502	30
	50,80	238,00	SA	RG1502	26
	101,60	288,80	DA	RDG1504	30
	101,60	288,80	SA	RG1504	26
	127,00	308,10	DA	RH1505	22
	152,40	263,65	SA	R1506C	35
	152,40	290,58	DA	R1506D	36
	152,40	308,10	SA	R1506L	40
	152,40	339,60	DA	RDG1506	30

SA - Single-Acting  
 DA - Double-Acting  
 \* Kilonewtons

Metric Tons (kN)*	Stroke (mm)	Re-tracted Height (mm)	Cylinder Movement	Order No.	Page No.
<b>136 (1335)</b>	152,40	339,60	SA	RGG1506	26
	168,40	377,95	DA	RD1506	34
	203,20	349,25	DA	RH1508	22
	203,20	390,40	DA	RDG1508	30
	203,20	390,40	SA	RGG1508	26
	254,00	365,25	SA	R15010C	35
	254,00	409,70	SA	R15010L	40
	254,00	441,20	DA	RDG15010	30
	254,00	441,20	SA	RGG15010	26
	304,80	492,00	DA	RD15012	30
	304,80	492,00	SA	RGG15012	26
	330,20	517,40	DA	RDG15013	30
	330,20	517,40	SA	RGG15013	26
	333,50	543,05	DA	RD15013	34
	355,60	542,80	DA	RDG15014	30
	355,60	542,80	SA	RGG15014	26
	460,50	673,86	DA	RD15018	34

50,80	190,50	SA	R2002C	35
50,80	206,76	DA	R2002D	36
50,80	241,30	SA	R2002L	40
50,80	255,02	DA	RDG2002	30
50,80	255,02	SA	RGG2002	26
101,60	305,82	DA	RDG2004	30
101,60	305,82	SA	RGG2004	26
152,40	292,10	SA	R2006C	35
152,40	308,36	DA	R2006D	36
152,40	342,90	SA	R2006L	40
152,40	356,62	DA	RDG2006	30
152,40	356,62	SA	RGG2006	26
168,40	406,40	DA	RD2006	34
203,20	393,70	SA	R2008L	40
203,20	407,92	DA	RH2008	22
203,20	407,42	DA	RDG2008	30
203,20	407,42	SA	RGG2008	26
254,00	409,96	DA	R20010D	36
254,00	458,22	DA	RDG20010	30
254,00	458,22	SA	RGG20010	26
330,20	509,02	DA	RDG20013	30
330,20	509,02	SA	RGG20013	26
333,50	571,50	DA	RD20013	34
355,60	559,82	DA	RDG20014	30
355,60	559,82	SA	RGG20014	26
460,50	723,90	DA	RD20018	34

50,80	261,62	DA	RDG2502	32
50,80	261,62	SA	RGG2502	28
76,20	290,58	SA	RSS2503	20
101,60	312,42	DA	RDG2504	32
101,60	312,42	SA	RGG2504	28
152,40	363,22	DA	RDG2506	32
152,40	363,22	SA	RGG2506	28
203,20	414,02	DA	RDG2508	32
203,20	414,02	SA	RGG2508	28
254,00	464,82	DA	RDG25010	32
254,00	464,82	SA	RGG25010	28
304,80	515,62	DA	RDG25012	32
304,80	515,62	SA	RGG25012	28
330,20	541,02	DA	RDG25013	32
330,20	541,02	SA	RGG25013	28
355,60	566,42	DA	RDG25014	32
355,60	566,42	SA	RGG25014	28

<b>254 (2491)</b>	50,80	190,50	SA	R2802C	35
	50,80	233,68	DA	R2802D	36
	50,80	247,65	SA	R2802L	40
	152,40	292,10	SA	R2806C	35
	152,40	335,28	DA	R2806D	36
	152,40	349,25	SA	R2806L	40
	254,00	436,88	DA	R28010D	36
	254,00	450,85	SA	R28010L	40

<b>272 (2667)</b>	50,80	272,80	DA	RDG3002	32
	50,80	272,80	SA	RGG3002	28
	101,60	323,60	DA	RDG3004	32
	101,60	323,60	SA	RGG3004	28
	152,40	374,40	DA	RDG3006	32
	152,40	374,40	SA	RGG3006	28
	152,40	438,91	DA	RD3006	34
	203,20	425,20	DA	RDG3008	32
	203,20	425,20	SA	RGG3008	28
	254,00	476,00	DA	RDG30010	32
	254,00	476,00	SA	RGG30010	28
	304,80	526,80	DA	RDG30012	32
	304,80	526,80	SA	RGG30012	28
	330,20	552,20	DA	RDG30013	32

<b>322,1 (3158)</b>	50,80	231,90	SA	R3552C	35
	50,80	289,05	DA	R3552D	36
	50,80	292,10	SA	R3552L	40
	152,40	333,50	SA	R3556C	35
	152,40	390,65	DA	R3556D	36
	152,40	393,70	SA	R3556L	40
254,00	435,10	SA	R35510C	35	

<b>363 (3559)</b>	50,80	306,58	DA	RDG4002	32
	50,80	306,58	SA	RGG4002	28
	101,60	357,38	DA	RDG4004	32
	101,60	357,38	SA	RGG4004	28
	152,40	408,18	DA	RDG4006	32
	152,40	408,18	SA	RGG4006	28
	152,40	489,71	DA	RD4006	34
	203,20	458,98	DA	RDG4008	32
	203,20	458,98	SA	RGG4008	28
	254,00	509,78	DA	RDG40010	32
	254,00	509,78	SA	RGG40010	28
	304,80	560,58	DA	RDG40012	32
	304,80	560,58	SA	RGG40012	28
	330,20	585,98	DA	RDG40013	32

<b>390 (3826)</b>	50,80	263,65	SA	R4302C	35
	50,80	312,67	DA	R4302D	36
	50,80	333,50	SA	R4302L	40
	152,40	365,25	SA	R4306C	35
	152,40	414,27	DA	R4306D	36
	152,40	435,10	SA	R4306L	40
	254,00	515,87	DA	R43010D	36
	254,00	536,70	SA	R43010L	40

<b>454 (4448)</b>	50,80	311,91	DA	RDG5002	32
	50,80	311,91	SA	RGG5002	28
	101,60	311,91	DA	RDG5004	32
	101,60	362,71	SA	RGG5004	28
	152,40	413,51	DA	RDG5006	32
	152,40	413,51	SA	RGG5006	28
	152,40	522,22	DA	RD5006	34
	203,20	464,31	DA	RDG5008	32
	203,20	464,31	SA	RGG5008	28
	254,00	515,11	DA	RDG50010	32
	254,00	515,11	SA	RGG50010	28
	304,80	565,91	DA	RDG50012	32
	304,80	565,91	SA	RGG50012	28
	330,20	591,31	DA	RDG50013	32
	330,20	591,31	SA	RGG50013	28
	330,20	700,02	DA	RD50013	34
	355,60	616,71	DA	RDG50014	32
	355,60	616,71	SA	RGG50014	28

<b>512,6 (5027)</b>	50,80	292,10	SA	R5652C	35
	50,80	345,19	DA	R5652D	36
	50,80	371,60	SA	R5652L	40
	152,40	393,70	SA	R5656C	35
	152,40	446,79	DA	R5656D	36
	152,40	473,20	SA	R5656L	40
	254,00	495,30	SA	R56510C	35
	254,00	548,39	DA	R56510D	36
	254,00	574,80	SA	R56510L	40

<b>544,1 (5336)</b>	50,80	324,10	DA	RDG6002	32
	50,80	324,10	SA	RGG6002	28
	101,60	374,90	DA	RDG6004	32
	101,60	374,90	SA	RGG6004	28
	152,40	425,70	DA	RDG6006	32
	152,40	425,70	SA	RGG6006	28
	203,20	476,50	DA	RDG6008	32
	203,20	476,50	SA	RGG6008	28
	254,00	527,30	DA	RDG60010	32
	254,00	527,30	SA	RGG60010	28
	304,80	578,10	DA	RDG60012	32
	304,80	578,10	SA	RGG60012	28
	330,20	603,50	DA	RDG60013	32
	330,20	603,50	SA	RGG60013	28
355,60	628,90	DA	RDG60014	32	
355,60	628,90	SA	RGG60014	28	

<b>671 - 1107 (6583-10854)</b>	50,8	—	SA	RC_C	37
	152,4	—	SA	RC_C	37
	254,0	—	SA	RC_C	37
	50,4	—	DA	RC_D	38
	152,4	—	DA	RC_D	38
	254,0	—	DA	RC_D	38
50,4	—	SA	RC_L	42	
152,4	—	SA	RC_L	42	
254,0	—	SA	RC_L	42	

SA - Single-Acting  
DA - Double-Acting  
\* Kilonewtons

Model Shown:  
**Various Types of C-Series**



**Features**

**RUGGED, HIGH QUALITY CYLINDER USED FOR LIFTING AND PRESSING.**

- Aluminum bronze bearing reduces wear caused by off-center loads.
- Maximum sized springs speed piston return and increase spring life.
- Collar threads are standard on all C-Series models, simplifying fixturing applications.
- Removeable rubber boots protects collar threads during transport and storage.
- Solid steel cylinder body for durability.
- Chrome plated piston rod resists wear and corrosion.
- Wide range of accessories available that mount onto the piston rod, collar, or base.
- Base mounting holes standard on 4,5 through 50 ton cylinders and optional on 68 and 91 ton cylinders.
- A 3/8" NPTF female half coupler is standard.
- Complies with ANSI / ASME B30.1 safety standards.

▶ C10010C used in this pulling application.



**Best Practice for Cylinder Selection**



Power Team recommends using 80% of the rated capacity and stroke to maximize product performance and safety.



**Optional Cylinders Lifting Handle**



**Order Number:** 420655OR9  
Lifting handle for "C" series, 25 ton cylinders

▶ **Technical Dimensions, Base Mounting Holes**

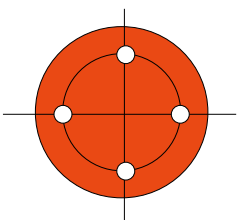

Cylinder Tonnage	4,5	9	14	23	27	50	68*	91*
# of Holes	2†	2†	2†	2†	2†	2†	4	4
Thread Size**	1/4 - 20	5/16 - 18	3/8 - 16	1/2 - 13	1/2-13	1/2 - 13	3/4 - 10	1 - 8
Thread Depth (mm)	9,50	12,70	12,70	19,10	19,10	19,10	25,40	25,40
Bolt Circle Diameter (mm)	25,40	39,70	47,60	58,70	73,66	95,30	114,30	120,70

\* Consult Factory (45° from coupler)  
† 90° from coupler  
\*\*Threads are UN

**Technical Dimensions**

Cylinder Load Caps furnished with "C" Series Cylinders:

4,5 ton cylinders	No. 201375
9 ton cylinders	No. 201362
14 ton cylinders	No. 201362
23 ton cylinders	No. 201412
27 ton cylinders	No. 201412
50 ton cylinders	No. 36161
68 ton cylinders	No. 36161
91 ton cylinders	No. 36161

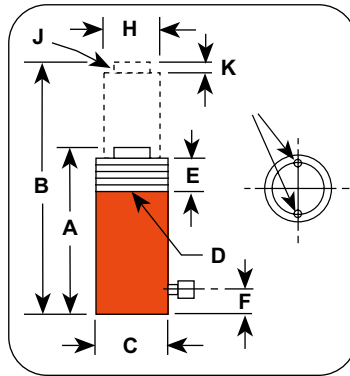

**C10010C used in this lift application.**



**Ordering Information**

Cyl. Cap. Metric Tons (kN)*	Stroke (mm)	Order No.	Oil Cap. (cm³)	A		C		D		E		F		H		J		K		Bore Dia. (mm)	Cylinder Effective Area (cm²)	Metric Tons at 700 (bar)	Prod. Wt. (kg)
				Re-tracted Height (mm)	Ex-tended Height (mm)	Outside Dia. (mm)	Collar Thread* (in.)	Piston Collar Thread Length (mm)	Base to Port (mm)	Piston Rod Dia. (mm)	Piston Rod Int. Thread and Depth* (in.)	Rod Pro-trusion (mm)											
4,5 (49)	25,4	C51C	18	110,3	138,1	38,1	1 1/2-16	28,6	19,1	25,4	3/4-16 x 15,9	6,4	28,6	6,4	4,5	1,0							
	82,6	C53C	52	165,1	247,7	38,1	1 1/2-16	28,6	19,1	25,4	3/4-16 x 15,9	6,4	28,6	6,4	4,5	1,5							
	133,4	C55C	85	215,9	349,3	38,1	1 1/2-16	28,6	19,1	25,4	3/4-16 x 15,9	6,4	28,6	6,4	4,5	1,8							
	184,2	C57C	118	273,1	457,2	38,1	1 1/2-16	28,6	19,1	25,4	3/4-16 x 15,9	6,4	28,6	6,4	4,5	2,3							
	235,0	C59C	151	323,9	558,8	38,1	1 1/2-16	28,6	19,1	25,4	3/4-16 x 15,9	6,4	28,6	6,4	4,5	2,6							
9 (98)	25,4	C101C	36	92,1	117,5	57,2	2 1/4-14	28,6	19,1	38,1	1-8 x 19,1	6,4	42,8	14,4	10,2	1,8							
	54,0	C102C	79	120,7	172,8	57,2	2 1/4-14	28,6	19,1	38,1	1-8 x 19,1	6,4	42,8	14,4	10,2	2,3							
	104,8	C104C	151	171,5	276,2	57,2	2 1/4-14	28,6	19,1	38,1	1-8 x 19,1	6,4	42,8	14,4	10,2	3,0							
	155,6	C106C	225	247,7	403,2	57,2	2 1/4-14	28,6	19,1	38,1	1-8 x 19,1	6,4	42,8	14,4	10,2	4,3							
	206,4	C108C	326	298,5	504,8	57,2	2 1/4-14	28,6	19,1	38,1	1-8 x 19,1	6,4	42,8	14,4	10,2	5,0							
	257,2	C1010C	370	349,3	606,4	57,2	2 1/4-14	28,6	19,1	38,1	1-8 x 19,1	6,4	42,8	14,4	10,2	5,9							
	308,0	C1012C	444	400,1	708,0	57,2	2 1/4-14	28,6	19,1	38,1	1-8 x 19,1	6,4	42,8	14,4	10,2	6,6							
	358,8	C1014C	518	450,9	809,6	57,2	2 1/4-14	28,6	19,1	38,1	1-8 x 19,1	6,4	42,8	14,4	10,2	7,3							
406,4	C1016C	592	520,7	927,1	57,2	2 1/4-14	28,6	19,1	38,1	1-8 x 19,1	6,4	42,8	14,4	10,2	8,4								
14 (147)	25,4	C151C	51	123,8	149,2	69,9	2 3/4-16	28,6	19,1	44,5	1-8 x 19,1	6,4	50,8	20,3	14,2	3,4							
	54,0	C152C	110	149,2	203,2	69,9	2 3/4-16	28,6	19,1	44,5	1-8 x 19,1	6,4	50,8	20,3	14,2	4,0							
	104,8	C154C	211	200,0	304,8	69,9	2 3/4-16	28,6	19,1	44,5	1-8 x 19,1	6,4	50,8	20,3	14,2	5,2							
	155,6	C156C	315	271,4	427,0	69,9	2 3/4-16	28,6	19,1	44,5	1-8 x 19,1	6,4	50,8	20,3	14,2	6,9							
	206,4	C158C	418	322,2	528,6	69,9	2 3/4-16	28,6	19,1	44,5	1-8 x 19,1	6,4	50,8	20,3	14,2	8,1							
	257,2	C1510C	521	373,0	630,2	69,9	2 3/4-16	28,6	19,1	44,5	1-8 x 19,1	6,4	50,8	20,3	14,2	9,4							
	308,0	C1512C	625	423,8	731,8	69,9	2 3/4-16	28,6	19,1	44,5	1-8 x 19,1	6,4	50,8	20,3	14,2	10,5							
	358,8	C1514C	728	474,6	833,4	69,9	2 3/4-16	28,6	19,1	44,5	1-8 x 19,1	6,4	50,8	20,3	14,2	11,8							
406,4	C1516C	824	522,3	928,7	69,9	2 3/4-16	28,6	19,1	44,5	1-8 x 19,1	6,4	50,8	20,3	14,2	12,8								
23 (245)	25,4	C251C	84	139,7	165,1	85,7	3 5/16-12	49,2	25,4	57,2	1 1/2-16 x 25,4	9,5	65,1	33,2	23,4	5,4							
	50,8	C252C	169	165,1	215,3	85,7	3 5/16-12	49,2	25,4	57,2	1 1/2-16 x 25,4	9,5	65,1	33,2	23,4	6,3							
	101,6	C254C	338	215,9	317,5	85,7	3 5/16-12	49,2	25,4	57,2	1 1/2-16 x 25,4	9,5	65,1	33,2	23,4	8,0							
	158,8	C256C	528	273,1	431,8	85,7	3 5/16-12	49,2	25,4	57,2	1 1/2-16 x 25,4	9,5	65,1	33,2	23,4	9,8							
	209,6	C258C	697	323,9	533,4	85,7	3 5/16-12	49,2	25,4	57,2	1 1/2-16 x 25,4	9,5	65,1	33,2	23,4	11,6							
	260,4	C2510C	865	374,4	635,0	85,7	3 5/16-12	49,2	25,4	57,2	1 1/2-16 x 25,4	9,5	65,1	33,2	23,4	13,3							
	311,2	C2512C	1036	425,5	736,0	85,7	3 5/16-12	49,2	25,4	57,2	1 1/2-16 x 25,4	9,5	65,1	33,2	23,4	15,0							
362,0	C2514C	1205	476,3	838,2	85,7	3 5/16-12	49,2	25,4	57,2	1 1/2-16 x 25,4	9,5	65,1	33,2	23,4	16,7								
27 (294)	209,6	C308C	88	325,1	534,7	101,6	4-12	50,8	25,4	63,5	1 1/2-16 x 22,4	9,7	72,9	41,6	29,2	16,2							
50 (539)	50,8	C552C	362	174,6	225,4	127,0	5-12	55,6	34,9	79,4	None	3,2	95,3	71,2	50,1	14,7							
	108,0	C554C	769	231,8	339,7	127,0	5-12	55,6	34,9	79,4	None	3,2	95,3	71,2	50,1	18,7							
	158,8	C556C	1131	282,6	441,3	127,0	5-12	55,6	34,9	79,4	None	3,2	95,3	71,2	50,1	23,1							
	260,4	C5510C	1853	384,2	644,5	127,0	5-12	55,6	34,9	79,4	None	3,2	95,3	71,2	50,1	30,4							
	336,6	C5513C	2398	460,4	796,9	127,0	5-12	55,6	34,9	79,4	None	3,2	95,3	71,2	50,1	35,3							
68 (735)	155,6	C756C	1596	314,3	469,9	146,1	5 3/4-12	44,5	31,8	95,3	None	3,2	114,3	102,6	72,1	33,3							
	333,4	C7513C	3421	492,1	825,5	146,1	5 3/4-12	44,5	31,8	95,3	None	3,2	114,3	102,6	72,1	49,6							
91 (981)	50,8	C1002C	675	219,1	269,9	158,8	6 1/4-12	57,2	41,3	104,8	None	3,2	130,2	133,0	93,6	28,6							
	168,3	C1006C	2245	336,6	504,8	158,8	6 1/4-12	57,2	41,3	104,8	None	3,2	130,2	133,0	93,6	41,3							
	260,4	C10010C	3467	428,6	689,0	158,8	6 1/4-12	57,2	41,3	104,8	None	3,2	130,2	133,0	93,6	51,3							

\*UN Threads

Model Shown:  
**C55CBT, C2514CBT**



**Features**

**THREADED PISTON ROD END AND BASE THREADS ACCOMMODATE ACCESSORIES AND ADAPTERS.**

- Threaded cylinder collars, piston rod ends, and internal base threads simplify mounting.
- A 9796 3/8" NPTF female half coupler is standard with each cylinder. Oil port threads are 3/8" NPTF.
- Removable threaded rod cap.
- Factory accessories do not de-rate tonnage.
- Complies with ANSI / ASME B30.1 safety Standards.



**Versatility and fixturing capabilities**

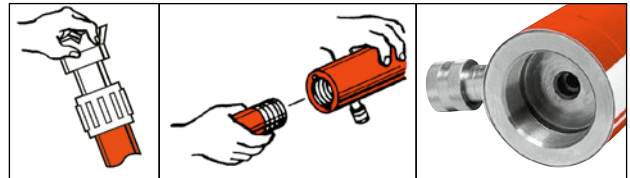

**Technical Dimensions**

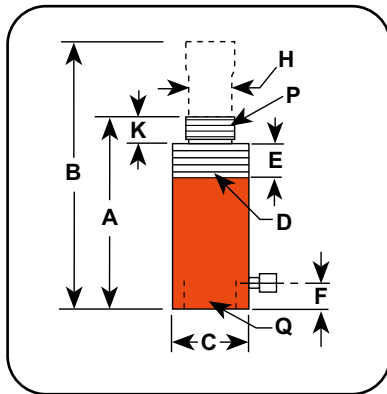

**Analog Gauges**



Improve your system visibility and safety by adding an inline hydraulic gauge to your circuit.

- 9040E (63,5 mm)
- 9052E (100 mm)

**Ordering Information**

Cyl. Cap.	Stroke	Order No.	Oil Cap.	A	B	C	D	E	F	H	K	P	Q	Bore Dia.	Cylinder Effective Area	Metric Tons at 700	Prod. Wt.
				Re-tracted Height	Ex-tended Height	Outside Dia.	Collar Thread*	Collar Thread Length	Base to Port	Piston Rod Dia.	Piston Rod Protru-sion	Piston Rod Thread (NPT)	Internal Base Thread (NPSM)				
Metric Tons (kN)*	(mm)		(cm <sup>3</sup> )	(mm)	(mm)	(mm)	(mm)	(mm)	(mm)	(mm)	(mm)	(in.)	(in.)	(mm)	(cm <sup>2</sup> )	(bar)	(kg)
4,5 (49)	133,4	C55CBT	85	266,7	400,1	38,1	1 1/2-16	28,6	47,6	25,4	28,6	3/4-14	3/4-14	28,6	6,4	4,5	2,0
9 (98)	155,6	C106CBT	228	292,1	447,7	57,2	2 1/4-14	28,6	42,9	38,1	27,0	1 1/4-11,5	1 1/4-11,5	42,9	14,4	10,2	4,7
	257,2	C1010CBT	375	393,7	650,9	57,2	2 1/4-14	28,6	42,9	38,1	27,0	1 1/4-11,5	1 1/4-11,5	42,9	14,4	10,2	6,3
23 (245)	158,8	C256CBT	528	339,7	498,5	85,7	3 5/16-12	49,2	47,6	57,2	47,6	2-11,5	2-11,5	65,1	33,3	23,4	11,1
	362,0	C2514CBT	1205	542,9	904,9	85,7	3 5/16-12	49,2	47,6	57,2	47,6	2-11,5	2-11,5	65,1	33,3	23,4	18,2

\*UN Threads

Model Shown:  
**RP25, RP55**



**Features**

**DESIGNED FOR PULLING AND TENSIONING APPLICATIONS.**

- Heavy-duty compression spring provides long cycle life and rapid extension of piston.
- Spring automatically extends piston rod when pump pressure is released.
- Complies with ANSI / ASME B30.1 safety standards.

**Technical Dimensions**

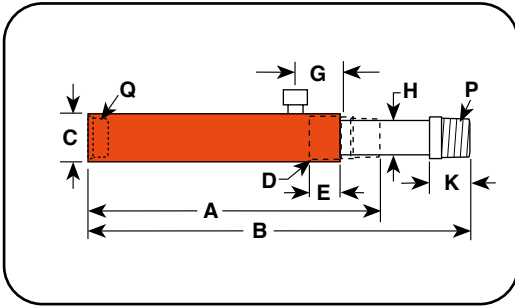

**Clevis Ordering Information**

Use with Cyl. No.	Order No.	A (mm)	B (mm)	C (mm)	D (mm)	E (mm)	F (mm)
RP25	421057*	130,30	109,47	33,27	50,80	19,05	25,40
RP55	421056**	152,40	127,00	38,10	63,50	22,35	31,75

\* For base mounting, extension rod 351106 is required.  
\*\* For base mounting, extension rod 351075 is required.

**Learn More - About Hydraulic Safety Insight**

Looking for great safety suggestions? Visit our Resource Section to get a better understanding of hydraulic and mechanical safety insights on what to look for when working around hydraulics.

**Ordering Information**

Cyl. Cap. Metric Tons (kN)*	Stroke (mm)	Order No.	Oil Cap. (cm <sup>3</sup> )	A	B	C	D	E	G	H	K	P	Q	Bore Dia. (mm)	Cylinder Effective Area (cm <sup>2</sup> )	Metric Tons at 700 (bar)	Prod. Wt. (kg)
				Re-tracted Height (mm)	Ex-tended Height (mm)	Outside Dia. (mm)	Collar Thread* (in.)	Collar Thread Length (mm)	Cyl. Top to Port (mm)	Piston Rod Dia. (mm)	Piston Rod Protru-sion (mm)	Piston Rod Thread (NPT) (in.)	Internal Base Thread (NPSM) (in.)				
2 (20)	127,0	RP25	45	242,9	379,9	44,5	1 1/2 - 16	25,4	42,9	19,1	25,4	3/4 - 14	3/4 - 14	28,6	3,5	2,5	1,8
4,5 (49)	139,7	RP55	102	301,6	441,3	57,2	2 1/4 - 14	25,4	42,9	30,2	34,9	1 1/4 - 11 1/2	1 1/4 - 11 1/2	42,9	7,3	5,1	5,0

\*UN Threads

► Support Base

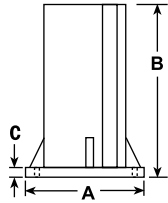

Cylinder Tons	Part No.	A (mm)	B (mm)	C (in.)
9	420062	177,8	127,8	7/16
23	420063	127,0	127,0	7/16

► Swivel Cap

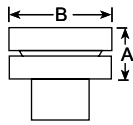

Cylinder Tons	Part No.	A (mm)	B (mm)
9 or 14	350144	22,4	36,5
23	350145	28,7	54,0
50 or 68	350376	31,8	71,4
91	351574	48,5	85,7

► Threaded Connector

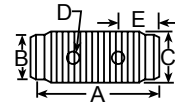
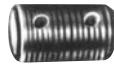

Cylinder Tons	Part No.	A (mm)	B (mm)	C (in.)	D (mm)	E (mm)
4,5	25748	44,5	22,4 Dia,	3/4 - 14 NPSM	4,8 Dia,	12,7
9	25664	41,4	36,6 Dia,	1 1/4 - 11 1/2 NPSM	7,9 Dia,	14,2
23	25654	57,2	57,2 Dia,	2 - 11 1/2 NPSM	9,7 Dia,	16,0

► Piston Clevis

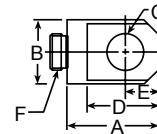

Cylinder Tons	Part No.	A (mm)	B (mm)	C (mm)	D (mm)	E (mm)	F (in.)
4,5	420095	44,5	28,7	16,0	36,6	16,0	3/4 - 16
9 or 14*	350094	65,0	42,9	22,4	58,7	25,4	1 - 8
23**	420059	74,7	57,2	31,8	68,3	31,8	1 1/2 - 16

\* Can be used with RD106, RD1010 Cylinder.

\*\* RD256 & RD2514

\*\*\*UN Thread

► Threaded & Plain Adapters

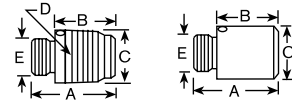

Cylinder Tons	Part No.	A (mm)	B (mm)	C (mm)	D (in.)	E (in.)
4,5	202178 (threaded)	41,4	28,7	26,9 Dia,	3/4 - 14 NPT	3/4 - 16 UNF-2A
9 or 14*	202179 (threaded)	46,0	26,9	41,4 Dia,	1 1/4 - 11 1/2 NPT	1 - 8 UNC-2A
23	202180 (threaded)	69,9	47,8	60,5 Dia,	2 - 11 1/2 NPT	1 1/2 - 16 UN-2A
9 or 14	350724 (plain)	50,8	31,8	37,6 Dia,	—	1 - 8 UNC-2A
23	350723 (plain)	54,1	31,8	57,2 Dia,	—	1 1/2 - 16 UN-2A

► Cylinder Mounting Plate

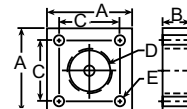

Cylinder Tons	Part No.	A (mm)	B (mm)	C (mm)	D (in.)	E (mm)
4,5	350099	76,2	25,4	54,1	1 1/2 - 16 UN-2B	8,6
9	350100	88,9	25,4	66,8	2 1/4 - 14 UNS-2B	8,6
14	350184	88,9	25,4	66,8	2 3/4 - 16 UN-2B	8,6
23	420064	127,0	50,8	100,8	3 5/16 - 12 UN-2B	16,8

► Cylinder Flat Base

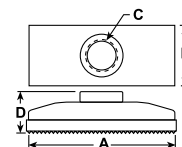

Cylinder Tons	Part No.	A (mm)	B (mm)	C (in.)	D (mm)
4,5	25750	114,3	63,5	3/4 - 14 NPSM	34,0

\* Items require threaded adapter when used with "C" series cylinders.

**▶ Extension Rod**

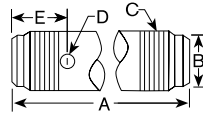

Cylinder Tons	Part No.	A	B	C	D	E
		(mm)	(mm)	(in.)	(mm)	(mm)
4,5	350895	127,0	22,4 Dia.	3/4 - 14 NPT	8,4 Dia.	50,8
4,5	38908	254,0	22,4 Dia.	3/4 - 14 NPT	8,4 Dia.	50,8
4,5	350896	457,2	22,4 Dia.	3/4 - 14 NPT	8,4 Dia.	50,8
9	350897	127,0	36,6 Dia.	1 1/4 - 11 1/2 NPT	8,4 Dia.	50,8
9	38909	254,0	36,6 Dia.	1 1/4 - 11 1/2 NPT	8,4 Dia.	50,8
9	350898	457,2	36,6 Dia.	1 1/4 - 11 1/2 NPT	8,4 Dia.	50,8

**▶ 90° "V" Base**

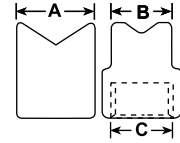
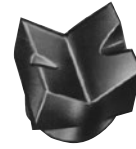

Cylinder Tons	Part No.	A	B	C
		(mm)	(mm)	(in.)
4,5	25388*	35,1	26,9	3/4 - 14 NPSM
9	25395*	54,1	54,1	1 1/4 - 14 NPSM

\* Items require threaded adapter when used with "C" series cylinders. They may be used on threaded "CBT" cylinders without the use of an adapter.

**▶ Cylinder Base Attachment**

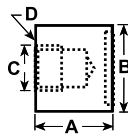

Cylinder Tons	Part No.	A	B	C	D
		(mm)	(mm)	(in.)	(mm / in.)
4,5	208380	41,4	44,5 Dia.	3/4 - 14 NPSM	7,1 Dia, (2) 1/4 - 20 UNC x 3/4 Lg, Socket Head Cap Screws
9	208381	47,8	63,5 Dia.	1 1/4 - 11 1/2 NPSM	8,6 Dia, (2) 5/16 - 18 UNC x 3/4 Lg, Socket Head Cap Screws
23	208382	60,5	85,9 Dia.	2 - 11 1/2 NPSM	13,5 Dia, (2) 1/2 - 13 UNC x 1 Lg, Socket Head Cap Screws

**▶ Plunger Base**

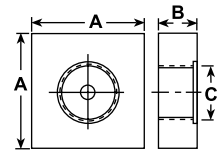
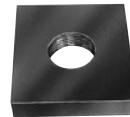

Cylinder Tons	Part No.	A	B	C
		(mm)	(mm)	(in.)
23	25652	152,4	31,8	2 - 11 1/2 NPSM

**▶ Plain & Serrated Saddles**

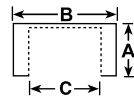
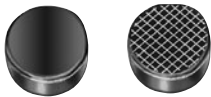

Cylinder Tons	Part No.	A	B	C
		(mm)	(mm)	(in.)
4,5	25746* (serrated)	28,7	33,3 Dia.	3/4 - 14 NPSM
9 or 14*	31772* (serrated)	28,7	50,8 Dia.	1 1/4 - 11 1/2 NPSM
23	31776* (serrated)	33,3	76,2 Dia.	2 - 11 1/2 NPSM
4,5	351575* (plain)	28,7	33,3 Dia.	3/4 - 14 NPSM
9	24016* (plain)	28,7	50,8 Dia.	1 1/4 - 11 1/2 NPSM
23	351576* (plain)	33,3	76,2 Dia.	2 - 11 1/2 NPSM

\* Items require threaded adapter when used with "C" series cylinders. They may be used on threaded "CBT" cylinders without the use of an adapter.

**▶ Body Clevis †**

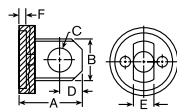

Cylinder Tons	Part No.	A	B	C	D	E	F
		(mm)	(mm)	(mm)	(mm)	(mm)	(mm)
4,5	350096	52,3	28,7	16,0	16,0	14,2	6,4
9	350097	76,2	42,9	22,4	25,4	25,4	6,4
14	350098	77,7	42,9	22,4	25,4	25,4	6,4
23	420061	90,4	57,2	31,8	31,8	31,8	6,4

† Mounting screws are included.

Model Shown:

**RA552, RA1006**



**Features**

**LIGHTWEIGHT DESIGN, EASY TO TRANSPORT AND POSITION.**

- Hard coated aluminum piston rod and cylinder bore resist wear and corrosion.
- Grooved piston top helps keep the load from sliding on top of piston.
- Aluminum body resists sparking in explosive environments.
- Complies with ANSI / ASME B30.1 safety standards.



**Optional Cylinders Bases**

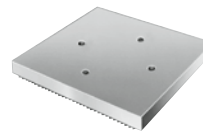

Aluminum Cylinder Base – For use when an enlarged cylinder base is needed or advantageous. Attaches to bottom of RA556, RA556L and RA5510 with four 3/8"–16 screws (included). Serrated base for extra stability.

**Order No: 208406** – Aluminum cylinder base, 317cm<sup>2</sup>.

**Technical Dimensions**

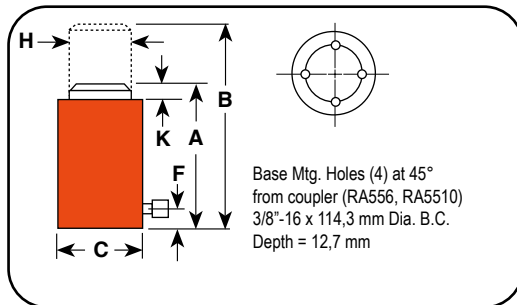

**Optional Cylinders Lifting Handles**



**Order Number: 420496BK2**  
Lifting handle for RA552, RA554 cylinders

**Order Number: 420498BK2**  
Lifting handle for RA1002, RA10010 cylinders

**Ordering Information**

Cyl. Cap. Metric Tons (kN)*	Stroke (mm)	Order No.	Oil Cap. (cm <sup>3</sup> )	A	B	C	F	H	K	Bore Dia. (mm)	Cylinder Effective Area (cm <sup>2</sup> )	Metric Tons at 700 (bar)	Prod. Wt. (kg)
				Retracted Height (mm)	Extended Height (mm)	Outside Dia. (mm)	Base to Port (mm)	Piston Rod Dia. (mm)	Piston Rod Protrusion (mm)				
18 (191)	54,0	RA202	154	161,9	215,9	95,3	31,8	50,8	7,9	60,3	28,6	20,1	3,5
	104,8	RA204	300	212,7	317,5	95,3	31,8	50,8	7,9	60,3	28,6	20,1	4,2
	155,6	RA206	445	263,5	419,1	95,3	31,8	50,8	7,9	60,3	28,6	20,1	5,1
27 (294)	54,0	RA302	226	187,3	241,3	108,0	31,8	63,5	9,5	73,0	41,9	29,4	5,0
	104,8	RA304	439	238,1	342,9	108,0	31,8	63,5	9,5	73,0	41,9	29,4	5,9
	155,6	RA306	652	288,9	444,5	108,0	31,8	63,5	9,5	73,0	41,9	29,4	6,8
50 (539)	54,0	RA552	386	171,5	225,4	133,4	34,9	79,4	6,4	95,3	71,2	50,1	7,3
	104,8	RA554	746	222,3	327,0	133,4	34,9	79,4	6,4	95,3	71,2	50,1	8,9
	155,6	RA556*	1109	273,1	428,6	133,4	34,9	79,4	6,4	95,3	71,2	50,1	10,9
	254,0	RA5510*	1811	384,2	638,2	133,4	34,9	79,4	6,4	95,3	71,2	50,1	14,4
91 (981)	54,0	RA1002	718	196,9	250,8	187,3	30,2	104,8	3,2	130,2	133,0	93,5	15,1
	158,8	RA1006*	2116	298,5	457,2	187,3	30,2	104,8	3,2	130,2	133,0	93,5	22,6
	260,4	RA10010*	3463	396,9	655,3	187,3	30,2	104,8	5,6	130,2	133,0	93,5	30,4

\* Equipped with carrying handles.

Model Shown:  
**RLS100**



**Features**

**IDEAL LOW CLEARANCE OR TIGHT CONSTRAINT APPLICATIONS REQUIRING HIGH FORCES.**

- Low height starting at 41,3 to 101,6 mm.
- Cylinder body, piston and gland nut are “Power-Tech” treated for corrosion and abrasion resistance.
- Standard domed piston rod (4,5-27 tons) or swivel cap (45-136 tons) minimize effects of off-center loading.
- Unique heavy-duty spring provides fast piston return on all cylinders.
- Couplers on all cylinders except RLS50 are angled upwards.
- Complies with ANSI / ASME B30.1 safety standards.

▶ RLS200 used in this lifting application.

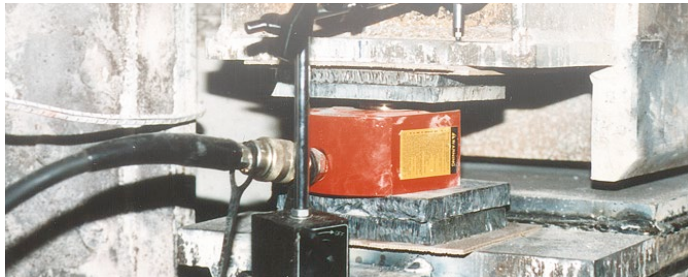

**RLS1000S (with swivel load cap)**



RLS Series ending with an “S” suffix denotes models equipped with a swivel load cap.

**Technical Dimensions**

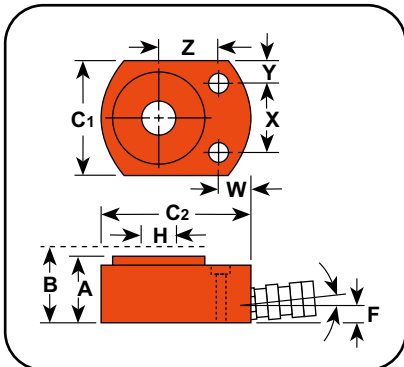

**Mounting holes for “RLS” cylinders**

Order Number	C' Bore (mm)	Depth (mm)	"Thru Hole " (mm)
RLS50	8,6	6,4	5,6
RLS100	10,7	8,7	7,1
RLS200	15,5	10,4	10,4
RLS300	15,5	11,2	10,4
RLS500S	17,8	12,7	11,9
RLS750S	20,3	14,2	13,5
RLS1000S	20,3	14,2	13,5
RLS1500S	20,3	14,2	13,5

**Ordering Information**

Cyl. Cap. Metric Tons (kN)*	Stroke (mm)	Order No.	Oil Cap. (cm³)	A	B	C1 C2		F	H	Mounting Hole Location				Bore Dia. (mm)	Cylinder Effective Area (cm²)	Metric Tons at 700 (bar)	Prod. Wt. (kg)
				Retracted Height (mm)	Extended Height (mm)	Outside Dia. (mm)	Outside Dia. (mm)	Base to Port (mm)	Piston Rod Dia. (mm)	(mm)	(mm)	(mm)	(mm)				
4,5 (49)	14,3	RLS50	10	41,3	55,6	41,3	65,1	19,1	15,9	19,1	28,6	6,4	25,4	28,6	6,4	4,5	1,0
9 (99)	11,1	RLS100	17	44,5	55,6	55,6	82,6	15,9	19,1	17,5	36,5	9,5	33,3	42,9	14,4	10,1	1,5
18 (191)	11,1	RLS200	33	50,8	61,9	76,2	101,6	16,7	28,6	18,3	49,2	13,5	39,7	60,3	28,6	20,1	2,5
27 (294)	12,7	RLS300	53	58,7	71,4	95,3	114,3	18,3	34,9	20,6	52,4	21,4	44,5	73,0	41,9	29,5	3,9
45 (490)	15,9	RLS500S	99	66,7	82,6	114,3	139,7	21,4	44,5	23,8	66,7	23,8	54,0	88,9	62,1	43,6	6,3
68 (735)	15,9	RLS750S	163	79,4	95,3	140,5	165,1	25,4	54,0	23,8	76,2	32,1	65,9	114,3	102,6	72,2	10,6
91 (981)	15,9	RLS1000S	202	85,7	101,6	152,4	177,8	25,4	63,5	20,6	76,2	38,1	71,	127,0	126,6	89,1	13,6
136 (1471)	14,3	RLS1500S	282	101,6	115,9	190,5	215,9	33,3	76,5	33,3	117,5	36,5	79,4	158,8	197,9	139,2	23,6

Model Shown:

**RSS2503, RSS302**



**Features**

**IDEAL FOR CONFINED AREAS WITH 88,9 TO 290,5 MM CLEARANCE.**

- "Power-Tech" nitro-carburization surface treatment inhibits corrosion and provides exceptional durability for the rod and piston.
- Heavy-duty return spring (except for double-acting models) provides fast piston return & low collapsed height.
- Coupler on 9 - 45 ton models is angled upward 5° for added clearance.
- Grooved piston top keeps load from sliding.
- Cylinders can be "dead-ended" at full capacity.
- Removable carrying handles on 91 and 227 ton models.
- Complies with ANSI / ASME B30.1 safety standards.

**Technical Dimensions**

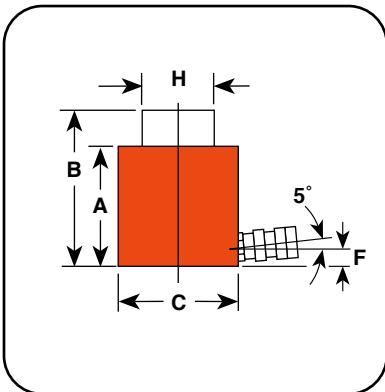

**Optional Swivel Load Caps Ordering Info**

Reduce the effects of off-center loading. Tilts up to 5 degrees. Radial grooves on top of cap reduce load slippage. Notch across face of each cap helps keep loads having a protruding or round shaped centered.

Use with Cyl. No.	Swivel Cap Order No.	Wt. (kg)	A (mm)	B (mm)	C (mm)
RSS101	350320	0,2	25,4	36,6	36,6
RSS202	350321	0,6	35,1	54,1	54,1
RSS302	350322	0,7	35,1	63,5	54,1
RSS502	350331	1,2	36,6	82,6	54,1
RSS1002	350332	3,0	46,0	111,3	85,7

**Ordering Information**

Cyl. Cap. Metric Tons (kN)*	Stroke (mm)	Order No.	Oil Cap.		A	B	C	F	H	Bore Dia. (mm)	Cylinder Effective Area (cm <sup>2</sup> )	Metric Tons at 700 (bar)	Prod. Wt. (kg)
			(cm <sup>3</sup> )		Retracted Height (mm)	Extended Height (mm)	Outside Dia. (mm)	Base to Port (mm)	Piston Rod Dia. (mm)				
			Push	Return									
9 (99)	38,1	RSS101	56	-	88,9	127,0	69,9	15,9	38,1	42,9	14,4	10,2	2,7
18 (191)	44,5	RSS202	126	-	95,3	139,7	90,5	15,9	54,8	60,3	28,6	20,0	4,5
27 (294)	62,0	RSS302	259	-	117,5	179,4	101,6	15,9	63,5	73,0	41,9	29,5	6,7
45 (490)	60,5	RSS502	374	-	127,0	187,3	123,8	19,1	79,4	88,9	62,0	43,6	10,5
91 (981)	57,2	RSS1002	725	-	139,7	196,9	168,3	23,8	111,1	127,0	126,6	89,1	21,4
91 (981)	38,1	RSS1002D*	482	212	144,5	182,6	174,6	23,8*	95,3	127,0	126,6	89,1	24,7
227 (2452)	76,2	RSS2503	2469	-	290,5	366,7	250,8	36,0	139,7	203,2	323,9	227,8	99,7

\* Note: RSS1002D is double-acting.



**Optional Cylinders Cribbing Blocks**

Cribbing blocks are shown on a 30 ton RSS302 "Shorty" cylinder. Each kit includes:

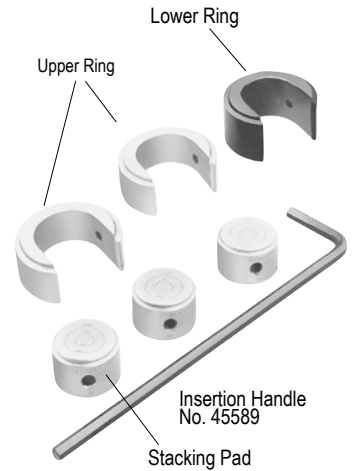

The Insertion tool (45589) is used for keeping hand from load.

**▶ Cribbing Block Ordering Information**

For Use With		27 Ton Cylinder Number RSS302			45 Ton Cylinder Number RSS502			91 Ton Cylinder Number RSS1002		
Order No.		27 Ton Set Number CB30			45 Ton Set Number CB50			91 Ton Set Number CB100		
		Lower Ring	Upper Ring	Stacking Pad	Lower Ring	Upper Ring	Stacking Pad	Lower Ring	Upper Ring	Stacking Pad
Number included in set		1	2	3	1	2	3	1	2	3
Outside Diameter	(mm)	114,30	114,30	69,85	139,70	139,70	85,85	187,71	187,71	120,7
Inside Diameter	(mm)	71,37	71,37	–	87,63	87,63	–	122,17	122,17	–
Height, each	(mm)	57,91	45,72	45,21	56,39	43,69	42,93	54,10	44,45	43,7
Total stacked height of rings in set	(mm)	149,35			143,76			187,45		
Weight of set	(kg)	9,1			12,7			29		

Note: Each set includes one Insertion Handle 45589 - 0.5" Hex x 18" Long, 4" Bend

**▶ RSS302 is perfect for any bridge construction application.**



**Cribbing Block Operation**

Convert Power Team "Shorty" cylinders to mechanical cribbing devices. They are more stable and safe than timber or other awkward, make-shift methods. Ideal for lifting applications such as structure moving. Reduces cribbing time dramatically. In effect, increases the stroke of the cylinder as stacking pads act as cylinder extensions:

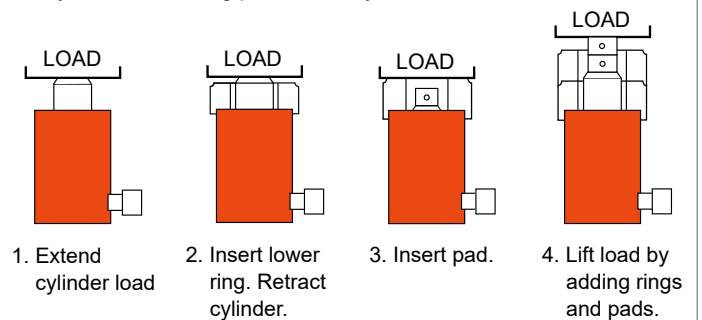

Model shown:

**RH203, RH503**



**Technical Dimensions**

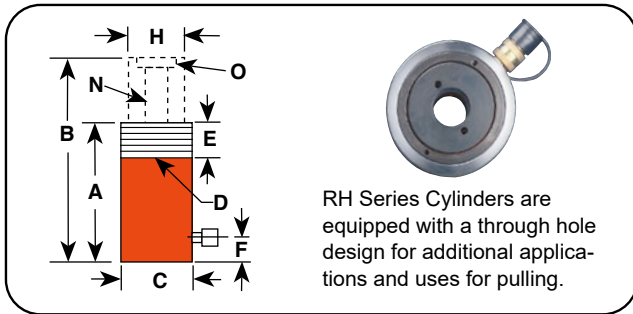

**Ordering Information**

Cyl. Cap. Metric Tons (kN)*	Stroke (mm)	Order No.	Oil Cap. (cm <sup>3</sup> )	A	B	C	D	E	F	H	N	O	Mounting Holes and Bolt Circle (in.)	Cylinder Effective Area (cm <sup>2</sup> )	Metric Tons at 700 (bar)	Prod. Wt. (kg)
				Re-tracted Height (mm)	Ex-tended Height (mm)	Outside Dia. (mm)	Collar Thread*** (in.)	Collar Thread Length (mm)	Base to Port (mm)	Piston Rod Dia. (mm)	Center Hole Dia. (mm)	Insert Thread Size (in.)				
9 (98)	65,3	RH102	91	134,9	198,4	76,2	-	-	25,4	52,4	19,4	1 3/4 - 12	1/4-20 x 60,3	14,3	10,0	4,1
	203,2	RH108	290	287,3	490,5	76,2	-	-	25,4	52,4	19,4	1 3/4 - 12	1/4-20 x 60,3	14,3	10,0	8,5
10 (118)	7,9	RH120**	14	55,6	63,5	69,9	2 3/4 - 16	31,8	9,5	34,9	17,5	3/4 - 16	5/16-18 x 50,8	17,8	12,5	1,4
	41,3	RH121	74	122,2	163,5	69,9	2 3/4 - 16	31,8	25,4	34,9	20,2	-	-	17,8	12,5	3,0
	41,3	RH121T**	74	122,2	163,5	69,9	2 3/4 - 16	31,8	25,4	34,9	17,5	3/4 - 16	5/16-18 x 50,8	17,8	12,5	3,0
	76,2	RH123	136	184,2	260,4	69,9	2 3/4 - 16	20,6	25,4	34,9	20,6	-	-	17,8	12,5	4,0
18 (196)	50,8	RH202	155	155,6	206,4	98,4	3 7/8 - 12	38,1	25,4	54,0	27,4	1 9/16 - 16	3/8-16 x 82,6	30,4	21,4	7,3
	76,2	RH203	193	154,0	230,2	101,6	-	-	25,4	69,9	26,6	2 1/4 - 12	3/8-16 x 82,6	25,3	17,8	9,1
	152,4	RH206	465	308,0	460,4	98,4	3 7/8 - 12	38,1	25,4	54,0	27,4	1 9/16 - 16	3/8-16 x 82,6	30,4	21,4	13,7
27 (294)	63,5	RH302	260	158,8	222,3	120,7	4 3/4 - 12	38,1	29,4	82,6	32,9	2 3/4 - 12	7/16-20 x 92,1	40,9	28,8	11,6
	149,2	RHA306	625	283,4	432,6	130,2	-	-	31,8	82,6	32,5	2 5/8 - 8	-	40,9	28,8	9,9
	152,4	RH306	625	247,7	400,1	120,7	4 3/4 - 12	38,1	29,4	82,6	32,5	2 3/4 - 12	7/16-20 x 92,1	40,9	28,8	17,7
45 (490)	76,2	RH503	534	181,0	257,2	152,4	6 - 12	50,8	31,8	104,8	42,5	3 1/4 - 12	5/8-18 x 120,7	70,0	49,3	21,2
54 (588)	76,2	RH603*	607	235,0	311,2	158,8	6 1/4 - 12	63,5	25,4	91,3	54,0	3 - 12	1/2-13 x 130,2	79,4	55,9	27,2
	152,4	RH606*	1211	311,2	463,6	158,8	6 1/4 - 12	63,5	25,4	91,3	54,0	3 - 12	1/2-13 x 130,2	79,4	55,9	35,4
91 (981)	76,2	RH1003*	1014	254,0	330,2	212,7	-	-	31,8	127,0	79,4	4 1/8 - 12	-	133,0	93,5	52,2

\* Supplied with carrying handles.

\*\* RH120 and RH121T do not have an internal threaded insert, but do have a 3/4-16 internal thread. The RH120 inlet port is 1/4" NPTF.

\*\*\* UN Thread

Aluminum

**Features**

**IDEAL FOR CABLE PULLING AND TENSIONING, ANCHOR BOLTS, FORCING SCREWS, ETC.**

- Cylinder body, piston and gland nut "Power-Tech" treated for corrosion and abrasion resistance.
- Most models feature threaded collar, excludes the RH203 and RHA306 models.
- All cylinders are furnished with a 9796 3/8" NPT female half coupler, except the RH120.
- Aluminum cylinder body and piston are featured on the RHA306 cylinder.
- Complies with ANSI / ASME B30.1 safety standards.



**Optional Piston Head Inserts**



For Use With:	Threaded Insert	Order No.
RH102, RH108	3/4"-16	28632
RH203	1"-8	28612
RH302, RH306	1 1/4"-7	38904
RH303	1 1/4"-7	28644
RH503	1 5/8"-51/2	38855
RH603, RH605	1 5/8"-51/2	34251



**Optional Cylinders Lifting Handles**



Lifting handle for RH303, RH306, RH306D and RHA306  
**Order Number: 252215**

Model Shown:  
**RH605**



**Technical Dimensions**

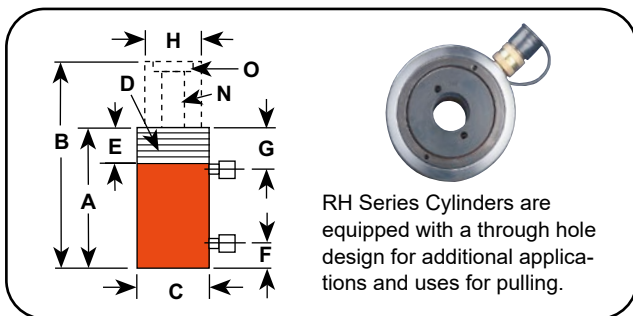

**Features**

**FOR PULLING AND TENSIONING OF CABLES, ANCHOR BOLTS, AND FORCING SCREWS.**

- Plated piston rod resists wear and superior packings provide high cycle life without leakage.
- Built-in safety feature prevents over-pressurization of the retraction circuit.
- Corrosion-resistant standpipe has “Power-Tech” treatment.
- 27, 54, 91 Ton Double-Acting Models Feature Threaded Collar.
- Aluminum cylinder body and piston are featured on the RHA604D cylinder.
- Each cylinder has 9796 3/8” NPTF female half couplers. The 60 ton thru 200 ton steel models are equipped with removable carrying handles.
- Complies with ANSI / ASME B30.1 safety standards.

**Optional Piston Head Inserts**

For Use With:	Threaded Insert	Order No.
RH102, RH108	3/4”-16	28632
RH203	1”-8	28612
RH302, RH306	1 1/4”-7	38904
RH303	1 1/4”-7	28644
RH503	1 5/8”-5 1/2	38855
RH603, RH605	1 5/8”-5 1/2	34251

**Optional Cylinders Lifting Handles**

Lifting handle for RH303 and RH306D  
**Order Number: 421312OR9**

**Ordering Information**

Cyl. Cap.	Stroke	Order No.	Oil Cap.		A	B	C	D	E	F	G	H	N	O	Mounting Holes and Bolt Circle	Cylinder Effective Area		Metric Tons at 700		Prod. Wt.	
			(ton)	(mm)	(cm <sup>3</sup> )	Re-tracted Height	Ex-tended Height	Out-side Dia.	Collar Thread**	Collar Thread Length	Base to Port	Cyl. Top to Port	Piston Rod Dia.	Center Hole Dia.		Insert Thread Size	(cm <sup>2</sup> )	(bar)	Push		Pull
Push	Pull		Push	Pull	(mm)	(mm)	(mm)	(in.)	(mm)	(mm)	(mm)	(mm)	(mm)	(in.)	(in.)	Push	Pull	Push	Pull		
27	14	76,2	RH303	289	167	179,4	255,6	120,7	-	-	25,4	41,3	63,5	32,5	2 - 12	3/8-16 x 92,1	38,0	21,8	26,8	15,3	13,5
27	14	152,4	RH306D	580	333	281,0	433,4	120,7	-	-	25,4	41,3	63,5	32,5	2 - 12	7/16-20 x 92,1	38,0	21,8	26,8	15,3	20,4
27	18	257,2	RH3010	1082	672	438,2	695,3	114,3	4 1/2 -12	41,0	44,5	81,0	60,3	33,3	1 7/8 - 16	-	42,2	26,1	29,7	18,3	27,7
54	23	101,6	RHA604D	807	338	241,3	342,9	177,8	-	-	39,7	57,2	101,6	54,0	3 - 12	1/2-13 x 130,2	79,4	33,2	55,8	25,1	16,2
54	23	127,0	RH605*	1009	423	241,3	368,3	165,9	-	-	25,4	44,5	101,6	54,0	3 - 12	1/2-13 x 130,2	79,4	33,2	55,8	25,1	33,1
54	36	257,2	RH6010*	2181	1427	458,8	716,0	155,8	6 1/4 -12	47,6	54,0	81,8	92,1	54,4	3 - 16	-	84,8	55,4	59,6	38,9	54,5
91	41	38,1	RH1001	526	233	165,1	203,2	212,7	-	-	31,8	58,7	127,0	79,8	4 - 16	5/8-11 x 177,8	138,0	60,8	97,0	42,7	38,6
91	45	152,4	RH1006*	1971	1076	314,3	466,7	184,2	-	-	37,3	59,1	111,1	52,4	-	1/2-13 x 139,7	129,2	70,5	90,8	49,6	43,1
91	41	257,2	RH10010*	3552	1556	495,3	752,5	215,9	8 1/2 -12	57,0	63,5	91,7	139,7	79,8	4 1/2 - 12	-	138,0	60,8	97,0	42,7	109,0
136	63	127,0	RH1505*	2475	1207	311,2	438,2	215,9	-	-	37,3	68,3	139,7	65,1	-	-	194,1	94,8	136,9	66,8	67,2
136	69	203,2	RH1508*	3929	2086	349,3	552,5	247,7	-	-	39,3	61,1	152,4	80,2	5 - 12	-	193,2	102,6	135,9	72,1	103,1
181	69	203,2	RH2008*	5307	2093	408,0	611,2	273,1	-	-	57,2	81,8	190,5	103,2	6 - 12	1 1/4-7 x 198,1	260,9	102,9	183,5	72,4	142,0

\* Supplied with carrying handles.

\*\* UN Thread

Aluminum

Model shown:

**RT302, RT1004**



**Features**

**IDEAL FOR PULLING AND PRESSING APPLICATION, REQUIRING HIGHER FORCES.**

- Cylinders withstand full “dead-end” loads.
- Compact design is ideal for applications in which space is limited.
- Basic head can be changed from a tapped hole to plain hole by simply changing the insert.
- Pistons have “Power-Tech” treatment for corrosion and abrasion resistance.
- Complies with ANSI / ASME B30.1 safety standards.

**Technical Dimensions, Base Mounting Holes**

Dimensions for reference only.

Single-Acting, Spring Return Cylinders

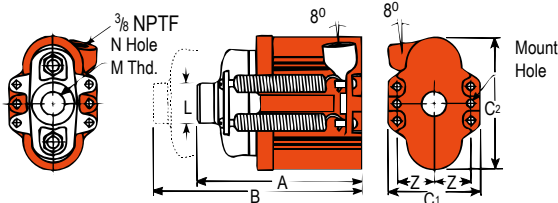

Double-Acting Cylinder (RT1004)

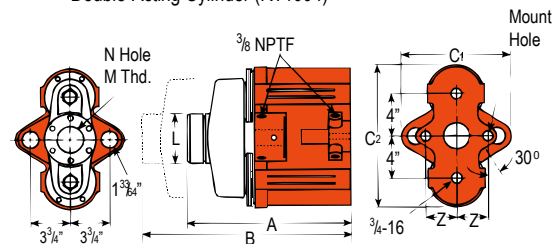

**Ordering Information**

Cyl, Cap, Metric Tons (kN)*	Stroke (mm)	Order No,	Oil Cap,		A	B	C1	C2	L	M	N	Z	Mount Hole	Cylinder Effective Area (cm <sup>2</sup> )	Metric Tons at 700		Prod, Wt , (kg)
			(cm <sup>3</sup> )		Re-tracted Height (mm)	Ex-tended Height (mm)	Outside Dia, (mm)		Load Cap Dia, (mm)	Load Cap Thread (in.)	Center Hole Dia, (mm)	Mount Hole Location (mm)			Push	Push	
			Push	Return													
16 (172)	50,8	RT172	116	-	174,6	225,4	95,3	146,1	44,5	1" - 8	27,0	38,1	8,7	22,8	16,1	6,6	
27 (294)	63,5	RT302	258	-	214,3	277,8	108,0	190,5	57,2	1 1/4" - 7	32,9	46,0	11,9	40,5	28,5	12,8	
45 (490)	76,2	RT503	482	-	268,3	344,5	149,2	238,1	73,0	1 5/8" - 5,5	42,5	60,3	16,7	63,3	44,5	25,4	
91 (981)	123,8	RT1004*	1,583	1,037	384,2	508,0	266,7	336,6	120,7	2 1/2" - 8	65,1	73,0	19,8	124,1 *	87,3	72,6	

\* The RT1004 has a bypass when full stroke is reached, preventing over-pressurization of the cylinder.  
NOTE: Each cylinder complete with threaded cylinder head insert, cylinder half coupler and cylinder attaching screws.

▶ RT Series center hole cylinder is versatile for strand or pull applications

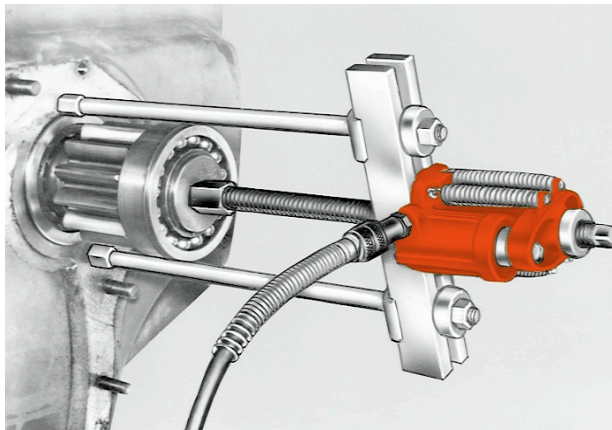

**Center Hole Design Cylinders**

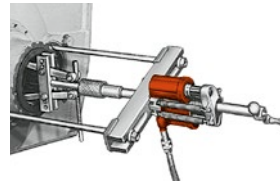

RT Series pullers are equipped with a through hole design for additional applications and uses for pulling requiring high force.

**Optional Plain Head Cylinder Inserts**



Switch from a tapped hole to a plain hole quickly with these cylinder head inserts. They are held in place with a socket screw. Plain hole permits use of a speed nut for re-adjusting cylinder after extension.

For Use With:	Threaded Order No.	Plain Order No.
RT172	21669	21714
RT302	21873	21872
RT503	22274	22275
RT1004	24197	24196

**Learn More - About Hydraulic Safety Insight**



Looking for great safety suggestions? Visit our Resource Section to get a better understanding of hydraulic and mechanical safety insights on what to look for when working around hydraulics.

▶ **Accessories Ordering Information**

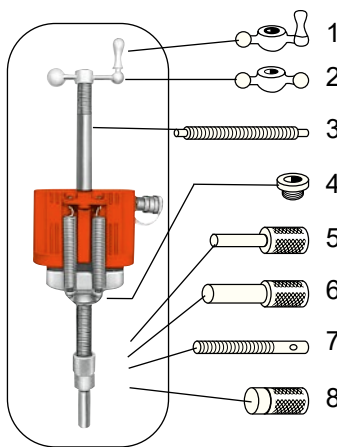

Use with Cylinder Number	No.	RT172, RH203	RT302, RH302, RH303, RH306	RT503, RH503, RH603, RH605, RH606	RT1004
Order Set		RHA20	RHA30	RHA50	RHA100
Speed Crank	1	24814	27198	29595	303785
Speed Nut	2	302482 1"-8 thread	302483 1 1/4"-7 thread	33439 1 5/8"-5 1/2 thread	34136 2 1/2"-8 thread
Adjusting Screw	3	32118 1"-8 thd. 508 mm lg.	34758 1 1/4"-7 thd. 609.6 mm lg.	32698 1 5/8"-5 1/2 thd. 762 mm lg.	32699 2 1/2"-8 thd 869.9 mm lg.
Threaded Insert	4	Threaded insert supplied with RT series cylinders. Order threaded insert for RH series cylinders with the accessory set.			
Pushing Adapter	5	201923 1"-8 thread 12.7 mm diameter shank	34510 1 1/4"-7 thread 19,1 mm diameter shank	34755 1 5/8"-5 1/2 thread 25,4 mm diameter shank	—
Pushing Adapter	6	201454 1"-8 thread 19,5 mm diameter shank	34511 1 1/4"-7 thread 25,4 mm diameter. shank	34756 1 5/8"-5 1/2 thread 31,7 mm diameter shank	—
Jack Screw	7	24813 1"-8 thd. 177,8 mm lg.	25931 1 1/4"-7 thd. 228,6 mm lg.	32701 1 5/8"-5 1/2 thd. 279,4 mm lg.	32702 2 1/2"-8 thd. 406,4 mm lg.
Screw Cap	8	28228 1"-8 thd. 38,1 mm dia.	28229 1 1/4"-7 thd 44,4 mm dia.	28230 1 5/8"-5 1/2 thd. 57,2 mm dia.	—

Model Shown:  
**RGG Family**



▶ RGG Series is perfect for any bridge construction application.



**Features**

**HEAVY LIFT, GENERAL PURPOSE CYLINDER FOR MAINTENANCE APPLICATIONS.**

- Single-Acting, load return hydraulic cylinders, tonnages ranging from 55 - 200.
- Patented swivel cap provides concentrated load centering up to 5 degrees.
- Sealing technology provides rod lubrication to reduce friction and wear.
- Floating piston design resists side loading conditions.
- "Power-Tech" nitro-carburization surface treatment inhibits corrosion and provides exceptional durability.
- Base mounting holes standard on all models.
- One high flow 3/8" NPTF female half coupler and removable eyelets are included.
- Complies with ANSI / ASME B30.1 safety standards.



**RGG Series Design Features**

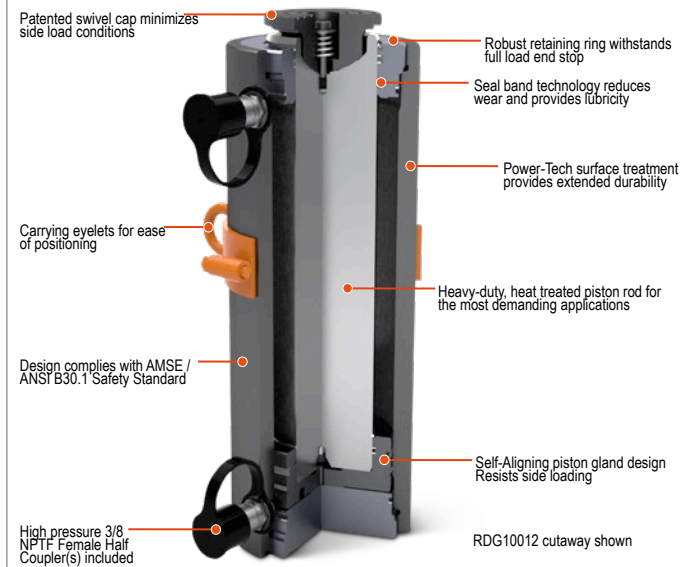

▶ **Technical Dimensions, Base Mounting Holes**

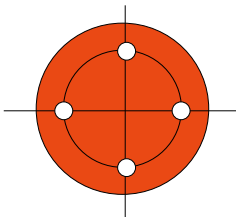

Four base mounting holes are 45° apart - standard on all models.

Tonnage	50	68	91	136	181
# of Base Mounting Holes	4	4	4	4	4
Base thread size*	M12X1,75 - 6H	M12X1,75 - 6H	M16X1,5 - 6H	M16X1,5 - 6H	M20X1,5 - 6H
Base thread depth (mm)	18,1	18,0	15,8	22,9	30,5
Base Mounting Diameter (mm)	77,0	93,0	101,6	130,1	145,3
Orientation	Mounting hole orientation is not maintained to port location.				

\*UN Thread



**Cylinder Selection**



Power Team recommends using 80% of the rated capacity and stroke to maximize product performance and safety.

Custom stroke lengths are available, contact your local Power Team Sales Office for details and availability.

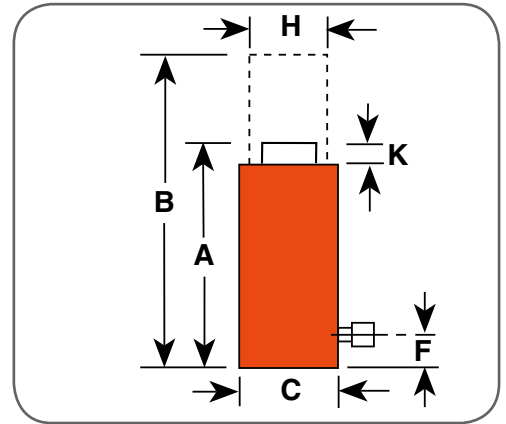

**Ordering Information**

Cyl. Cap. Metric Tons (kN)*	Stroke (mm)	Order No.	A	B	C	F	H	K	Swivel Cap Dia. (mm)	Bore Dia. (mm)	Cyl. Eff. Area (Adv-ance) (cm <sup>2</sup> )	Oil Cap. (cm <sup>3</sup> )	Metric Tons at 700 (bar)	Prod. Wt. (kg)
			Ret. Height (mm)	Ext. Height (mm)	Out. Dia. (mm)	Base to Port (mm)	Piston Rod Dia. (mm)	Swivel Cap Protrusion (mm)						
50 (539)	50,8	RGG552	199,1	249,9	131,1	41,0	69,8	17,0	70,6	95,3	71,3	362,0	50,1	17,7
	101,6	RGG554	249,9	351,5	131,1	41,0	69,8	17,0	70,6	95,3	71,3	724,0	50,1	21,7
	152,4	RGG556	300,7	453,1	131,1	41,0	69,8	17,0	70,6	95,3	71,3	1086,0	50,1	27,1
	203,2	RGG558	351,5	554,7	131,1	41,0	69,8	17,0	70,6	95,3	71,3	1448,0	50,1	31,2
	254,0	RGG5510	402,3	656,3	131,1	41,0	69,8	17,0	70,6	95,3	71,3	1809,9	50,1	35,3
	304,8	RGG5512	453,1	757,9	131,1	41,0	69,8	17,0	70,6	95,3	71,3	2171,9	50,1	39,3
	330,2	RGG5513	478,5	808,7	131,1	41,0	69,8	17,0	70,6	95,3	71,3	2352,9	50,1	41,4
	355,6	RGG5514	503,9	859,5	131,1	41,0	69,8	17,0	70,6	95,3	71,3	2533,9	50,1	43,4
68 (735)	50,8	RGG752	211,1	261,9	146,8	44,8	79,3	19,3	82,3	111,2	97,0	492,7	68,2	23,4
	101,6	RGG754	261,9	363,5	146,8	44,8	79,3	19,3	82,3	111,2	97,0	985,3	68,2	30,5
	152,4	RGG756	312,7	465,1	146,8	44,8	79,3	19,3	82,3	111,2	97,0	1478,0	68,2	35,3
	203,2	RGG758	363,5	566,7	146,8	44,8	79,3	19,3	82,3	111,2	97,0	1970,7	68,2	40,2
	254,0	RGG7510	414,3	668,3	146,8	44,8	79,3	19,3	82,3	111,2	97,0	2463,3	68,2	45,1
	304,8	RGG7512	465,1	769,9	146,8	44,8	79,3	19,3	82,3	111,2	97,0	2956,0	68,2	49,9
	330,2	RGG7513	490,5	820,7	146,8	44,8	79,3	19,3	82,3	111,2	97,0	3202,3	68,2	52,3
	355,6	RGG7514	515,9	871,5	146,8	44,8	79,3	19,3	82,3	111,2	97,0	3448,7	68,2	54,8
91 (981)	50,8	RGG1002	221,0	271,8	165,9	47,1	95,2	23,4	98,3	130,2	133,1	676,3	93,6	32,2
	101,6	RGG1004	271,8	373,4	165,9	47,1	95,2	23,4	98,3	130,2	133,1	1352,6	93,6	38,4
	152,4	RGG1006	322,6	475,0	165,9	47,1	95,2	23,4	98,3	130,2	133,1	2028,8	93,6	44,5
	203,2	RGG1008	373,4	576,6	165,9	47,1	95,2	23,4	98,3	130,2	133,1	2705,1	93,6	50,6
	254,0	RGG10010	424,2	678,2	165,9	47,1	95,2	23,4	98,3	130,2	133,1	3381,4	93,6	56,8
	304,8	RGG10012	475,0	779,8	165,9	47,1	95,2	23,4	98,3	130,2	133,1	4057,7	93,6	62,9
	330,2	RGG10013	500,4	830,6	165,9	47,1	95,2	23,4	98,3	130,2	133,1	4395,8	93,6	66,0
	355,6	RGG10014	525,8	881,4	165,9	47,1	95,2	23,4	98,3	130,2	133,1	4734,0	93,6	69,1
136 (1471)	50,8	RGG1502	238,0	288,8	195,6	53,5	114,2	24,1	117,6	158,8	198,0	1005,6	139,2	46,7
	101,6	RGG1504	288,8	390,4	195,6	53,5	114,2	24,1	117,6	158,8	198,0	2011,3	139,2	54,9
	152,4	RGG1506	339,6	492,0	195,6	53,5	114,2	24,1	117,6	158,8	198,0	3016,9	139,2	63,1
	203,2	RGG1508	390,4	593,6	195,6	53,5	114,2	24,1	117,6	158,8	198,0	4022,5	139,2	71,2
	254,0	RGG15010	441,2	695,2	195,6	53,5	114,2	24,1	117,6	158,8	198,0	5028,2	139,2	79,4
	304,8	RGG15012	492,0	796,8	195,6	53,5	114,2	24,1	117,6	158,8	198,0	6033,8	139,2	87,6
	330,2	RGG15013	517,4	847,6	195,6	53,5	114,2	24,1	117,6	158,8	198,0	6536,6	139,2	91,7
	355,6	RGG15014	542,8	898,4	195,6	53,5	114,2	24,1	117,6	158,8	198,0	7039,4	139,2	95,7
181 (1961)	50,8	RGG2002	255,0	305,8	226,8	57,2	133,3	26,9	136,4	184,2	266,3	1353,1	187,2	67,4
	101,6	RGG2004	305,8	407,4	226,8	57,2	133,3	26,9	136,4	184,2	266,3	2706,1	187,2	78,5
	152,4	RGG2006	356,6	509,0	226,8	57,2	133,3	26,9	136,4	184,2	266,3	4059,2	187,2	89,5
	203,2	RGG2008	407,4	610,6	226,8	57,2	133,3	26,9	136,4	184,2	266,3	5412,2	187,2	100,6
	254,0	RGG20010	458,2	712,2	226,8	57,2	133,3	26,9	136,4	184,2	266,3	6765,3	187,2	111,7
	304,8	RGG20012	509,0	813,8	226,8	57,2	133,3	26,9	136,4	184,2	266,3	8118,3	187,2	122,7
	330,2	RGG20013	534,4	864,6	226,8	57,2	133,3	26,9	136,4	184,2	266,3	8794,9	187,2	128,3
	355,6	RGG20014	559,8	915,4	226,8	57,2	133,3	26,9	136,4	184,2	266,3	9471,4	187,2	133,8

Model Shown:  
**RGG Family**



**Features**

**HEAVY LIFT, GENERAL PURPOSE CYLINDER FOR TOUGH MAINTENANCE APPLICATIONS.**

- Single-Acting, load return hydraulic cylinders, tonnages ranging from 227 - 544.
- Patented swivel cap provides concentrated load centering up to 5 degrees
- Sealing technology provides lubrication to reduce friction and wear.
- Floating piston design resists side loading conditions.
- "Power-Tech" nitro-carburization surface treatment inhibits corrosion and provides exceptional durability.
- Base mounting holes standard on all models (they are not maintained to port location).
- One high flow 3/8" NPTF female half coupler and removeable carry strap w/ eyelets are included.
- Complies with ANSI / ASME B30.1 safety standards.

▶ RGG Series is perfect for any building lift application.



**RGG Series Design Features**

- Patented swivel cap minimizes side load conditions
- Robust retaining ring withstands full load end stop
- Seal band technology reduces wear and provides lubricity
- Power-Tech surface treatment provides extended durability
- Carrying eyelets for ease of positioning
- Heavy-duty, heat treated piston rod for the most demanding applications
- Design complies with AMSE / ANSI B30.1 Safety Standard
- Self-Aligning piston gland design Resists side loading
- High pressure 3/8 NPTF Female Half Coupler(s) included

RDG10012 cutaway shown

▶ **Technical Dimensions, Base Mounting Holes**

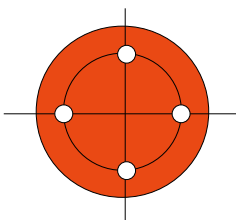

Four base mounting holes are 45° apart - standard on all models.

Tonnage	227	272	363	454	544
# of Base Mounting Holes	4	4	4	4	4
Base thread size*	M24X3,0 - 6H	M24X3,0 - 6H	M30X3,5 - 6H	M30X3,5 - 6H	M33X2,0 - 6H
Base thread depth (mm)	37,0	37,0	45,7	45,7	49,5
Base Mounting Diameter (mm)	153,9	179,3	194,3	227,3	245,1
Base Mounting Orientation	Mounting hole orientation is not maintained to port location.				

\*UN Thredad



**Cylinder Selection**



Power Team recommends using 80% of the rated capacity and stroke to maximize product performance and safety.

Custom stroke lengths are available, contact your local Power Team Sales Office for details and availability.

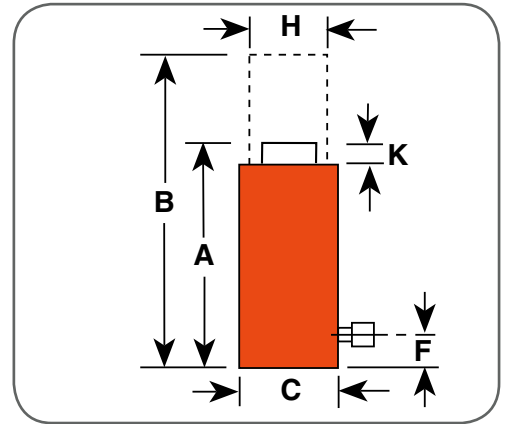

**Ordering Information**

Cyl. Cap. Metric Tons (kN)*	Stroke (mm)	Order No.	A	B	C	F	H	K	Swivel Cap Dia. (mm)	Bore Dia. (mm)	Cyl. Eff. Area (Adv-ance) (cm <sup>2</sup> )	Oil Cap. (cm <sup>3</sup> )	Metric Tons at 700 (bar)	Prod. Wt. (kg)
			Ret. Height (mm)	Ext. Height (mm)	Out. Dia. (mm)	Base to Port (mm)	Piston Rod Dia. (mm)	Swivel Cap Protru-sion (mm)						
227 (2452)	50,8	RGG2502	261,6	312,4	250,2	59,7	152,3	28,4	141,2	203,3	324,3	1647,4	228,0	87,2
	101,6	RGG2504	312,4	414,0	250,2	59,7	152,3	28,4	141,2	203,3	324,3	3294,8	228,0	101,2
	152,4	RGG2506	363,2	515,6	250,2	59,7	152,3	28,4	141,2	203,3	324,3	4942,2	228,0	115,1
	203,2	RGG2508	414,0	617,2	250,2	59,7	152,3	28,4	141,2	203,3	324,3	6589,6	228,0	129,1
	254,0	RGG25010	464,8	718,8	250,2	59,7	152,3	28,4	141,2	203,3	324,3	8237,0	228,0	143,0
	304,8	RGG25012	515,6	820,4	250,2	59,7	152,3	28,4	141,2	203,3	324,3	9884,4	228,0	156,9
	330,2	RGG25013	541,0	871,2	250,2	59,7	152,3	28,4	141,2	203,3	324,3	10708,1	228,0	163,9
	355,6	RGG25014	566,4	922,0	250,2	59,7	152,3	28,4	141,2	203,3	324,3	11531,8	228,0	170,9
272 (2942)	50,8	RGG3002	272,8	323,6	281,4	63,0	165,0	32,5	169,2	228,7	410,4	2084,9	288,5	114,0
	101,6	RGG3004	323,6	425,2	281,4	63,0	165,0	32,5	169,2	228,7	410,4	4169,7	288,5	131,0
	152,4	RGG3006	374,4	526,8	281,4	63,0	165,0	32,5	169,2	228,7	410,4	6254,6	288,5	148,0
	203,2	RGG3008	425,2	628,4	281,4	63,0	165,0	32,5	169,2	228,7	410,4	8339,5	288,5	164,5
	254,0	RGG30010	476,0	730,0	281,4	63,0	165,0	32,5	169,2	228,7	410,4	10424,3	288,5	182,0
	304,8	RGG30012	526,8	831,6	281,4	63,0	165,0	32,5	169,2	228,7	410,4	12509,2	288,5	198,9
	330,2	RGG30013	552,2	882,4	281,4	63,0	165,0	32,5	169,2	228,7	410,4	13551,6	288,5	207,4
	355,6	RGG30014	577,6	933,2	281,4	63,0	165,0	32,5	169,2	228,7	410,4	14594,1	288,5	215,9
363 (3923)	50,8	RGG4002	306,6	357,4	328,4	70,3	190,4	37,1	197,4	266,8	558,6	2837,6	392,6	177,2
	101,6	RGG4004	357,4	459,0	328,4	70,3	190,4	37,1	197,4	266,8	558,6	5675,1	392,6	200,1
	152,4	RGG4006	408,2	560,6	328,4	70,3	190,4	37,1	197,4	266,8	558,6	8512,7	392,6	223,0
	203,2	RGG4008	459,0	662,2	328,4	70,3	190,4	37,1	197,4	266,8	558,6	11350,2	392,6	245,8
	254,0	RGG40010	509,8	763,8	328,4	70,3	190,4	37,1	197,4	266,8	558,6	14187,8	392,6	268,7
	304,8	RGG40012	560,6	865,4	328,4	70,3	190,4	37,1	197,4	266,8	558,6	17025,4	392,6	291,6
	330,2	RGG40013	586,0	916,2	328,4	70,3	190,4	37,1	197,4	266,8	558,6	18444,1	392,6	303,0
	355,6	RGG40014	611,4	967,0	328,4	70,3	190,4	37,1	197,4	266,8	558,6	19862,9	392,6	314,5
454 (4903)	50,8	RGG5002	311,9	362,7	359,7	73,6	203,1	39,4	216,2	292,2	670,0	3403,7	471,0	205,0
	101,6	RGG5004	362,7	464,3	359,7	73,6	203,1	39,4	216,2	292,2	670,0	6807,3	471,0	240,6
	152,4	RGG5006	413,5	565,9	359,7	73,6	203,1	39,4	216,2	292,2	670,0	10211,0	471,0	267,4
	203,2	RGG5008	464,3	667,5	359,7	73,6	203,1	39,4	216,2	292,2	670,0	13614,7	471,0	294,1
	254,0	RGG50010	515,1	769,1	359,7	73,6	203,1	39,4	216,2	292,2	670,0	17018,4	471,0	320,8
	304,8	RGG50012	565,9	870,7	359,7	73,6	203,1	39,4	216,2	292,2	670,0	20422,0	471,0	347,5
	330,2	RGG50013	591,3	921,5	359,7	73,6	203,1	39,4	216,2	292,2	670,0	22123,9	471,0	360,9
	355,6	RGG50014	616,7	972,3	359,7	73,6	203,1	39,4	216,2	292,2	670,0	23825,7	471,0	374,3
544 (5884)	50,8	RGG6002	324,1	374,9	391,2	76,8	228,5	41,4	235,0	317,6	791,6	4021,2	556,4	255,0
	101,6	RGG6004	374,9	476,5	391,2	76,8	228,5	41,4	235,0	317,6	791,6	8042,5	556,4	287,7
	152,4	RGG6006	425,7	578,1	391,2	76,8	228,5	41,4	235,0	317,6	791,6	12063,7	556,4	320,5
	203,2	RGG6008	476,5	679,7	391,2	76,8	228,5	41,4	235,0	317,6	791,6	16085,0	556,4	353,2
	254,0	RGG60010	527,3	781,3	391,2	76,8	228,5	41,4	235,0	317,6	791,6	20106,2	556,4	385,9
	304,8	RGG60012	578,1	882,9	391,2	76,8	228,5	41,4	235,0	317,6	791,6	24127,4	556,4	418,7
	330,2	RGG60013	603,5	933,7	391,2	76,8	228,5	41,4	235,0	317,6	791,6	26138,0	556,4	435,0
	355,6	RGG60014	628,9	984,5	391,2	76,8	228,5	41,4	235,0	317,6	791,6	28148,7	556,4	451,4

Model Shown:  
**RDG Family**



**Features**

**HEAVY LIFT, GENERAL PURPOSE CYLINDER FOR TOUGH MRO APPLICATIONS.**

- Double-Acting, hydraulic return cylinders, tonnages ranging from 50-181.
- Patented swivel cap provides concentrated load centering up to 5 degrees.
- Safety relief valve prevents over-pressurization of the retract circuit.
- Sealing technology provides lubrication to reduce friction and wear.
- "Power-Tech" nitro-carburization surface treatment inhibits corrosion and provides exceptional durability.
- Floating piston design resists side loading conditions.
- Base mounting holes standard on all models (they are not maintained to port location).
- Two high flow 3/8" NPTF female half coupler and removeable carry strap w/ eyelets are included.
- Complies with ANSI / ASME B30.1 safety standards.

▶ RDG Series is perfect choice for any heavy lift MRO application.



**RDG Series Design Features**

- Patented swivel cap minimizes side load conditions
- Robust retaining ring withstands full load end stop
- Seal band technology reduces wear and provides lubricity
- Power-Tech surface treatment provides extended durability
- Carrying eyelets for ease of positioning
- Heavy-duty, heat treated piston rod for the most demanding applications
- Design complies with AMSE / ANST B30.1 Safety Standard
- Self-Aligning piston gland design Resists 'side' loading
- High pressure 3/8" NPTF Female Half Coupler(s) included

RDG10012 cutaway shown

**Technical Dimensions, Base Mounting Holes**

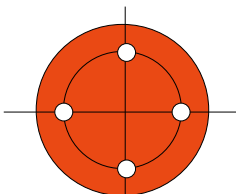

Four base mounting holes are 45° apart - standard on all models.

Tonnage	50	68	91	136	181
# of Base Mounting Holes	4	4	4	4	4
Base thread size	M12X1,75 - 6H	M12X1,75 - 6H	M16X1,5 - 6H	M16X1,5 - 6H	M20X1,5 - 6H
Base thread depth (mm)	18,0	18,0	15,7	22,9	30,5
Base Mounting Diameter (mm)	77,0	93,0	101,6	139,1	145,3
Orientation	Mounting hole orientation is not maintained to port location.				

\*UN Thread



**Cylinder Selection**



Power Team recommends using 80% of the rated capacity and stroke to maximize product performance and safety.

Custom stroke lengths are available, contact your local Power Team Sales Office for details and availability.

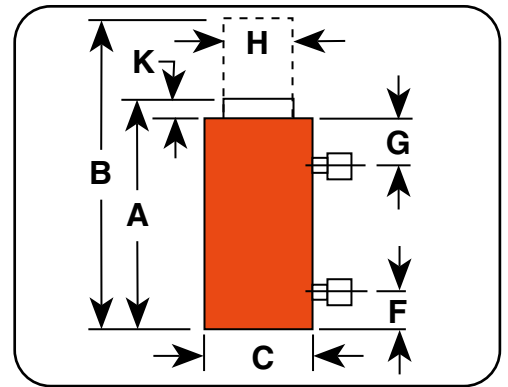

**Ordering Information**

Cyl. Cap. Metric Tons (kN)*	Stroke (mm)	Order No.	A	B	C	F	G	H	K	Swivel Cap Dia. (mm)	Bore Dia. (mm)	Cyl. Eff. Area (Adv-ance) (cm <sup>2</sup> )	Oil Cap. (Ext.) (cm <sup>3</sup> )	Oil Cap. (Ret.) (cm <sup>3</sup> )	Metric Tons at 700 (bar)	Prod. Wt. (kg)
			Ret. Height (mm)	Ext. Height (mm)	Outside Dia. (mm)	Base to Port (mm)	Top to Port (mm)	Piston Rod Dia. (mm)	Swivel Cap Pro-trusion (mm)							
50 (539)	50,8	RDG552	199,1	249,9	131,1	41,0	41,0	69,8	17,0	70,6	95,3	71,3	362,0	167,6	50,1	17,8
	101,6	RDG554	249,9	351,5	131,1	41,0	41,0	69,8	17,0	70,6	95,3	71,3	724,0	335,1	50,1	21,9
	152,4	RDG556	300,7	453,1	131,1	41,0	41,0	69,8	17,0	70,6	95,3	71,3	1086,0	502,7	50,1	27,3
	203,2	RDG558	351,5	554,7	131,1	41,0	41,0	69,8	17,0	70,6	95,3	71,3	1448,0	670,3	50,1	31,4
	254,0	RDG5510	402,3	656,3	131,1	41,0	41,0	69,8	17,0	70,6	95,3	71,3	1809,9	837,8	50,1	35,4
	304,8	RDG5512	453,1	757,9	131,1	41,0	41,0	69,8	17,0	70,6	95,3	71,3	2171,9	1005,4	50,1	39,5
	330,2	RDG5513	478,5	808,7	131,1	41,0	41,0	69,8	17,0	70,6	95,3	71,3	2352,9	1089,2	50,1	41,5
	355,6	RDG5514	503,9	859,5	131,1	41,0	41,0	69,8	17,0	70,6	95,3	71,3	2533,9	1173,0	50,1	43,5
68 (735)	50,8	RDG752	211,1	261,9	146,8	44,8	44,8	79,3	19,3	82,3	111,2	97,0	492,7	241,6	68,2	23,4
	101,6	RDG754	261,9	363,5	146,8	44,8	44,8	79,3	19,3	82,3	111,2	97,0	985,3	483,2	68,2	30,6
	152,4	RDG756	312,7	465,1	146,8	44,8	44,8	79,3	19,3	82,3	111,2	97,0	1478,0	724,7	68,2	35,5
	203,2	RDG758	363,5	566,7	146,8	44,8	44,8	79,3	19,3	82,3	111,2	97,0	1970,7	966,3	68,2	40,4
	254,0	RDG7510	414,3	668,3	146,8	44,8	44,8	79,3	19,3	82,3	111,2	97,0	2463,3	1207,9	68,2	45,2
	304,8	RDG7512	465,1	769,9	146,8	44,8	44,8	79,3	19,3	82,3	111,2	97,0	2956,0	1449,5	68,2	50,1
	330,2	RDG7513	490,5	820,7	146,8	44,8	44,8	79,3	19,3	82,3	111,2	97,0	3202,3	1570,3	68,2	52,5
	355,6	RDG7514	515,9	871,5	146,8	44,8	44,8	79,3	19,3	82,3	111,2	97,0	3448,7	1691,1	68,2	55,0
91 (981)	50,8	RDG1002	221,0	271,8	165,9	47,1	47,1	95,2	23,4	98,3	130,2	133,1	676,3	314,9	93,5	32,3
	101,6	RDG1004	271,8	373,4	165,9	47,1	47,1	95,2	23,4	98,3	130,2	133,1	1352,6	629,7	93,5	38,4
	152,4	RDG1006	322,6	475,0	165,9	47,1	47,1	95,2	23,4	98,3	130,2	133,1	2028,8	944,6	93,5	44,5
	203,2	RDG1008	373,4	576,6	165,9	47,1	47,1	95,2	23,4	98,3	130,2	133,1	2705,1	1259,5	93,5	50,7
	254,0	RDG10010	424,2	678,2	165,9	47,1	47,1	95,2	23,4	98,3	130,2	133,1	3381,4	1574,4	93,5	56,8
	304,8	RDG10012	475,0	779,8	165,9	47,1	47,1	95,2	23,4	98,3	130,2	133,1	4057,7	1889,2	93,5	63,0
	330,2	RDG10013	500,4	830,6	165,9	47,1	47,1	95,2	23,4	98,3	130,2	133,1	4395,8	2046,7	93,5	66,0
	355,6	RDG10014	525,8	881,4	165,9	47,1	47,1	95,2	23,4	98,3	130,2	133,1	4734,0	2204,1	93,5	69,1
136 (1471)	50,8	RDG1502	238,0	288,8	195,6	53,5	53,5	114,2	24,1	117,6	158,8	198,0	1005,6	485,1	139,1	46,8
	101,6	RDG1504	288,8	390,4	195,6	53,5	53,5	114,2	24,1	117,6	158,8	198,0	2011,3	970,2	139,1	54,9
	152,4	RDG1506	339,6	492,0	195,6	53,5	53,5	114,2	24,1	117,6	158,8	198,0	3016,9	1455,3	139,1	63,1
	203,2	RDG1508	390,4	583,6	195,6	53,5	53,5	114,2	24,1	117,6	158,8	198,0	4022,5	1940,4	139,1	71,3
	254,0	RDG15010	441,2	695,2	195,6	53,5	53,5	114,2	24,1	117,6	158,8	198,0	5028,2	2425,5	139,1	79,5
	304,8	RDG15012	492,0	796,8	195,6	53,5	53,5	114,2	24,1	117,6	158,8	198,0	6033,8	2910,7	139,1	87,7
	330,2	RDG15013	517,4	847,6	195,6	53,5	53,5	114,2	24,1	117,6	158,8	198,0	6536,6	3153,2	139,1	91,8
	355,6	RDG15014	542,8	898,4	195,6	53,5	53,5	114,2	24,1	117,6	158,8	198,0	7039,4	3395,8	139,1	95,8
181 (1961)	50,8	RDG2002	255,0	305,8	226,8	57,2	57,2	133,3	26,9	136,4	184,2	266,3	1353,1	644,5	187,2	67,5
	101,6	RDG2004	305,8	407,4	226,8	57,2	57,2	133,3	26,9	136,4	184,2	266,3	2706,1	1289,0	187,2	78,6
	152,4	RDG2006	356,6	509,0	226,8	57,2	57,2	133,3	26,9	136,4	184,2	266,3	4059,2	1933,4	187,2	89,6
	203,2	RDG2008	407,4	610,6	226,8	57,2	57,2	133,3	26,9	136,4	184,2	266,3	5412,2	2577,9	187,2	100,7
	254,0	RDG20010	458,2	712,2	226,8	57,2	57,2	133,3	26,9	136,4	184,2	266,3	6765,3	3222,4	187,2	111,8
	304,8	RDG20012	509,0	813,8	226,8	57,2	57,2	133,3	26,9	136,4	184,2	266,3	8118,3	3866,9	187,2	122,8
	330,2	RDG20013	534,4	864,6	226,8	57,2	57,2	133,3	26,9	136,4	184,2	266,3	8794,9	4189,1	187,2	128,3
	355,6	RDG20014	559,8	915,4	226,8	57,2	57,2	133,3	26,9	136,4	184,2	266,3	9471,4	4511,4	187,2	133,9

Model Shown:  
**RDG Family**



**Features**

**HEAVY LIFT, GENERAL PURPOSE CYLINDER FOR TOUGH MAINTENANCE APPLICATIONS.**

- Double-Acting, hydraulic return cylinders, tonnages ranging from 227 - 544.
- Patented swivel cap provides concentrated load centering up to 5 degrees.
- Safety relief valve prevents over-pressurization of the retract circuit.
- Sealing technology provides lubrication to reduce friction and wear.
- "Power-Tech" nitro-carburization surface treatment inhibits corrosion and provides exceptional durability.
- Floating piston design resists side loading conditions.
- Two high flow 3/8" NPTF female half coupler and removable carry strap w/ eyelets are included.
- Base mounting holes standard on all models (they are not maintained to port location).
- Complies with ANSI / ASME B30.1 safety standards.

▶ RDG Series is perfect for mining MRO application.



**RDG Series Design Features**

Patented swivel cap minimizes side load conditions

Robust retaining ring withstands full load end stop

Seal band technology reduces wear and provides lubricity

Power-Tech surface treatment provides extended durability

Carrying eyelets for ease of positioning

Heavy-duty, heat treated piston rod for the most demanding applications

Design complies with AMSE / ANSI B30.1 Safety Standard

Self-Aligning piston gland design Resists side loading

High pressure 3/8 NPTF Female Half Coupler(s) included

RDG10012 cutaway shown

**Technical Dimensions, Base Mounting Holes**

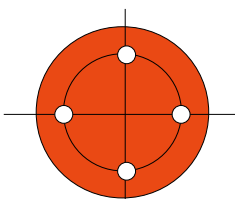

Four base mounting holes are 45° apart - standard on all models.

Tonnage	227	272	363	454	544
# of Base Mounting Holes	4	4	4	4	4
Base thread size*	M24X3,0 - 6H	M24X3,0 - 6H	M30X3,5 - 6H	M30X3,5 - 6H	M33X2,0 - 6H
Base thread depth (mm)	37,0	37,0	45,7	45,7	49,5
Base Mounting Diameter (mm)	153,9	179,3	194,3	227,3	245,1
Orientation	Mounting hole orientation is not maintained to port location.				

\*UN Thread



**Cylinder Selection**



Power Team recommends using 80% of the rated capacity and stroke to maximize product performance and safety.

Custom stroke lengths are available, contact your local Power Team Sales Office for details and availability.

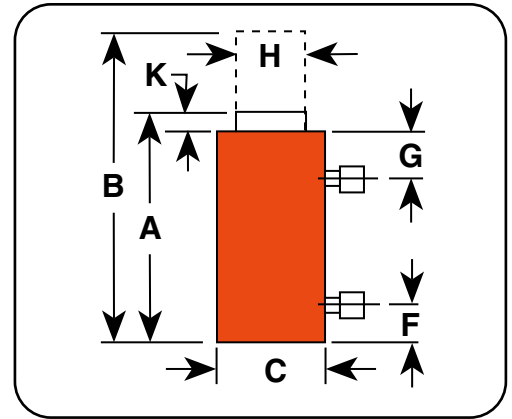

**Ordering Information**

Cyl. Cap. Metric Tons (kN)*	Stroke (mm)	Order No.	A	B	C	F	G	H	K	Swivel Cap Dia. (mm)	Bore Dia. (mm)	Cyl. Eff. Area (Advance) (cm <sup>2</sup> )	Oil Cap. (Ext.) (cm <sup>3</sup> )	Oil Cap. (Ret.) (cm <sup>3</sup> )	Metric Tons at 700 (bar)	Prod. Wt. (kg)
			Ref. Height (mm)	Ext. Height (mm)	Out-side Dia. (mm)	Base to Port (mm)	Top to Port (mm)	Piston Rod Dia. (mm)	Swivel Cap Protrusion (mm)							
227 (2452)	50,8	RDG2502	261,6	312,4	250,2	59,7	59,7	152,3	28,4	141,2	203,3	324,3	1647,4	721,8	227,9	87,3
	101,6	RDG2504	312,4	414,0	250,2	59,7	59,7	152,3	28,4	141,2	203,3	324,3	3294,8	1443,6	227,9	101,2
	152,4	RDG2506	363,2	515,6	250,2	59,7	59,7	152,3	28,4	141,2	203,3	324,3	4942,2	2165,4	227,9	115,2
	203,2	RDG2508	414,0	617,2	250,2	59,7	59,7	152,3	28,4	141,2	203,3	324,3	6589,6	2887,3	227,9	129,2
	254,0	RDG25010	464,8	718,8	250,2	59,7	59,7	152,3	28,4	141,2	203,3	324,3	8237,0	3609,1	227,9	143,1
	304,8	RDG25012	515,6	820,4	250,2	59,7	59,7	152,3	28,4	141,2	203,3	324,3	9884,4	4330,9	227,9	157,0
	330,2	RDG25013	541,0	871,2	250,2	59,7	59,7	152,3	28,4	141,2	203,3	324,3	10708,1	4691,8	227,9	164,0
	355,6	RDG25014	566,4	922,0	250,2	59,7	59,7	152,3	28,4	141,2	203,3	324,3	11531,8	5052,7	227,9	171,0
272 (2942)	50,8	RDG3002	272,8	323,6	281,4	63,0	63,0	165,0	32,5	169,2	228,7	410,4	2084,9	998,5	288,5	114,1
	101,6	RDG3004	323,6	425,2	281,4	63,0	63,0	165,0	32,5	169,2	228,7	410,4	4169,7	1997,1	288,5	131,1
	152,4	RDG3006	374,4	526,8	281,4	63,0	63,0	165,0	32,5	169,2	228,7	410,4	6254,6	2995,6	288,5	148,1
	203,2	RDG3008	425,2	628,4	281,4	63,0	63,0	165,0	32,5	169,2	228,7	410,4	8339,5	3994,2	288,5	165,1
	254,0	RDG30010	476,0	730,0	281,4	63,0	63,0	165,0	32,5	169,2	228,7	410,4	10424,3	4992,7	288,5	182,1
	304,8	RDG30012	526,8	831,6	281,4	63,0	63,0	165,0	32,5	169,2	228,7	410,4	12509,2	5991,3	288,5	199,0
	330,2	RDG30013	552,2	882,4	281,4	63,0	63,0	165,0	32,5	169,2	228,7	410,4	13551,6	6490,5	288,5	207,5
	355,6	RDG30014	577,6	933,2	281,4	63,0	63,0	165,0	32,5	169,2	228,7	410,4	14594,1	6989,8	288,5	216,0
363 (3923)	50,8	RDG4002	306,6	357,4	328,4	70,3	70,3	190,4	37,1	197,4	266,8	558,6	2837,6	1391,1	392,7	177,3
	101,6	RDG4004	357,4	459,0	328,4	70,3	70,3	190,4	37,1	197,4	266,8	558,6	5675,1	2782,3	392,7	200,2
	152,4	RDG4006	408,2	560,6	328,4	70,3	70,3	190,4	37,1	197,4	266,8	558,6	8512,7	4173,4	392,7	223,1
	203,2	RDG4008	459,0	662,2	328,4	70,3	70,3	190,4	37,1	197,4	266,8	558,6	11350,2	5564,6	392,7	245,9
	254,0	RDG40010	509,8	763,8	328,4	70,3	70,3	190,4	37,1	197,4	266,8	558,6	14187,8	6955,7	392,7	268,8
	304,8	RDG40012	560,6	865,4	328,4	70,3	70,3	190,4	37,1	197,4	266,8	558,6	17025,4	8346,9	392,7	288,6
	330,2	RDG40013	586,0	916,2	328,4	70,3	70,3	190,4	37,1	197,4	266,8	558,6	18444,1	9042,5	392,7	303,1
	355,6	RDG40014	611,4	967,0	328,4	70,3	70,3	190,4	37,1	197,4	266,8	558,6	19862,9	9738,0	392,7	314,6
454 (4903)	50,8	RDG5002	311,9	362,7	359,7	73,6	73,6	203,1	39,4	216,2	292,2	670,0	3403,7	1757,9	471,0	214,0
	101,6	RDG5004	362,7	464,3	359,7	73,6	73,6	203,1	39,4	216,2	292,2	670,0	6807,3	3515,8	471,0	240,7
	152,4	RDG5006	413,5	565,9	359,7	73,6	73,6	203,1	39,4	216,2	292,2	670,0	10211,0	5273,8	471,0	267,5
	203,2	RDG5008	464,3	667,5	359,7	73,6	73,6	203,1	39,4	216,2	292,2	670,0	13614,7	7031,7	471,0	294,1
	254,0	RDG50010	515,1	769,1	359,7	73,6	73,6	203,1	39,4	216,2	292,2	670,0	17018,4	8789,6	471,0	320,9
	304,8	RDG50012	565,9	870,7	359,7	73,6	73,6	203,1	39,4	216,2	292,2	670,0	20422,0	10547,5	471,0	347,6
	330,2	RDG50013	591,3	921,5	359,7	73,6	73,6	203,1	39,4	216,2	292,2	670,0	22123,9	11426,5	471,0	361,0
	355,6	RDG50014	616,7	972,3	359,7	73,6	73,6	203,1	39,4	216,2	292,2	670,0	23825,7	12305,5	471,0	374,4
544 (5884)	50,8	RDG6002	324,1	374,9	391,2	76,8	76,8	228,5	41,4	235,0	317,6	791,6	4021,2	1938,2	556,5	255,2
	101,6	RDG6004	374,9	476,5	391,2	76,8	76,8	228,5	41,4	235,0	317,6	791,6	8042,5	3876,4	556,5	288,0
	152,4	RDG6006	425,7	578,1	391,2	76,8	76,8	228,5	41,4	235,0	317,6	791,6	12063,7	5814,7	556,5	320,7
	203,2	RDG6008	476,5	679,7	391,2	76,8	76,8	228,5	41,4	235,0	317,6	791,6	16085,0	7752,9	556,5	353,4
	254,0	RDG60010	527,3	781,3	391,2	76,8	76,8	228,5	41,4	235,0	317,6	791,6	20106,2	9691,1	556,5	386,2
	304,8	RDG60012	578,1	882,9	391,2	76,8	76,8	228,5	41,4	235,0	317,6	791,6	24127,4	11629,3	556,5	418,9
	330,2	RDG60013	603,5	933,7	391,2	76,8	76,8	228,5	41,4	235,0	317,6	791,6	26138,0	12598,4	556,5	435,2
	355,6	RDG60014	628,9	984,5	391,2	76,8	76,8	228,5	41,4	235,0	317,6	791,6	28148,7	13567,5	556,5	451,6

Model Shown:

**RD10013, RD556, RD300**



▶ Four special order 500 ton, 610 mm stroke cylinders used in a swaging press for crimping 89 mm wire rope.



**Features**

**HIGH TONNAGE PREMIUM DESIGN FOR HIGH CYCLE LIFE.**

- Perfect for bridge lifting, building reconstruction, shipyard, utility and mining equipment maintenance.
- Aluminum bronze overlay bearings provide long life.
- Chrome plated piston rod resists corrosion.
- Rod and collar threads are designed to withstand full tonnage.
- Grooved ring pattern in load cap helps guard against load slippage.
- Each cylinder has two 9796 3/8" NPTF female half couplers.
- Built-in safety relief valve prevents over-pressurization of the retract circuit.
- Feature mounting holes and collar threads.
- Complies with ANSI / ASME B30.1 safety standards.



**RD Series Design Features**

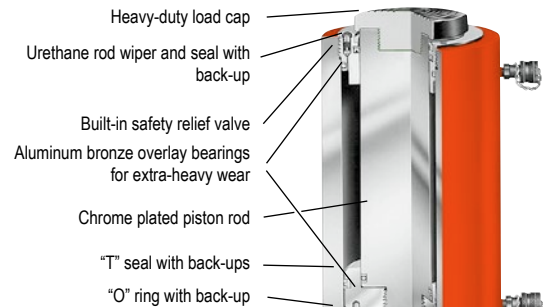

**RD Series Performance**

The table at right gives you an idea of what to expect when coupling RD series cylinders to a Power Team pump. Actual performance will vary according to job conditions.

Pump	Cylinder	Time to Extend Cylinder 25,4 mm	
		7 bar	700 bar
PE55	RD55	1,0 sec,	12,0 sec,
	RD100	1,8 sec,	22,5 sec,
	RD200	3,5 sec,	45,0 sec,
	RD400	7,2 sec,	92,0 sec,
PQ120 Series	RD200	3,4 sec,	20,6 sec,
	RD300	4,9 sec,	30,0 sec,
	RD400	6,4 sec,	39,0 sec,
PE400 Series	RD500	8,1 sec,	49,5 sec,
	RD300	3,0 sec,	8,5 sec,
	RD400	3,9 sec,	11,1 sec,
	RD500	4,9 sec,	14,1 sec,

**Technical Dimensions, Base Mounting Holes**

Cylinder Tonnage	9	23	50	73	91	136	181	272	363	454
# of Holes	2	4	4	4	4	4	4	4	4	6
Thread Size*	3/8"-16	1/2"-13	5/8"-11	5/8"-11	3/4"-10	1"-8	1 1/4"-7	1 1/4"-7	1 1/2"-12	1 3/8"-12
Thread Depth (mm)	16	19	22	22	25	25	32	44	48	51
Bolt Circle Diameter (mm)	51	70	89	114	140	152	165	159	184	203
Orientation*	90°	45°	45°	45°	45°	45°	45°	Random	Random	Random

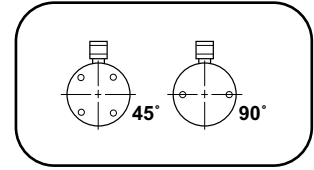

NOTE: Base mounting holes are standard on all RD cylinders. \*Orientation of base mounting holes to coupler.

\*UN Thread

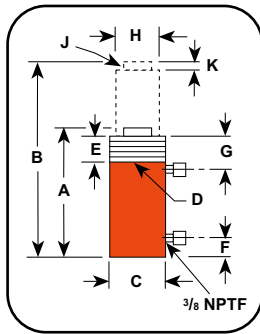

**Optional Swivel Load Caps Ordering Info**

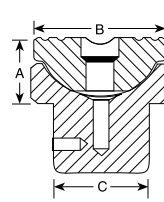

Cylinder Tonnage	Swivel Cap Order No.	Wt. (kg)	A (mm)	B (mm)	C (mm)
9	350144	0,4	22,2	36,5	21,8
23	350145	0,6	28,6	54,0	36,5
50	351325	1,9	61,9	63,5	39,3
91	351324	5,1	75,0	95,3	67,5
136 / 181	351334	5,8	66,7	111,1	77,8

**Ordering Information**

Cyl. Cap. (ton)	Stroke (mm)	Order No.	Oil Cap. (cm³)		A	B	C	D	E	F	G	H	J	K	Load Cap. Dia. (mm)	Bore Dia. (mm)	Cylinder Effective Area (cm²)		Metric Tons at 700 (bar)		Prod. Wt. (kg)	
			Re-tracted Height (mm)	Ex-tended Height (mm)	Outside Dia. (mm)	Collar Thread Size* (in.)	Thread Length Thread (mm)	Base to Port (mm)	Cyl. Piston Top to Port (mm)	Piston Rod Dia. (mm)	Rod Int. Thread & Depth* (in.)	Piston Rod Protru-sion (mm)	Push	Pull			Push	Pull				
9	4	158,8	RD106	228	90	296,9	455,6	76,2	2 3/4 - 12	41,3	25,4	63,5	33,3	1-8 x 25,4	6,4	34,9	42,9	14,4	5,7	10,2	4,0	10,0
	4	254,0	RD1010	366	144	398,5	652,5	76,2	2 3/4 - 12	41,3	25,4	63,5	33,3	1-8 x 25,4	6,4	34,9	42,9	14,4	5,7	10,2	4,0	12,7
23	7	158,8	RD256	528	166	314,3	473,1	101,6	4 - 12	41,3	25,4	63,5	54,0	1 1/2-16 x 25,4	9,5	54,0	65,1	33,2	10,4	23,4	7,3	18,1
	7	362,0	RD2514	1205	376	517,5	879,5	101,6	4 - 12	41,3	25,4	63,5	54,0	1 1/2-16 x 25,4	9,5	54,0	65,1	33,2	10,4	23,4	7,3	29,5
50	25	158,8	RD556	1132	577	329,4	488,2	127,0	5 - 12	41,3	33,3	63,5	66,7	1 1/16-8 x 30,2	15,9	66,7	95,3	71,2	36,3	50,1	25,6	27,9
	25	333,4	RD5513	2376	1212	504,0	837,4	127,0	5 - 12	41,3	33,3	63,5	66,7	1 1/16-8 x 30,2	15,9	66,7	95,3	71,2	36,3	50,1	25,6	40,9
	25	460,4	RD5518	3280	1673	657,2	1117,6	127,0	5 - 12	41,3	33,3	63,5	66,7	1 1/16-8 x 30,2	15,9	66,7	95,3	71,2	36,3	50,1	25,6	64,5
73	40	333,4	RD8013	3421	1901	517,5	850,9	146,1	5 3/4 - 12	41,3	38,1	63,5	76,2	2-4 1/2 x 38,1	14,3	73,0	114,3	102,6	57,0	72,1	40,1	53,6
	40	168,3	RD1006	2242	959	350,0	518,3	174,6	6 7/8 - 12	41,3	38,1	63,5	98,4	2 3/4-12 x 29,4	15,9	98,4	130,2	133,1	57,0	93,5	40,1	57,2
91	40	333,4	RD10013	4440	1902	515,1	848,5	174,6	6 7/8 - 12	41,3	38,1	63,5	98,4	2 3/4-12 x 29,4	15,9	98,4	130,2	133,1	57,0	93,5	40,1	82,2
	40	511,2	RD10020	6809	2919	718,3	1229,5	174,6	6 7/8 - 12	41,3	38,1	63,5	98,4	2 3/4-12 x 29,4	15,9	98,4	130,2	133,1	57,0	93,5	40,1	118,0
136	66	168,3	RD1506	3334	1606	377,8	546,1	209,6	8 1/4 - 12	41,3	50,8	63,5	114,3	3 1/4-8 x 38,1	20,6	114,3	158,8	197,9	95,3	139,1	66,9	85,4
	66	333,4	RD15013	6604	3180	542,9	876,3	209,6	8 1/4 - 12	41,3	50,8	63,5	114,3	3 1/4-8 x 38,1	20,6	114,3	158,8	197,9	95,3	139,1	66,9	123,5
	66	460,4	RD15018	9132	4392	673,9	1134,3	209,6	8 1/4 - 12	41,3	50,8	63,5	114,3	3 1/4-8 x 38,1	19,1	114,3	158,8	197,9	95,3	139,1	66,9	170,7
181	102	168,3	RD2006	4485	2457	406,4	574,7	241,3	9 1/2 - 12	41,3	63,5	68,3	123,8	3 1/4-8 x 57,1	27,0	114,3	184,2	266,3	145,9	187,2	102,6	118,9
	102	333,4	RD20013	8886	4869	571,5	904,9	241,3	9 1/2 - 12	41,3	63,5	68,3	123,8	3 1/4-8 x 57,1	27,0	114,3	184,2	266,3	145,9	187,2	102,6	161,6
	102	460,4	RD20018	12270	6722	723,9	1184,3	241,3	9 1/2 - 12	41,3	63,5	68,3	123,8	3 1/4-8 x 57,1	27,0	114,3	184,2	266,3	145,9	187,2	102,6	200,7
272	133	152,4	RD3006	5920	2903	488,9	591,3	273,1	10 1/2 - 12	60,3	85,7	85,7	158,8	2 1/2-12 x 82,5	28,6	174,6	222,3	387,8	190,0	272,7	133,6	172,5
	133	330,2	RD30013	12825	6281	630,2	960,4	273,1	10 1/2 - 12	60,3	85,7	85,7	158,8	2 1/2-12 x 82,5	28,6	174,6	222,3	387,8	190,0	272,7	133,6	296,9
363	169	152,4	RD4006	7724	4051	489,7	642,1	320,7	12 1/2 - 8	69,9	97,6	184,2	184,2	3-12 x 92,2	31,8	198,4	254,0	506,6	240,3	356,2	169,0	265,6
	169	330,2	RD40013	16744	8790	667,5	997,7	320,7	12 1/2 - 8	69,9	97,6	184,2	184,2	3-12 x 92,2	31,8	198,4	254,0	506,6	240,3	356,2	169,0	349,6
454	222	152,4	RD5006	9774	4838	522,3	674,7	374,7	14 3/4 - 8	79,4	105,6	105,6	203,2	3 1/4-12 x 107,9	38,1	215,9	285,8	641,1	317,0	450,8	222,8	371,8
	222	330,2	RD50013	21189	10480	700,1	1030,3	374,7	14 3/4 - 8	79,4	105,6	105,6	203,2	3 1/4-12 x 107,9	38,1	215,9	285,8	641,1	317,0	450,8	222,8	495,8

\*UN Thread

Model Shown:  
**R2802C**



**Features**

**HIGH-TONNAGE, LOW CYCLE APPLICATION, GRAVITY RETURN.**

- Visible indicator band alerts when stroke limit is reached. Overflow port (weep hole) stroke limiter prevents piston from being overextended.
- Alloy heat treated piston and body for reliability and strength.
- Plated piston rod increases corrosion resistance and gives superior bearing support.
- Optional swivel load caps reduce the effects of off-center loading tilts up to 5 degrees. Radial grooves on top of cap reduce load slippage.

**Technical Dimensions**

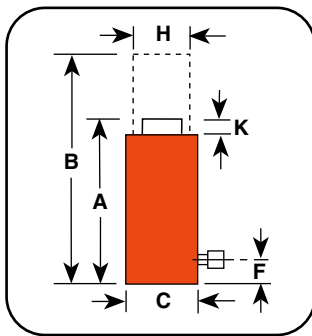

**Optional Swivel Load Caps Ordering Info**

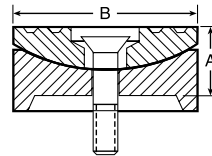

Cylinder Tonnage	Swivel Cap Order No.	Wt. (kg)	A (mm)	B (mm)
50-91	420466	.08	25,4	71,4
136-181	420867	4,0	38,1	130,2
254	420868	6,1	44,5	149,2
322	420869	16,8	69,9	195,3
390	420870	23,6	79,4	225,4
513	420871	35,4	92,1	250,8

Reduce the effects of off-center loading. Tilt up to 5 degrees. Radial grooves on top of cap reduce load slippage. Notch across face of each cap helps keep loads having a protruding or round shaped centered.

**Ordering Information**

Cyl. Cap. Metric Tons (kN)*	Stroke (mm)	Order No.	Oil Cap. (cm <sup>3</sup> )	A	B	C	F	H	K	Bore Dia. (mm)	Cylinder Effective Area (cm <sup>2</sup> )	Metric Tons at 700 (bar)	Prod. Wt. (kg)
				Retracted Height (mm)	Extended Height (mm)	Outside Dia. (mm)	Base to Port (mm)	Piston Rod Dia. (mm)	Piston Rod Protrusion (mm)				
50 (539)	50,8	R552C	362	125,4	176,2	127,0	25,4	95,3	3,2	95,3	71,2	50,1	12,3
	152,4	R556C	1087	227,0	379,4	127,0	25,4	95,3	3,2	95,3	71,2	50,1	22,7
	254,0	R5510C	1811	328,6	582,6	127,0	25,4	95,3	3,2	95,3	71,2	50,1	32,7
91 (981)	50,8	R1002C	677	139,7	190,5	165,1	25,4	130,2	3,2	130,2	133,1	93,6	23,6
	152,4	R1006C	2030	241,3	393,7	165,1	25,4	130,2	3,2	130,2	133,1	93,6	40,4
136 (1471)	50,8	R1502C	1007	161,9	212,7	204,8	31,8	158,8	3,2	158,8	197,9	139,1	41,8
	152,4	R1506C	3019	263,5	415,9	204,8	31,8	158,8	3,2	158,8	197,9	139,1	68,6
	254,0	R15010C	5032	365,1	619,1	204,8	31,8	158,8	3,2	158,8	197,9	139,1	95,3
181 (1961)	50,8	R2002C	1355	190,5	241,3	235,0	41,3	184,2	3,2	184,2	266,3	187,2	65,8
	152,4	R2006C	4062	292,1	444,5	235,0	41,3	184,2	3,2	184,2	266,3	187,2	100,3
254 (2746)	50,8	R2802C	1861	190,5	241,3	260,4	41,3	215,9	3,2	215,9	365,9	257,5	91,6
	152,4	R2806C	5583	292,1	444,5	276,2	41,3	215,9	3,2	215,9	365,9	257,5	136,7
322 (3579)	50,8	R3552C	2326	231,8	282,6	298,5	54,0	241,3	3,2	241,3	457,2	321,4	137,1
	152,4	R3556C	6975	333,4	485,8	298,5	54,0	241,3	3,2	241,3	457,2	321,4	197,0
	254,0	R35510C	11624	435,0	689,0	298,5	54,0	241,3	3,2	241,3	457,2	321,4	256,5
390 (4217)	50,8	R4302C	2841	263,5	314,3	330,2	63,5	266,7	3,2	266,7	558,5	392,7	199,8
	152,4	R4306C	18548	365,1	517,5	330,2	63,5	266,7	3,2	266,7	558,5	392,7	276,5
513 (5541)	50,8	R5652C	3710	292,1	342,9	377,8	69,9	304,8	3,2	304,8	729,5	512,9	289,7
	152,4	R5656C	11129	393,7	546,1	377,8	69,9	304,8	3,2	304,8	729,5	512,9	389,5
	254,0	R56510C	18548	495,3	749,3	377,8	69,9	304,8	3,2	304,8	729,5	512,9	489,4

Model Shown:

**R2806D, R1502D**



**Features**

**HIGH-TONNAGE, LOW CYCLE, HYDRAULIC RETURN CYLINDERS.**

- Cylinders come standard with swivel caps to reduce the effects of off-center loading.
- Cylinders may be “dead-ended” without damage.
- Hard chrome plated, heat treated piston rod reduces wear on piston and gland nut.
- Built-in safety relief valve prevents over-pressurization of the retraction circuit.
- Each cylinder has two 9796 3/8" NPTF female half couplers.

**Technical Dimensions**

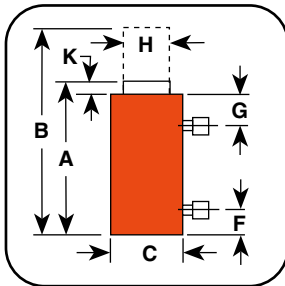

**Hydraulic Hoses**



Heavy-duty and thermo plastic hydraulic hoses to meet your requirements and safety factor.

Refer to the accessories section for details.

**Ordering Information**

Cyl. Cap. Metric Tons (kN)*	Stroke (mm)	Order No.	Oil Cap. (cm <sup>3</sup> )		A	B	C	F	G	H	K	Bore Dia. (mm)	Cylinder Effective Area (cm <sup>2</sup> )	Metric Tons at 700 (bar)	Prod. Wt. (kg)
					Retracted Height (mm)	Extended Height (mm)	Outside Dia. (mm)	Base to Port (mm)	Cylinder Top to Port (mm)	Piston Rod Dia. (mm)	Piston Rod Protrusion (mm)				
			Push	Return											
91 (981)	50,8	R1002D	675	315	168,7	219,5	165,1	25,4	55,9	95,3	7,1	130,3	132,9	93,4	24,5
	152,4	R1006D	2025	944	270,3	422,7	165,1	25,4	55,9	95,3	7,1	130,3	132,9	93,4	36,7
	254,0	R10010D	3376	1573	371,9	625,9	165,1	25,4	55,9	95,3	7,1	130,3	132,9	93,4	49,0
136 (1471)	50,8	R1502D	1006	485	189,0	239,8	204,7	31,8	57,2	114,3	7,6	158,8	198,1	139,1	43,1
	152,4	R1506D	3019	1455	290,6	443,0	204,7	31,8	57,2	114,3	7,6	158,8	198,1	139,1	61,7
181 (1961)	50,8	R2002D	1354	642	206,8	257,6	235,0	41,4	58,7	133,4	8,6	184,2	266,5	187,2	61,7
	152,4	R2006D	4061	1927	308,4	460,8	235,0	41,4	58,7	133,4	8,6	184,2	266,5	187,2	84,8
	254,0	R20010D	6768	3212	410,0	664,0	235,0	41,4	58,7	133,4	8,6	184,2	266,5	187,2	108,4
254 (2746)	50,8	R2802D	1858	773	233,7	284,5	276,4	47,8	65,5	165,1	10,4	215,9	365,8	257,3	99,3
	152,4	R2806D	5575	2320	335,3	487,7	276,4	47,8	65,5	165,1	10,4	215,9	365,8	257,3	134,7
	254,0	R28010D	9291	3867	436,9	690,9	276,4	47,8	65,5	165,1	10,4	215,9	365,8	257,3	170,6
322 (3579)	50,8	R3552D	2324	777	66,8	339,9	298,5	54,1	69,9	196,9	11,2	241,3	457,4	321,4	147,0
	152,4	R3556D	6971	2330	390,7	543,1	298,5	54,1	69,9	196,9	11,2	241,3	457,4	321,4	191,0
390 (4217)	50,8	R4302D	2838	977	312,7	363,5	330,2	63,5	74,9	215,9	11,9	266,7	558,7	392,7	199,1
	152,4	R4306D	8515	2930	414,3	566,7	330,2	63,5	74,9	215,9	11,9	266,7	558,7	392,7	253,1
	254,0	R43010D	14191	4883	515,9	769,9	330,2	63,5	74,9	215,9	11,9	266,7	558,7	392,7	305,3
513 (5541)	50,8	R5652D	3707	1259	345,2	396,0	378,0	69,9	81,3	247,7	14,0	304,8	729,7	512,9	280,8
	152,4	R5656D	11120	3776	446,8	599,2	378,0	69,9	81,3	247,7	14,0	304,8	729,7	512,9	350,2
	254,0	R56510D	18534	6293	548,4	802,4	378,0	69,9	81,3	247,7	14,0	304,8	729,7	512,9	420,0

Model Shown:  
**RGL552**



Note: When selecting a hydraulic cylinder(s) capacity and stroke, Power Team recommends that you size to the 80% Rule. This will ensure additional safety factor and extend the product performance over time.

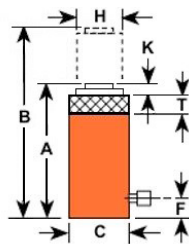

**Features**

- Positive mechanical locking collar safely supports load for extended periods of time with hydraulic pressure released.
- Patented swivel cap provides concentrated load centering up to 5 degrees.
- Sealing technology provides rod lubrication to reduce friction and wear.
- Robust retaining ring withstands full load end stop and conforms with ANSI B30.1 standards. Power-Tech nitro-carburization surface treatment inhibits corrosion and provides exceptional durability.
- Power-Tech nitro-carburization surface treatment inhibits corrosion and provides exceptional durability.

Base Mounting Holes					
Tonnage	# of Base Mounting Holes	Base Thread Size	Base Thread Depth (mm.)	Base Mounting Diameter (mm.)	Orientation
50	4	M12X1,75 - 6H	18,0	77,0	Mounting hole orientation is not maintained to port location
68	4	M12X1,75 - 6H	18,0	93,0	
91	4	M16x1,5 - 6H	15,7	101,6	
136	4	M16x1,5 - 6H	22,9	130,0	
181	4	M20X1,5 - 6H	30,5	145,3	

Four base mounting holes are 45° apart - standard on all models.

\*UN Thread

**Ordering Information**

Cyl. Cap. Metric Tons (kN)*	Stroke (mm)	Order No.	A	B	C	F	H	K	T	Bore Dia. (mm)	Cyl. Eff. Area (Adv.) (sq. cm)	Oil Cap. (cu. cm)	Internal Press at Cap. (bar)	Weight w/o Oil (kg)
			Ret. Height (mm)	Ext. Height (mm)	Out. Dia. (mm)	Base to Port (mm)	Piston Rod Dia. (mm)	Swivel Cap Protrusion (mm)	Nut Thickness (mm)					
50 (490)	50,8	RGL552	197,61	248,41	131,06	22,10	69,85	13,46	20,83	95,25	71,25	361,97	687	17,6
	101,6	RGL554	248,41	350,01	131,06	22,10	69,85	13,46	46,23	95,25	71,25	723,94	687	21,6
	152,4	RGL556	299,21	451,61	131,06	22,10	69,85	13,46	71,63	95,25	71,25	1085,91	687	25,5
	203,2	RGL558	350,01	553,21	131,06	22,10	69,85	13,46	97,03	95,25	71,25	1447,87	687	29,5
	254	RGL5510	400,81	654,81	131,06	22,10	69,85	13,46	122,43	95,25	71,25	1809,84	687	33,5
	304,8	RGL5512	451,61	756,41	131,06	22,10	69,85	13,46	147,83	95,25	71,25	2171,81	687	37,4
68 (667)	50,8	RGL752	208,79	259,59	146,81	22,86	79,38	14,22	24,89	111,13	96,98	492,68	688	23,3
	101,6	RGL754	259,59	361,19	146,81	22,86	79,38	14,22	50,29	111,13	96,98	985,36	688	28,0
	152,4	RGL756	310,39	462,79	146,81	22,86	79,38	14,22	75,69	111,13	96,98	1478,04	688	32,7
	203,2	RGL758	361,19	564,39	146,81	22,86	79,38	14,22	101,09	111,13	96,98	1970,72	688	37,5
	254	RGL7510	411,99	665,99	146,81	22,86	79,38	14,22	126,49	111,13	96,98	2463,40	688	42,3
	304,8	RGL7512	462,79	767,59	146,81	22,86	79,38	14,22	151,89	111,13	96,98	2956,08	688	47,0
91 (892)	50,8	RGL1002	220,73	271,53	165,86	23,88	95,25	18,80	27,43	130,18	133,09	676,08	668	30,9
	101,6	RGL1004	271,53	373,13	165,86	23,88	95,25	18,80	52,83	130,18	133,09	1352,15	668	37,0
	152,4	RGL1006	322,33	474,73	165,86	23,88	95,25	18,80	78,23	130,18	133,09	2028,23	668	43,0
	203,2	RGL1008	373,13	576,33	165,86	23,88	95,25	18,80	103,63	130,18	133,09	2704,31	668	48,9
	254	RGL10010	423,93	677,93	165,86	23,88	95,25	18,80	129,03	130,18	133,09	3380,38	668	54,9
	304,8	RGL10012	474,73	779,53	165,86	23,88	95,25	18,80	154,43	130,18	133,09	4056,46	668	60,9
136 (1334)	50,8	RGL1502	243,84	294,64	196,85	31,24	114,30	18,29	34,04	158,75	197,93	1005,47	674	48,8
	101,6	RGL1504	294,64	396,24	196,85	31,24	114,30	18,29	59,44	158,75	197,93	2010,94	674	56,9
	152,4	RGL1506	345,44	497,84	196,85	31,24	114,30	18,29	84,84	158,75	197,93	3016,40	674	65,0
	203,2	RGL1508	396,24	599,44	196,85	31,24	114,30	18,29	110,24	158,75	197,93	4021,87	674	73,2
	254	RGL15010	447,04	701,04	196,85	31,24	114,30	18,29	135,64	158,75	197,93	5027,34	674	81,4
	304,8	RGL15012	497,84	802,64	196,85	31,24	114,30	18,29	161,04	158,75	197,93	6032,81	674	89,5
181 (1775)	50,8	RGL2002	268,99	319,79	228,60	37,85	133,35	21,34	38,61	184,15	266,33	1352,96	668	73,2
	101,6	RGL2004	319,79	421,39	228,60	37,85	133,35	21,34	64,01	184,15	266,33	2705,91	668	84,3
	152,4	RGL2006	370,59	522,99	228,60	37,85	133,35	21,34	89,41	184,15	266,33	4058,87	668	95,4
	203,2	RGL2008	421,39	624,59	228,60	37,85	133,35	21,34	114,81	184,15	266,33	5411,83	668	106,5
	254	RGL20010	472,19	726,19	228,60	37,85	133,35	21,34	140,21	184,15	266,33	6764,79	668	117,6
	304,8	RGL20012	522,99	827,79	228,60	37,85	133,35	21,34	165,61	184,15	266,33	8117,74	668	128,7

Models Shown:



RGL2506



RGL60010

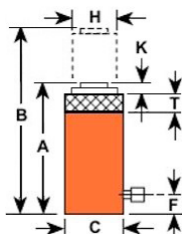

Note: When selecting a hydraulic cylinder(s) capacity and stroke, Power Team recommends that you size to the 80% Rule. This will ensure additional safety factor and extend the product performance over time.

**Features**

- Positive mechanical locking collar safely supports load for extended periods of time with hydraulic pressure released.
- Patented swivel cap provides concentrated load centering up to 5 degrees.
- Sealing technology provides rod lubrication to reduce friction and wear.
- Optimized piston glad design resists side loading conditions corrosion and provides exceptional durability.
- Robust retaining ring withstands full load end stop and conforms with ANSI B30.1 standards.
- Power-Tech nitro-carburization surface treatment inhibits corrosion and provides exceptional durability.
- Base mounting holes standard on all models (they are not maintained to port location.)

Base Mounting Holes					
Tonnage	# of Base Mounting Holes	Base Thread Size	Base Thread Depth	Base Mounting Diameter	Orientation
			(mm.)	(mm.)	
227	4	M24X3,0 - 6H	37,0	153,9	Mounting hole orientation is not maintained to port location
272	4	M24X3,0 - 6H	37,0	179,3	
363	4	M30x3,5 - 6H	45,7	194,3	
454	4	M30x3,5 - 6H	38,1	227,3	
544	4	M33X2,0 - 6H	49,5	245,1	



Four base mounting holes are 45° apart - standard on all models.

\*UN Thread

**Ordering Information**

Cyl. Cap. Metric Tons (kN)*	Stroke (mm)	Order No.	A	B	C	F	H	K	T	Bore Dia. (mm)	Cyl. Eff. Area (Adv.) (sq. cm)	Oil Cap. (cu. cm)	Internal Press at Cap. (bar)	Weight w/o Oil (kg)
			Ret. Height (mm)	Ext. Height (mm)	Out. Dia. (mm)	Base to Port (mm)	Piston Rod Dia. (mm)	Swivel Cap Protrusion (mm)	Nut Thickness (mm)					
227 (2226)	50,8	RGL2502	298,20	349,00	256,54	59,69	152,40	22,86	42,16	203,20	324,28	686	107,7	1647,36
	101,6	RGL2504	349,00	450,60	256,54	59,69	152,40	22,86	42,16	203,20	324,28	686	122,4	3294,72
	152,4	RGL2506	399,80	552,20	256,54	59,69	152,40	22,86	42,16	203,20	324,28	686	137,1	4942,08
	203,2	RGL2508	450,60	653,80	256,54	59,69	152,40	22,86	42,16	203,20	324,28	686	151,8	6589,43
	254	RGL25010	501,40	755,40	256,54	59,69	152,40	22,86	42,16	203,20	324,28	686	166,6	8236,79
	304,8	RGL25012	552,20	857,00	256,54	59,69	152,40	22,86	42,16	203,20	324,28	686	181,3	9884,15
272 (2667)	50,8	RGL3002	349,00	399,80	289,56	62,99	165,10	26,42	82,30	228,60	410,42	650	161,8	2084,94
	101,6	RGL3004	399,80	501,40	289,56	62,99	165,10	26,42	82,30	228,60	410,42	650	180,0	4169,88
	152,4	RGL3006	450,60	603,00	289,56	62,99	165,10	26,42	82,30	228,60	410,42	650	198,2	6254,81
	203,2	RGL3008	501,40	704,60	289,56	62,99	165,10	26,42	82,30	228,60	410,42	650	216,4	8339,75
	254	RGL30010	552,20	806,20	289,56	62,99	165,10	26,42	82,30	228,60	410,42	650	234,6	10424,69
	304,8	RGL30012	603,00	907,80	289,56	62,99	165,10	26,42	82,30	228,60	410,42	650	252,7	12509,63
363 (3560)	50,8	RGL4002	396,75	447,55	337,82	70,36	190,50	30,48	96,52	266,73	558,73	637	253,7	2838,37
	101,6	RGL4004	447,55	549,15	337,82	70,36	190,50	30,48	96,52	266,73	558,73	637	278,2	5676,75
	152,4	RGL4006	498,35	650,75	337,82	70,36	190,50	30,48	96,52	266,73	558,73	637	302,8	8515,12
	203,2	RGL4008	549,15	752,35	337,82	70,36	190,50	30,48	96,52	266,73	558,73	637	327,3	11353,49
	254	RGL40010	599,95	853,95	337,82	70,36	190,50	30,48	96,52	266,73	558,73	637	351,9	14191,86
	304,8	RGL40012	650,75	955,55	337,82	70,36	190,50	30,48	96,52	266,73	558,73	637	376,4	17030,24
454 (4452)	50,8	RGL5002	414,02	464,82	374,65	73,66	203,20	33,27	108,20	292,10	670,10	664	324,3	3404,11
	101,6	RGL5004	464,82	566,42	374,65	73,66	203,20	33,27	108,20	292,10	670,10	664	354,2	6808,22
	152,4	RGL5006	515,62	668,02	374,65	73,66	203,20	33,27	108,20	292,10	670,10	664	384,0	10212,33
	203,2	RGL5008	566,42	769,62	374,65	73,66	203,20	33,27	108,20	292,10	670,10	664	413,9	13616,45
	254	RGL50010	617,22	871,22	374,65	73,66	203,20	33,27	108,20	292,10	670,10	664	443,7	17020,56
	304,8	RGL50012	668,02	972,82	374,65	73,66	203,20	33,27	108,20	292,10	670,10	664	473,6	20424,67
544 (5335)	50,8	RGL6002	432,05	482,85	406,40	76,71	228,60	36,07	113,28	317,50	791,71	674	389,4	4021,87
	101,6	RGL6004	482,85	584,45	406,40	76,71	228,60	36,07	113,28	317,50	791,71	674	425,6	8043,74
	152,4	RGL6006	533,65	686,05	406,40	76,71	228,60	36,07	113,28	317,50	791,71	674	461,7	12065,61
	203,2	RGL6008	584,45	787,65	406,40	76,71	228,60	36,07	113,28	317,50	791,71	674	497,9	16087,48
	254	RGL60010	635,25	889,25	406,40	76,71	228,60	36,07	113,28	317,50	791,71	674	534,1	20109,36
	304,8	RGL60012	686,05	990,85	406,40	76,71	228,60	36,07	113,28	317,50	791,71	674	570,2	24131,23

Model Shown:

**RA1006L, RA556L**



**Features**

**POSITIVE MECHANICAL LOCKING COLLAR TO SUPPORT EXTENDED LOAD HOLDING.**

- Supports lifted load for extended periods of time with hydraulic pressure released.
- At half the weight of steel cylinders of comparable capacity, aluminum cylinders are ideal when portability is a key factor.
- Features carrying handle.
- Complies with ANSI / ASME B30.1 safety standards.



**Locking Collar**



Locking collar feature permits non-hydraulic support of load.

**Technical Dimensions**

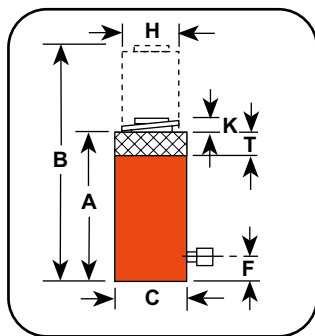

**Learn More - About Hydraulic Safety Insight**



Looking for great safety suggestions? Visit our Resource Section to get a better understanding of hydraulic and mechanical safety insights on what to look for when working around hydraulics.

**Ordering Information**

Cyl. Cap.	Stroke	Order No.	Oil Cap.	A	B	C	F	H	K	T	Bore Dia.	Cylinder Effective Area	Metric Tons at 700	Prod. Wt.
				Retracted Height	Extended Height	Outside Dia.	Base to Port	Piston Rod Dia.	Piston Rod Protrusion	Nut Thickness				
Metric Tons (kN)*	(mm)		(cm <sup>3</sup> )	(mm)	(mm)	(mm)	(mm)	(mm)	(mm)	(mm)	(mm)	(cm <sup>2</sup> )	(bar)	(kg)
50 (539)	155,5	RA556L	1109	317,5	473,1	133,4	34,9	82,6	12,7	38,1	95,3	71,2	50,1	13,4
91 (981)	158,8	RA1006L	2116	339,7	498,5	187,3	30,2	114,3	6,4	38,1	130,2	133,0	93,5	29,0

Model Shown:  
**R556L**



**Features**

**POSITIVE MECHANICAL LOCKING COLLAR TO SUPPORT LOAD.**

- Supports lifted load for extended periods of time with hydraulic pressure released.
- Visible indicator band alerts when stroke limit is reached. Overflow port (“weep hole”) stroke limiter prevents piston from being overextended.
- All cylinders feature coated pistons to resist corrosion and abrasion.
- Complies with ANSI / ASME B30.1 safety standards.

**Technical Dimensions**

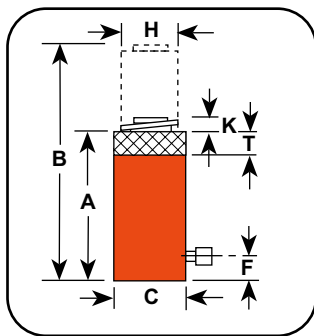

**Ordering Information**

Cyl. Cap. Metric Tons (kN)*	Stroke (mm)	Order No.	Oil Cap. (cm³)	A	B	C	F	K	L	T	Bore Dia. (mm)	Cylinder Effective Area (cm²)	Metric Tons at 700 (bar)	Prod. Wt. (kg)
				Retracted Height (mm)	Extended Height (mm)	Outside Dia. (mm)	Base to Port (mm)	Piston Rod Dia. (mm)	Piston Rod Protrusion (mm)	Nut Thickness (mm)				
50 (539)	50,8	R552L	362	161,9	212,7	125,4	25,4	95,3	3,2	36,5	95,3	71,2	50,1	15,3
	152,4	R556L	1087	263,5	415,9	125,4	25,4	95,3	3,2	36,5	95,3	71,2	50,1	26,3
	254,0	R5510L	1811	365,1	619,1	125,4	25,4	95,3	3,2	36,5	95,3	71,2	50,1	36,3
91 (981)	50,8	R1002L	677	184,2	235,0	165,1	25,4	130,2	3,2	44,5	130,2	133,1	93,4	30,0
	152,4	R1006L	2030	285,8	438,2	165,1	25,4	130,2	3,2	44,5	130,2	133,1	93,4	46,8
	254,0	R10010L	3383	387,4	641,4	165,1	25,4	130,2	3,2	44,5	130,2	133,1	93,4	64,5
136 (1471)	50,8	R1502L	1007	206,4	257,2	204,8	31,8	158,8	3,2	44,5	158,8	197,9	139,1	53,0
	152,4	R1506L	3019	308,0	460,4	204,8	31,8	158,8	3,2	44,5	158,8	197,9	139,1	80,4
	254,0	R15010L	5027	409,7	663,7	204,7	31,8	158,8	3,2	44,5	158,8	197,9	153,4	106,6
181 (1932)	50,8	R2002L	1355	241,3	292,1	235,0	41,3	184,2	3,2	50,8	184,2	266,3	187,2	83,1
	152,4	R2006L	4062	342,9	495,3	235,0	41,3	184,2	3,2	50,8	184,2	266,3	187,2	117,6
	203,2	R2008L	3303	393,7	596,9	234,6	41,4	184,2	3,2	50,8	184,2	266,3	206,4	102,2
254 (2746)	50,8	R2802L	1861	247,7	298,5	276,2	41,3	215,9	3,2	57,2	215,9	366,0	257,3	118,5
	152,4	R2806L	5583	349,3	501,7	276,2	41,3	215,9	3,2	57,2	215,9	366,0	257,3	163,0
	254,0	R28010L	9305	450,9	704,9	276,2	41,3	215,9	3,2	57,2	215,9	366,0	257,3	208,1
322 (3482)	50,8	R3552L	2326	292,1	342,9	298,5	54,0	241,3	3,2	60,3	241,3	457,2	321,4	173
	152,4	R3556L	6975	393,7	546,1	298,5	54,0	241,3	3,2	60,3	241,3	457,2	321,4	232,5
390 (4217)	50,8	R4302L	2841	333,4	384,2	330,2	63,5	266,7	3,2	69,9	266,7	558,5	392,7	252,4
	152,4	R4306L	9520	435,0	587,4	330,2	63,5	266,7	3,2	69,9	266,7	558,5	392,7	329,2
	254,0	R43010L	14201	536,6	790,6	330,2	63,5	266,7	3,2	69,9	266,7	558,5	392,7	405,9
513 (5541)	50,8	R5652L	371	371,2	422,3	377,8	69,9	304,8	3,2	79,4	304,8	729,5	512,9	368,2
	152,4	R5656L	11129	473,1	625,5	377,8	69,9	304,8	3,2	79,4	304,8	729,5	512,9	468,0
	254,0	R56510L	18548	574,7	828,7	377,8	69,9	304,8	3,2	79,4	304,8	729,5	512,9	568,0

**Optional Swivel Load Caps Ordering Info**

Cylinder Tonnage	Swivel Cap Order No.	Wt. (kg)	A (mm)	B (mm)
50-91	420866	0,8	25,4	71,4
136-181	420867	4,8	38,1	130,2
254	420868	6,1	44,5	149,2
322	420869	16,8	69,9	195,3
390	420870	23,6	79,4	225,4
513	420871	35,4	92,1	250,8

Reduce the effects of off-center loading. Tilt up to 5 degrees. Radial grooves on top of cap reduce load slippage. Notch across face of each cap helps keep loads having a round shaped centered.

NOTE: Supported loads not to exceed the rated capacity of the cylinders. Not intended to support additional dynamic loads, such as those applied by moving vehicles.

Model Shown:  
**RGP5652, RGP2202**



**Features**

- The Mechanical locking collar safely supports loads for an extended period of time removing the chance of a hydraulic leak down causing a load shift.
- The Patented 5 degree deep swivel cap concentrates loads to minimize offset conditions.
- Compact design is ideal for confined areas
- Buttress thread design supports locking collar strength and security along with time saving quick run-down
- *Power-Tech* nitro-carburization surface treatment inhibits corrosion and provides exceptional durability
- Weep hole provides visual indication of piston over travel
- One high flow 3/8" NPTF female half coupler and carry eyelets are included

**Technical Dimensions**

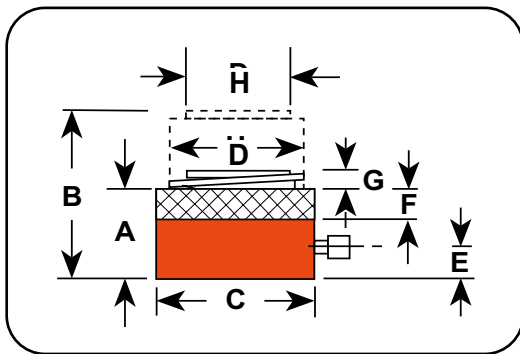

Pancake locking cylinders are ideal for tight quartered locations.



**Ordering Information**

Cyl. Cap. Metric Tons (kN)*	Stroke (MM)	Order No.	A	B	C	D	E	F	G	H	Cyl. Eff. Area (Adv.) (SQ. CM)	Oil Cap. (CU. CM)	Internal Press At Cap. (BAR)	Wt. W/O Oil (KG)	Weight w/o Oil (lbs.)
			Ret. Height (MM)	Ext. Height (MM)	Outside Dia. (MM)	Bore Dia. (MM)	Base To Port (MM)	Nut Thick. (MM)	Swvl Cap Protusion (MM)	Swvl Cap Dia. (MM)					
61 (589)	44,45	RGP672	121,41	165,86	147,32	104,78	21,84	22,23	0,69	70,61	86,22	383,23	691	15,2	33,5
100 (981)	44,45	RGP1102	132,33	176,78	177,80	136,53	22,53	28,58	1,07	98,30	146,39	650,69	669	23,7	52,3
163 (1589)	44,45	RGP1802	147,83	192,28	228,60	171,45	26,67	34,93	2,51	117,60	230,86	1,026,18	694	44,1	97,2
200 (1964)	44,45	RGP2202	156,72	201,17	254,00	190,50	28,19	40,64	2,46	136,40	285,01	1,266,89	687	57,7	127,2
254 (2481)	44,45	RGP2802	159,26	203,71	279,40	215,90	30,48	41,91	2,44	141,22	366,09	1,627,25	680	70,4	155,2
390 (3825)	44,45	RGP4302	177,80	222,25	355,60	266,70	39,37	47,63	2,64	169,16	558,63	2,483,10	685	128,1	282,5
513 (5031)	44,45	RGP5652	193,04	237,49	406,40	304,80	46,74	53,34	6,30	197,36	729,64	3,243,24	689	180,8	398,7



**ZCC500-6**

**Features**

- Cylinder equipped with integral retainer ring and may be “dead-headed” without damage.
- Hardened Integral Swivel Cap to reduce the effects of off-center loading.
- Piston wiper to keep dirt, water and other contaminants out of the internal bearing and bore surfaces.
- Plated piston resists corrosion and abrasion.
- Base mounting holes are standard.
- Each cylinder has one 3/8" NPTF female half coupler.
- Maximum operating pressure 10,000 psi (700 bar).

**Features**

- Available with integrated hardened flat load cap, or optional swivel cap.
- Piston wiper to keep dirt, water and other contaminants out of the internal bearing and bore surfaces.
- Double-acting for fast and positive retraction.
- Cylinder may be “dead-headed” without damage.
- Plated piston resists corrosion and abrasion.
- Built-in safety relief valve prevents over-pressurization of the retraction circuit.
- Each cylinder has two 3/8" NPTF female half couplers.
- Maximum operating pressure 10,000 psi (700 bar).



**ZDD1000-6**

**Features**

- Hardened Integral Swivel Cap to reduce the effects of off-center loading.
- Locking Collar supports load mechanically for extended periods of time with hydraulic pressure released.
- Equipped with overflow port stroke limiter to prevent piston from being overextended.
- Special coating provides corrosion resistance and low friction for smoother operation.
- Each cylinder has one 3/8" NPTF female half coupler.
- Maximum operating pressure 10,000 psi (700 bar).



**ZCL500-8**

**For more information on the Z Series Cylinders, please contact Customer Service/Technical Support.**

# PUMPS

## MARKET LEADING HIGH PRESSURE POWER UNITS FOR A WIDE ARRAY OF APPLICATIONS AND USES.

Every power unit goes through a rigorous assembly and test process to ensure the highest level of performance:

- Power units are available in manual or powered configurations. Powered options include electric, air, and gas.
- A wide array of reservoir sizes from under 0,99 l to 152 l
- Variety of valve configurations, such as dump, 2-way, 3-way and 4-way in manual and solenoid configurations,
- Whether you are seeking a manual, electrical or an air power pump, Power Team pumps can generate flows up to 420 cm<sup>3</sup> / minute @ 700 Bar.



Powerthon  
Limited  
**Lifetime**  
WARRANTY  
ISO 9001 Certified

Worry-Free  
Ownership



Section / Series	Power Source	Flow Stages	Flow @ Max Pressure	Page(s)
Introduction	All	All	All	45-48
P	Manual	Single & Two-Speed	197-901 cu. cm.	49
RPS	Manual	Single & Two-Speed	—	51
PA6	Air	Single-Acting	1721 cu. cm.	53
PA6D	Air	Single-Speed	98 cu. cm.	55
PA9	Air	Single-Speed	147 cu. cm.	57
PA60	Air	Two-Speed	98 cu. cm.	59
PA50	Air	Single-Speed	459 cu. cm.	61
PA17	Air	Two-Speed	279 cu. cm.	63
PA46/PA55	Air	Two-Speed	754-901 cu. cm.	65
PB43	Battery	Two-Speed	705 cu. cm.	67
PB10	Battery	Two-Speed	164 cu. cm.	69
PE10	Electric	Two-Speed	164 cu. cm.	73
PE17	Electric	Two-Speed	279 cu. cm.	75
PE18	Electric	Two-Speed	295 cu. cm.	77
PE21	Electric	Two-Speed	361 cu. cm.	79
PED	Electric	Two-Speed	410 cu. cm.	81
PE30	Electric	Two-Speed	492 cu. cm.	83
PE46	Electric	Two-Speed	754 cu. cm.	85
PE55	Electric	Two-Speed	901 cu. cm.	87
PE60	Electric	Two-Speed	918 cu. cm.	89
PQ60	Electric	Two-Speed	983 cu. cm.	91
PQ120	Electric	Two-Speed	1966 cu. cm.	93
PE400	Electric	Two-Speed	6883 cu. cm.	95
PE-NUT	Electric	Two-Speed	492 cu. cm.	97
PG120_CP	Gas	Two-Speed	2130 cu. cm.	98
PG30/55	Gas	Two-Speed	492-901 cu. cm.	99
PG120-PG400	Gas	Two-Speed	2130-6883 cu. cm.	101
eSync	Elec, Battery	—	—	103
MCS	Electric	—	1966-6883 cu. cm.	105
ATO	Air, Elec., Gas	Custom Built	—	107



## SELECTING THE RIGHT PUMP:

**Step 1** Select the hydraulic pump that best suits the application.

**Step 2** Select the series of pump with adequate oil output and reservoir capacity to power tool.

**Step 3** Select pump within series with the valve option that is best suited to the tool and application.

## PUMP SIZING CONSIDERATIONS:

1. What maximum system operating pressure (bar) is required?
2. What volume of oil delivery is required? (For manual pumps, cm<sup>3</sup> of oil per handle stroke. For powered pumps, cm<sup>3</sup>/min. of oil).
3. Is a single or two-speed pump required? (Two-speed pumps deliver high oil volume at low pressure for rapid cylinder piston advance, then shift to high pressure, low volume stage under load).
4. What is the preferred source of power?
  - a. Manual (hand or foot operated): Provides portability, can be used where electricity or shop air are not available.
  - b. Air/Hydraulic: Uses shop air or a portable air compressor.
  - c. Electric/Hydraulic: What voltage is available? Is a battery operated pump preferred?
  - d. Gasoline Engine/Hydraulic: Powers high-output pumps at remote job sites where air or electricity are unavailable.
5. Is portability of the pump a factor to consider?
6. Will the pump be used intermittently, or will it need to provide high-cycle operation? Does the application require that the pump be capable of starting under load?
7. Is fluid heat build-up a factor in your application? High-cycle applications may require a larger capacity oil reservoir for cooling.
8. Will the application require large displacement or multiple cylinders? Reservoir size and pump output levels will be factors to consider.
9. Does the working environment require a pump having a low operating noise (dBA) level?
10. Must the pump operate in a spark-free environment?
11. Do you need CE mark?



▶ **Manually-operated hydraulic pumps:**



- **P12, P23, P55** – These single-speed pumps are for use with single-acting cylinders.
- **P19/P19L, P59/P59L, P59F, P157, P159, P300, P460** – These two-speed pumps are used with single-acting cylinders. The two-speed feature provides high oil volume for fast cylinder piston approach to the work, then the pump automatically shifts to the high pressure stage. This reduces the number of pump handle strokes required.
- **P157D, P159D, P300D, P460D** – These two-speed pumps are used with double-acting cylinders.

▶ **Air / hydraulic pumps:**

Used where air is the preferred energy source or where electricity is not available. Ideal for use in petrochemical, mining or other flammable or explosive environments.



- **PA6 Series** – These single-speed pumps drive single or double-acting cylinders.
- **PA9 Series** – These new single-speed pumps drive single-acting cylinders and are ideal for powering portable hydraulic tools.
- **PA50 Series** – These single-speed pumps drive single or double-acting low pressure (221 bar) cylinders.
- **PA60** – This two-speed pump is equipped with a manifold to operate multiple cylinders, and provides a 7.6 l reservoir.
- **PA64** – Similar to PA60, this two-speed pump drives single or double-acting cylinders.
- **PA172 and PA174** – These “economy” two-speed pumps drive single or double-acting cylinders, depending on the model chosen. Provide a low weight-to-output ratio.
- **PA462 and PA464 Series** – These two-speed pumps drive single or double-acting cylinders, depending on the model selected. They offer high speed cylinder piston advance.
- **PA554** – This two-speed pump drives single or double-acting cylinders, delivering a high volume of oil.

▶ **Electric / Hydraulic pumps:**

All of the following pumps are two-speed models, and can be used to drive single or double-acting cylinders.



- **PE/PB10 Series “Quarter Horse” Series** – These pumps feature a 1/4 hp electric motor. A battery-powered version is available. Having a low noise level and weighing just 9,1 kg. They are ideal for powering portable hydraulic spreaders, nut splitters, pipe flange spreaders and other tools.
- **PE17 Series** – CSA rated for intermittent duty, these feature a 1/2 hp, single-phase induction motor with a low noise level (67-81 dBA). Smaller generators and low amperage circuits can be used as a power source.
- **PE46 Series** – Powered by a 1-1/2 hp, single-phase induction motor, operates at a moderate noise level of 77-81 dBA. CSA rated for intermittent duty.
- **PE18 Series** – CSA rated for intermittent duty, these feature a 1/2 hp, single-phase universal motor with a noise level of 85-90 dBA. Provide high-performance at a low price. Has low amperage draw.
- **PE30 Series** – Equipped with a 1 hp, single-phase permanent magnet motor, have a noise level of only 82-87 dBA. CSA rated for intermittent duty, and requires a relatively low voltage. Ideal for use in general construction applications. Roll cage/handle protects the motor and controls.
- **PE55 and PED25 Series** – Equipped with a 1-1/8 hp, single-phase universal motor, have a 90-95 dBA noise level. Offer the best weight to performance ratio of any Power Team electric/hydraulic pump. CSA rated for intermittent duty. The PED25 versions are “dual flow” pumps which deliver the same low and high pressures to both valves, and have a noise level of 80-85 dBA. They have a 1-1/2 hp induction motor.



► **Electric / Hydraulic pumps: (CONT.)**



- **PE60 Series** – These Vanguard® Supreme® pumps provide trouble-free service in the most severe working environments. Powered by a 1-1/8 hp, single-phase motor, has a moderate noise level of 80-85 dBA. Starts under load even at the reduced voltages encountered on construction sites. High-output pumps, ideal for use with post-tensioning/pre-stressing jacks and other high-pressure hydraulic tools.
- **“Custom-Built” Pumps** – Power Team offers you “assemble to order” electric/hydraulic pumps to suit unique applications. You can choose from pre-engineered, off-the-shelf components to customize your pump.
- **PE21 Series** – Ideal for heavy-duty, extended-cycle applications. Powered by a 1 hp, single-phase motor, pump operates at a very low noise level of 70 dBA. Pump automatically shuts down in the event of a power failure. CSA rated for intermittent duty.
- **“Quiet” Pumps** – Our PQ60 and PQ120 series operate at a very low noise level of between 73-78 dBA. The PQ60 has a 2 hp (single-phase) motor; the PQ120 has a 3 hp (three-phase) motor. These pumps are designed for heavy-duty, extended cycle operations. CSA rated for intermittent duty.
- **PE400 Series** – High-flow units deliver a large volume of high pressure oil for heavy construction and maintenance operations employing high tonnage cylinders. The PE400 is powered by a 10 hp, three-phase motor. Low noise rating of 73-80 dBA.

► **Gasoline-driven hydraulic pumps:**

These two-speed pumps are ideal for use in remote applications, such as construction sites. May be used with single or double-acting cylinders.



- **PG30 Series** – Powered by a 2-cycle, 2 hp Honda engine, these have an integral, protective “roll cage” and adequate reservoir capacity for cylinders up to 100 tons capacity or more. Readily portable, and popular in the railroad, rescue and construction markets.
- **PG55 Series** – With a 4-cycle, 4 hp Briggs & Stratton engine, this pump is based on our popular Vanguard® Series hydraulic system. It has a generous 19 l reservoir capacity.
- **PG120 Series** – Powered by a 4-cycle, 5.5 hp Honda engine. Has a 19 l reservoir, and is capable of handling multiple-cylinder lifting tasks. Ideal for the structure moving, pier setting, bridge lifting and concrete contracting industries.
- **PG4004** – Featuring a 4-cycle, 18 hp Honda engine, this unit has a big 75,7 l reservoir. Rugged steel “roll cage” has a hook on top and swivel casters for ease of mobility. Popular for concrete stressing applications.



**HYDRAULIC  
PUMP  
OPTIONS**

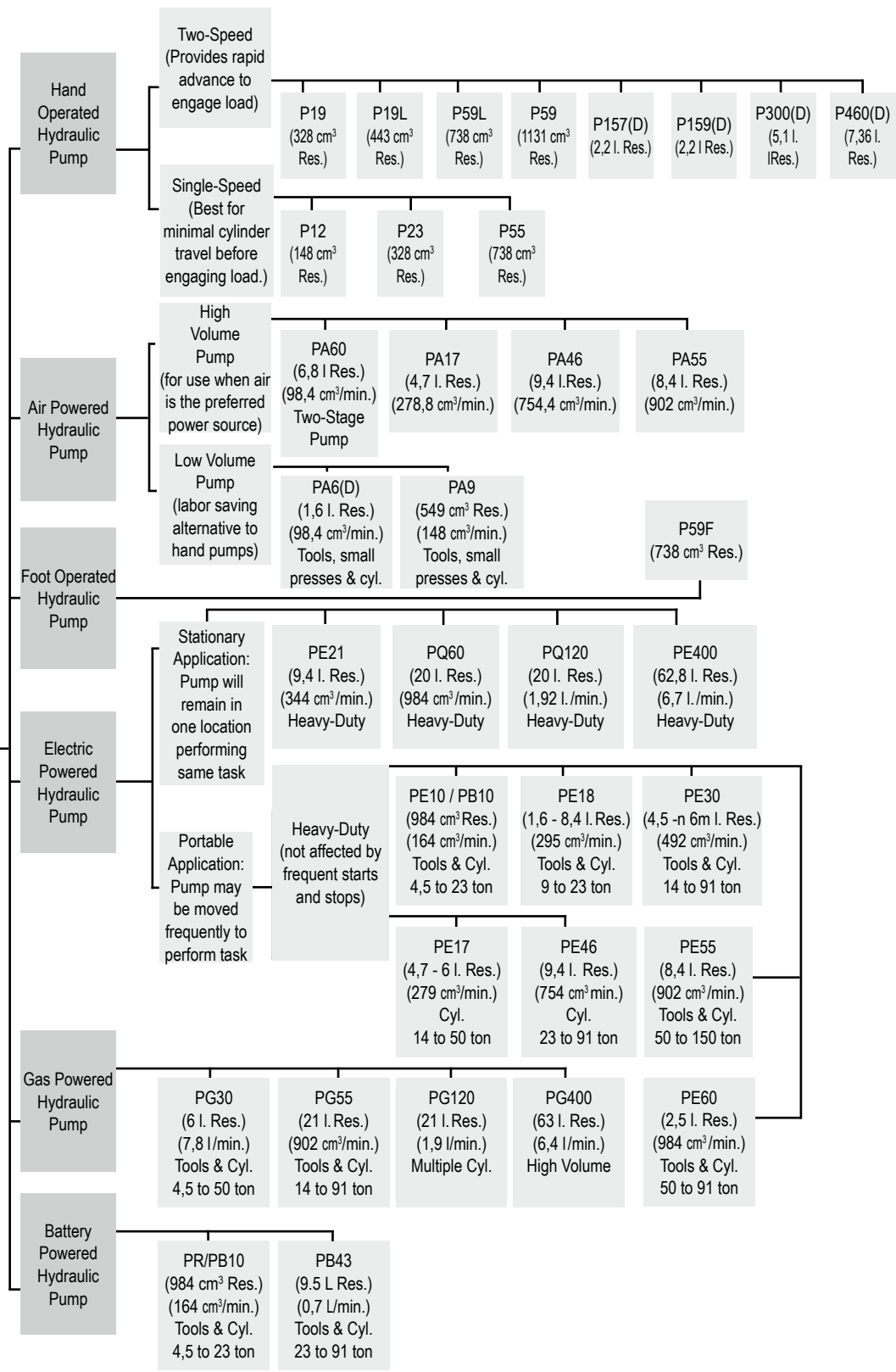

Model Shown:  
**P55, P12, P23**



Pumps

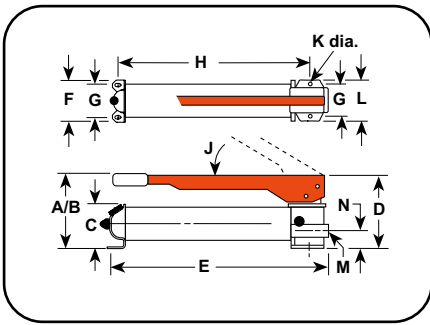

**Features**

**STEEL HAND PUMPS BEST SUITED FOR MRO APPLICATIONS.**

- All metal construction won't burn through in welding environments.
- Formed metal handle provides rigidity, and reduces operator fatigue with grip.
- Convenient fill port enables pumps to be filled in a horizontal or vertical position, excluding P12.
- Fill cap seal acts as safety valve preventing over-pressurizing of reservoir.
- Large valve knob gives added control for slowly metering loads down.



**Pump Protection System**

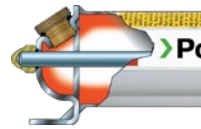

Power Team hand pumps, with the angled fill port, have a built in "relief valve" protection system. This system is designed to protect over-pressurization of the reservoir from sudden back pressure. This system also works as a seal to prevent oil leaks only fill to bottom of threads.



**Foot Pump Conversion Kit**



For Use With:	Kit Order No.	Wt. (kg)
P55, P59	FK59	2,7

**Technical Dimensions**

Order No.	A (mm)	B (mm)	C (mm)	D (mm)	E (mm)	F (mm)	G (mm)	H (mm)	J (deg.)	K (mm)	L (mm)	M (in.)	N (mm)
P12	101,6	330,2	60,0	101,6	342,9	85,7	55,6	292,1	45°	4,8	85,7	3/8 NPTF	28,6
P19	139,7	371,5	73,0	115,9	347,7	101,6	82,6	281,0	53°	7,9	101,6	3/8 NPTF	35,7
P23*	158,8	330,2	88,9	141,3	346,1	108,0	82,6	261,6	38°	7,9	120,7	3/8 NPTF	41,3
P55	165,1	533,4	88,9	141,3	584,2	108,0	82,6	501,7	38°	7,9	120,7	3/8 NPTF	41,3
P59	177,8	533,4	88,9	127,0	584,2	108,0	82,6	501,7	38°	7,9	120,7	3/8 NPTF	41,3
P59F	88,9	425,5	88,9	152,4	590,6	108,0	82,6	514,4	—	7,9	114,3	3/8 NPTF	42,9

\*The P23 pump maximum pressure is 210 bar only.

**Ordering Information**

For Use With	Speed	Order No.	Volume per Stroke		Max. Pressure		Handle Effort (kg)	Reservoir		Oil Port (cm)	Prod. Wt. (kg)
			LP (cm <sup>3</sup> )	HP (cm <sup>3</sup> )	LP (bar)	HP (bar)		Oil Cap. (cm <sup>3</sup> )	Usable Oil Cap. (cm <sup>3</sup> )		
Single-Acting Cylinders	1	P12	—	1,1	—	700	34	197	148	3/8 NPTF	2,6
	2	P19	5,0	1,2	22	700	45	400	328	3/8 NPTF	3,0
	1	P23	—	2,6	—	210	32	390	333	3/8 NPTF	5,5
	1	P55	—	2,6	—	700	66	902	738	3/8 NPTF	7,2
	2	P59	10,9	2,6	22	700	66	902	738	3/8 NPTF	7,8
	2	P59F	9,0	2,1	22	700	55	902	738	3/8 NPTF	6,4

LP = Low Pressure - HP = High Pressure

Model Shown:

**P19L, P59L, P59L-1500, P59L-1500G**

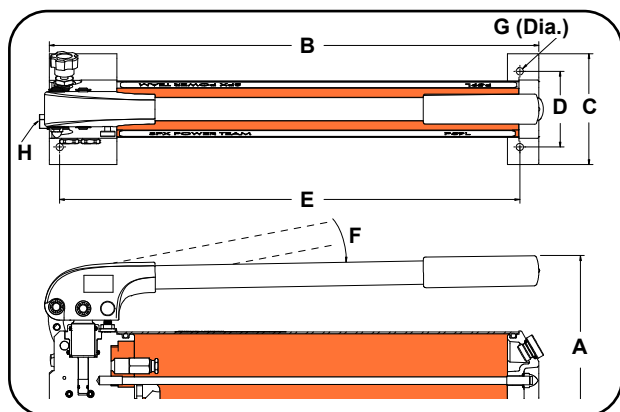

**Features**

**PUMP AUTOMATICALLY SHIFTS INTO THE HIGH PRESSURE LIFT STAGE UPON CONTACT WITH THE LOAD.**

- Two-speed reduces handle strokes so you work faster and easier.
- More usable oil volume allows for use with larger or longer stroke cylinders.
- True unloading valve provides more efficiency and lower handle force.
- Link design reduces handle effort by 40%.
- Durable aluminum reservoir, manifold, and end cap.
- Ergonomic non-slip handle grip provides more comfort.
- Spring loaded handle lock incorporated into handle.
- Aluminum design reduces weight.

▶ The P59L hand pump is able to quickly advance the cylinder to the load with it's two speed operation.



**Technical Dimensions**

Order No.	A (mm)	B (mm)	C (mm)	D (mm)	E (mm)	F (deg.)	G (mm)	H (in.)
P19L	141,5	—	104,1	82,6	347,7	40°	7,9	3/8 NPTF
P59L	177,8	—	—	82,6	533,4	50°	7,9	3/8 NPTF
P59L-1500	182,1	556,5	138,9	82,6	501,7	47°	7,9	9/16-18 UNF**
P59L-1500G*	182,1	556,5	138,9	82,6	501,7	47°	7,9	9/16-18 UNF**

\* Overall length, with the skid-plate is 719 mm.

\*\* 60° cone fitting.

**Ordering Information**

For Use With	Speed	Order No.	Volume per Stroke		Max. Pressure		Handle Effort (kg)	Reservoir		Oil Port (cm)	Prod. Wt. (kg)
			LP (cm <sup>3</sup> )	HP (cm <sup>3</sup> )	LP (bar)	HP (bar)		Oil Cap. (cm <sup>3</sup> )	Usable Oil Cap. (cm <sup>3</sup> )		
Single-Acting Cylinders	2	P19L	4,1	0,9	70	700	37	475	443	3/8 NPTF	2,3
	2	P59L	12,0	2,6	59	700	44	1131	1082	3/8 NPTF	4,1
	2	P59L-1500	11,1	0,88	20	1500	32,7	1100	729,2	3/4 - 16 UNF	4,7
	2	P59L-1500G*	11,1	0,88	20	1500	32,7	1100	729,2	3/4 - 16 UNF	6,5

\* Equipped with a skid plate and a digital gauge.  
LP = Low Pressure, HP = High Pressure

**CAUTION:** P59L-1500 pumps are not recommended for use with 700 bar tools.

Model Shown:

**P300, P157, P159D, P460**

Pumps



**Features**

**HEAVY-DUTY STEEL HAND PUMPS HOLD UP TO THE MOST DEMANDING APPLICATIONS.**

- Rugged all metal construction for strength and durability that won't burn through in welding environments.
- Heavy-duty, formed metal handle provides rigidity, and reduces operator fatigue with grip.
- Convenient oil fill ports.
- Fill cap seal acts as safety valve to prevent over-pressurizing of reservoir.
- Relief valve inboard of check valve prevents loads from drifting down.
- Large valve knob gives added control for slowly metering loads down.

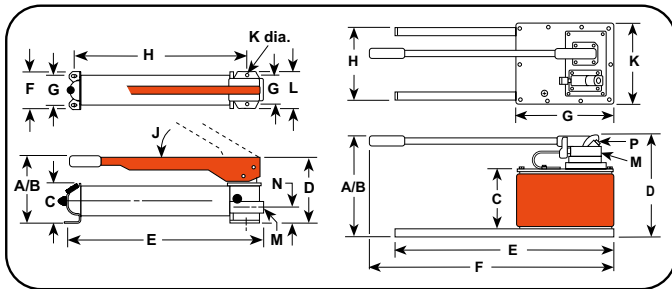

**Foot Pump Conversion Kit**

For Use With:	Kit Order No.	Wt. (kg)
P157, P159, P300, P300D	<b>FK159B</b>	2,7



**Technical Dimensions**

Order No.	A (cm)	B (cm)	C (cm)	D (cm)	E (cm)	F (cm)	G (cm)	H (cm)	J (deg.)	K (cm)	L (cm)	M (cm)	N (cm)	P (cm)
<b>P157 / P159</b>	197	521	123,8	175	578	98,4	76,2	502	39	7,9	95,3	3/8 NPTF	57,2	—
<b>P300</b>	210	522	114,3	175	575	215,9	190,5	526	39	7,9	95,3	3/8 NPTF	57,2	—
<b>P460</b>	283	787	171,5	289	610	743	279,4	229	80	241,3	—	3/8 NPTF	—	1/4 NPTF

**Ordering Information**

For Use With	Speed	Order No.	Volume per Stroke		Max. Pressure		Handle Effort (kg)	Reservoir		Oil Port (cm)	Prod. Wt. (kg)
			LP	HP	LP	HP		Oil Cap.	Usable Oil Cap.		
			(cm <sup>3</sup> )	(cm <sup>3</sup> )	(bar)	(bar)		(cm <sup>3</sup> )	(cm <sup>3</sup> )		
Single-Acting Cylinders	2	<b>P157</b>	10,7	2,6	97	700	64	2491	2245	3/8 NPTF	11,8
	2	<b>P159</b>	42,6	2,6	22	700	64	2491	2245	3/8 NPTF	11,8
	2	<b>P300</b>	42,6	2,6	22	700	64	5700	5081	3/8 NPTF	25,1
	2	<b>P460</b>	120,5	4,6	22	700	41	9500	7539	3/8 NPTF	24,9
Double-Acting Cylinders*	2	<b>P157D</b>	10,7	2,6	97	700	64	2491	2245	3/8 NPTF	13,1
	2	<b>P159D</b>	42,6	2,6	22	700	64	2491	2245	3/8 NPTF	12,7
	2	<b>P300D</b>	42,6	2,6	22	700	64	5700	5081	3/8 NPTF	25,9
	2	<b>P460D</b>	120,5	4,6	22	700	41	9500	7539	3/8 NPTF	26,3

\* Pump includes 4-Way Valve LP = Low Pressure, HP = High Pressure

Model Shown:

**RPS1006, RPS203H**



**Features**

**PRECISION-MATCHED CYLINDER AND PUMP SET FOR WIDE RANGE OF APPLICATIONS.**

- Four styles of cylinders to choose from.
- Sets feature single or two-speed hydraulic hand pumps.
- Cylinders of various tonnages with long, medium or short stroke.
- Includes necessary fittings, couplers and 1,8 m hose.

Pumps

**OPTIONAL: STORAGE BOX**



Storage box for hydraulic cylinder and pump sets. Rugged industrial strength material, strong as steel, never needs painting, won't rust, dent or chip. Weatherproof lid is self sealing and lockable. Molded-in handles, water-tight, one piece bottom and side construction. Strong enough to stand on. Note: Actual product may differ from photo.

Order No.	Dimensions	Wt. (kg)
350722	940 mm L x 533 mm H x 508 mm W	10,4

**Ordering Information**

Style of Cylinder	Cyl. Cap. (tons.)	Stroke (cm)	Order No.	Re-tracted Height (cm)	Handle Strokes Required to Fully Extend Cylinders	Cylinder No.	Pump No.	Hose No.	Coupler No.	Pump Speed	Prod. Wt. (kg)
"C" Series	4,5	133,4	RPS55	216	75	C55C	P12	9756E	9798	Single	5,4
	9	54,0	RPS102**	121	32	C102C	P55	9756E	9798	Single	11,8
	9	155,6	RPS106**	248	93	C106C	P55	9756E	9798	Single	14,5
	9	257,2	RPS1010**	349	154	C1010C	P55	9756E	9798	Single	16,1
	14	104,8	RPS154**	200	81	C154C	P55	9756E	9798	Single	13,1
	14	155,6	RPS156**	271	118	C156C	P55	9756E	9798	Single	15,4
	23	158,8	RPS256**	273	219	C256C	P55	9756E	9798	Single	19,3
	23	362,0	RPS2514**	476	285*	C2514C	P159	9756E	9798	Two	28,4
	50	158,8	RPS556**	283	268*	C556C	P159	9756E	9798	Two	37,5
"Shorty"	91	168,3	RPS1006	337	428*	C1006C	P460	9756E	9798	Two	58,3
	24	61,9	RPS302**	117	61*	RSS302	P59	9756E	9798	Two	18,1
	45	60,3	RPS552**	127	89*	RSS502	P59	9756E	9798	Two	22,7
"Center-Hole"	91	57,2	RPS1002**	140	172*	RSS1002	P59	9756E	9798	Two	36,7
	18	76,2	RPS203H**	154	80	RH203	P55	9756E	9798	Single	18,3
Alum.	50	155,6	RPS556A**	273	262*	RA556	P159	9756E	9798	Two	21,3

\* Based on 50% of the stroke being made at low-pressure and 50% of the strokes at high pressure.  
 \*\* Add suffix "B" (example: RPS102B, RPS203HB, etc.) to order set with optional storage box shown above.

Model Shown:

**PA6, PA6M-1, PA6-2**



**Features**

**COMPACT, LIGHTWEIGHT AND PORTABLE. SINGLE-SPEED PUMPS DESIGNED TO DRIVE SINGLE-ACTING CYLINDERS.**

- The power unit of choice for major manufacturers of auto body, frame straighteners and other shop equipment.
- Operate at 3-8 bar shop air pressure at the pump.
- Quiet operation that is suitable for indoor applications, 85 dBA at 700 bar.
- Serviceable pump motor is not a “throw away” providing economical repair.
- Permanently vented reservoir cap.
- ATEX Certified
- Internal relief valve protects circuit components, air inlet filter protects motor.



**Typical Set-Up**

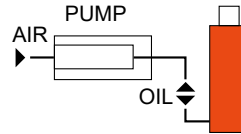

Hook-up for single-acting cylinders

▶ **PA6 is the perfect choice for driving this nut splitter in this heavy truck shop.**

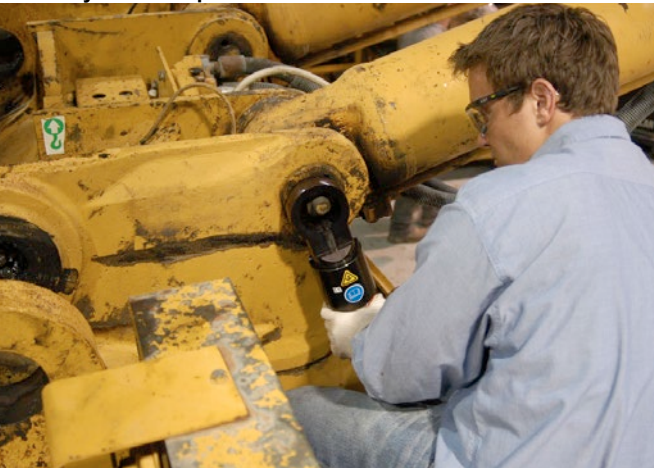

▶ **Performance Specifications**

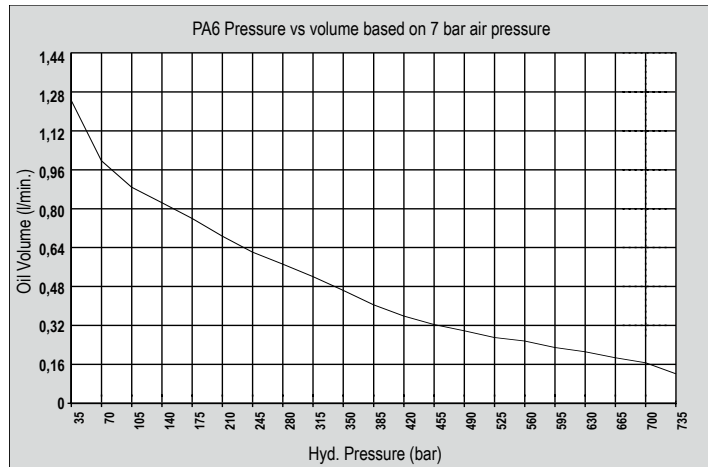

▶ **Two Point Lifting System Example**



Pumps

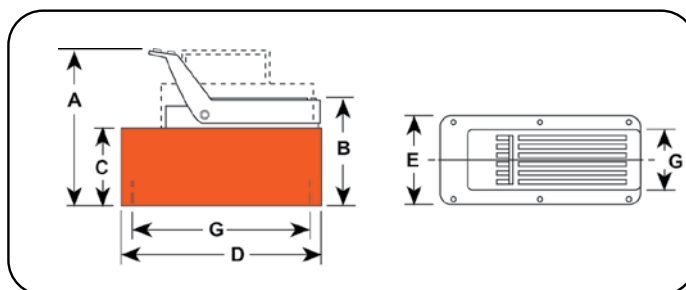

▶ **Technical Dimensions**

Order No.	A	B	C	D	E	G
	(mm)	(mm)	(mm)	(mm)	(mm)	(mm)
PA6	197	149	111	241	127	102 x 229
PA6A	197	149	111	241	127	102 x 229
PA6AM	197	149	111	241	127	102 x 229
PA6M	197	149	111	241	127	102 x 229
PA6R	197	149	111	241	127	102 x 229
PA6RM	197	149	111	241	127	102 x 229
PA6M-1	200	152	111	321	187	—
PA6-2	254	197	171	292	241	203 x 254
PA6M-2	260	203	178	292	241	130 x 181

▶ **Ordering Information**

Description	Order No.	Air Supply Req'd (bar)	Air Cons. Rate (l/min)	Reservoir		Air Inlet Thread size	Oil Port (in.)	Prod. Wt. (kg)
				Oil Cap. (l)	Usable Oil Cap. (l)			
Base model pump with high density polyethylene reservoir.	PA6	3 - 8	570 l/min	1,7	1,6	1/4 NPFT	3/8 NPTF	6,3
PA6 pump with externally adjustable relief valve and polyethylene reservoir	PA6A	3 - 8	570 l/min	1,7	1,6	1/4 NPFT	3/8 NPTF	6,8
PA6 pump with externally adjustable relief valve and metal reservoir.	PA6AM	3 - 8	570 l/min	1,7	1,6	1/4 NPFT	3/8 NPTF	7,7
PA6 pump with metal reservoir.	PA6M	3 - 8	570 l/min	1,7	1,6	1/4 NPFT	3/8 NPTF	8,2
PA6 pump with 3,7 m remote control and polyethylene reservoir	PA6R	3 - 8	570 l/min	1,7	1,6	1/4 NPFT	3/8 NPTF	9,3
PA6 pump with 3,7 m remote control and metal reservoir.	PA6RM	3 - 8	570 l/min	1,7	1,6	1/4 NPFT	3/8 NPTF	9,8
PA6 pump with 3,8 l metal reservoir.	PA6M-1	3 - 8	570 l/min	3,8	3,0	1/4 NPFT	3/8 NPTF	10,7
PA6 pump with 7,6 l high density polyethylene reservoir.	PA6-2	3 - 8	570 l/min	7,6	7,3	1/4 NPFT	3/8 NPTF	11,1
PA6 pump with 9,5 l metal reservoir.	PA6M-2	3 - 8	570 l/min	9,5	9,1	1/4 NPFT	3/8 NPTF	14,5

Model Shown:  
**PA6D**



Pumps

**Features**

**COMPACT, LIGHTWEIGHT AND PORTABLE SINGLE-SPEED PUMP FOR DRIVING DOUBLE-ACTING CYLINDERS.**

- Operate at 3-8 bar shop air pressure at the pump.
- Internal relief valve protects circuit components while the air inlet filter protects motor.
- Serviceable pump allows for economical repairs.
- Permanently vented reservoir cap.
- 85 dBA at 700 bar for all PA6 pumps.



**Typical Set-Up**

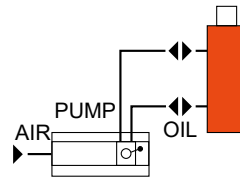

Hook-up for double-acting cylinders

▶ PA6D pump, 9052 analog and 23 ton cylinder used in a test fixture.



**Performance Specifications**

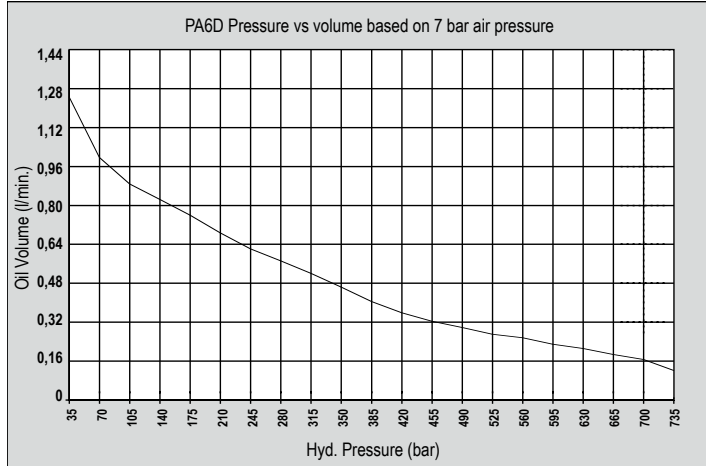

Model Shown:

**PA6D2, PA6DM-1**



Pumps

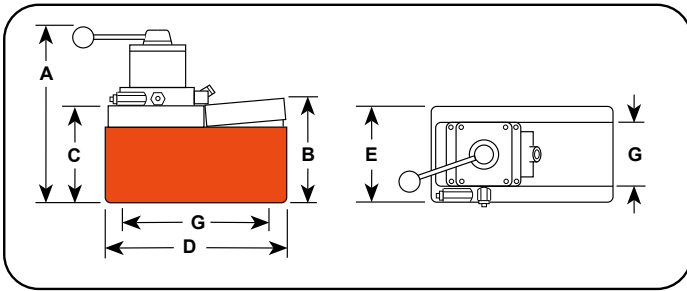

► **Technical Dimensions**

Order No.	A (mm)	B (mm)	C (mm)	D (mm)	E (mm)	G (mm)
PA6D	264	149	111	241	127	102 x 229
PA6DM	264	149	111	241	127	102 x 229
PA6DM-1	279	146	111	321	187	—
PA6D2	324	203	178	287	235	130 x 181
PA6DM-2	318	197	171	292	241	203 x 254

► **Technical Dimensions**

Description	Order No.	Valve No.	Air Supply Req'd (bar)	Reservoir		Oil Port (in.)	Prod. Wt. (kg)
				Oil Cap. (l)	Usable Oil Cap. (l)		
Base model pump with high density polyethylene reservoir.	PA6D	9504, 3-way/4-way	3-8	1,7	1,6	3/8 NPTF	8,3
PA6D pump with metal reservoir.	PA6DM	9504, 3-way/4-way	3-8	1,7	1,6	3/8 NPTF	9,2
PA6D pump with 3,8 l metal reservoir.	PA6DM-1	9504, 3-way/4-way	3-8	3,8	3,0	3/8 NPTF	12,7
PA6D pump with 7,6 l high density polyethylene reservoir.	PA6D2	9504, 3-way/4-way	3-8	7,6	7,3	3/8 NPTF	13,0
PA6D pump with 9,5 l metal reservoir.	PA6DM-2	9504, 3-way/4-way	3-8	9,5	9,1	3/8 NPTF	16,4

Model Shown:

**PA9 Foot Control, PA9H Hand Control**

Pumps



**Features**

**IDEAL FOR POWERING SINGLE-ACTING CYLINDERS AND PORTABLE HYDRAULIC TOOLS.**

- Easier to operate than a hand pump, giving you the speed you need at an affordable price.
- Serviceable pump allows for economical repairs.
- Unique bladder design for all-position operation and storage.
- Operates on 3-8 bar shop air, at 570 l.
- 80 db @ 700 Bar
- Hard-coat anodized aluminum housing.
- ATEX Certified
- Oil filler with integral safety relief minimizes chance of damage to reservoir bladder if overfilling occurs.

**Typical Set-Up**

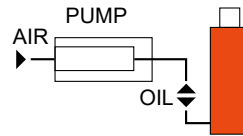

Hook-up for single-acting cylinders

▶ **PA9H Hand Control Pump used in a straightening press.**



▶ **Performance Specifications**

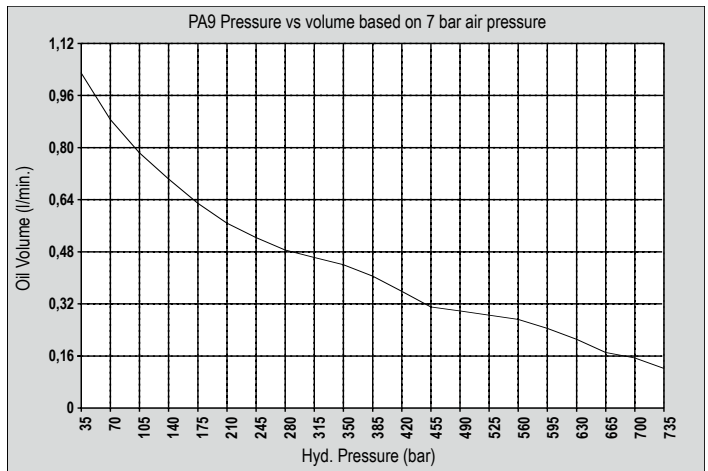

▶ **PA9 Foot Control**

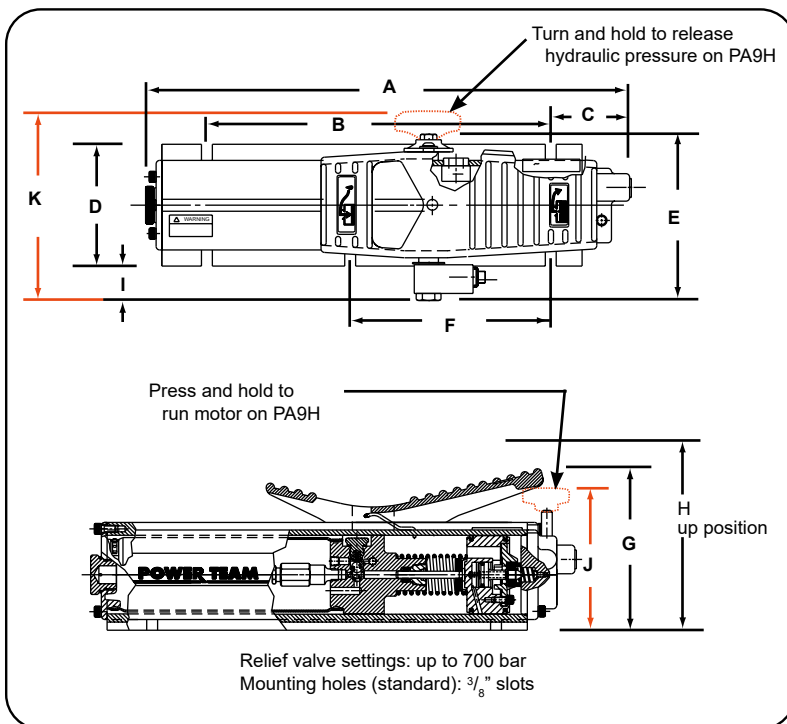

Pumps

▶ **Technical Dimensions**

Order No.	A	B	C	D	E	F	G	H	I	J	K
	(mm)	(mm)	(mm)	(mm)	(mm)	(mm)	(mm)	(mm)	(mm)	(mm)	(mm)
PA9	432	305	71,4	108	149	178	142	178	28,2	—	—
PA9H	432	305	71,4	108	—	178	—	178	28,2	122	170

▶ **Ordering Information**

For Use With Cyl. Type	Order No.	Air Supply Req'd (bar)	Air Inlet Thread Size	Reservoir		Oil Port (in.)	Max. Pressure Output (bar)	db@700 bar	Prod. Wt. (kg)
				Oil Cap. (cm <sup>3</sup> )	Usable Oil Cap. (cm <sup>3</sup> )				
Single-Acting	PA9	3-8	1/4 NPFT	574	549	3/8 NPTF	700	80	6,8
Single-Acting	PA9H	3-8	1/4 NPFT	574	549	3/8 NPTF	700	80	6,8

Model Shown:  
**PA64**



**Features**

**TWO-SPEED PUMP FOR RAPID OIL DELIVERY AT LOW PRESSURE QUICKLY ADVANCES CYLINDER OR TOOL.**

- Equipped with air pressure regulator, air filter and lubricator.
- Serviceable air motor for economical repair.
- Internal relief valve protects circuit components.
- ATEX Certified
- Permanently vented reservoir cap.



**Typical Set-Up**

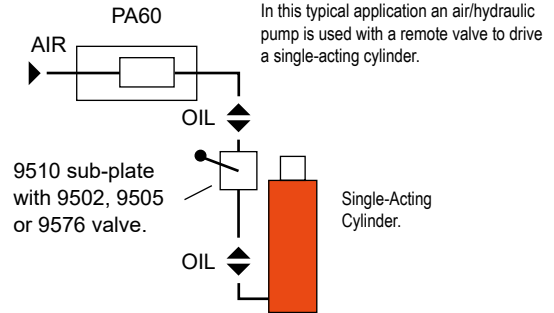

**The PA60 used in a work-holding environment**



**Performance Specifications**

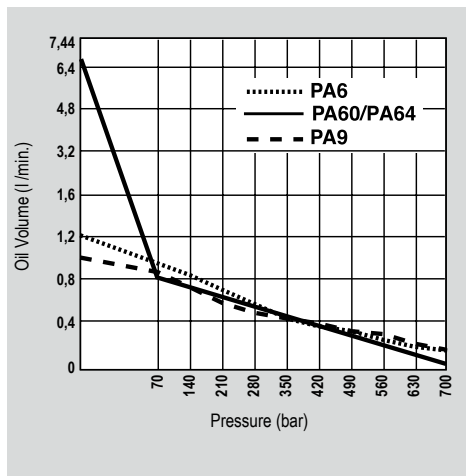

Model Shown:

**PA60**

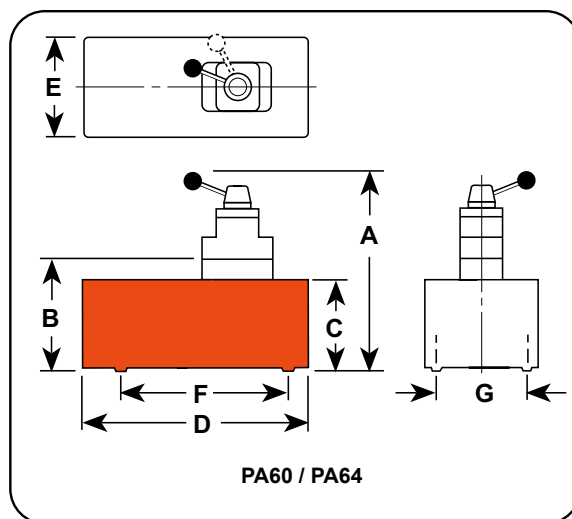

Pumps

► **Technical Dimensions**

Order No.	A (mm)	B (mm)	C (mm)	D (mm)	E (mm)	F (mm)	G (mm)	Max. Pressure Output (bar)	Oil Del. (l/min. @) *				
									0 (bar)	7 (bar)	70 (bar)	350 (bar)	700 (bar)
PA60	—	240	206	362	244	181	130	700	6,24	5,6	0,8	0,19	0,1
PA64	362	—	206	362	244	181	130	700	6,24	5,6	0,8	0,19	0,1

\* Typical delivery. Actual flow will vary with field conditions.

► **Technical Dimensions**

Description	Order No.	Valve No.	Valve Function	Air Supply Req'd (bar)	Reservoir		Oil Port (in.)	Prod. Wt. (kg)
					Oil Cap. (l)	Usable Oil Cap. (l)		
For use with remote valves.	PA60	9626 Manifold	—	3 - 8	7,6	6,8	3/8 NPTF	24,5
For use with single or double-acting cylinders	PA64	9507 3/4-Way	Advanced Hold Return	3 - 8	7,6	6,8	3/8 NPTF	24,5

Model Shown:

**PA50D, PA50M, PA50R2**



### Features

**SINGLE-SPEED, LOW PRESSURE (220 BAR) OUTPUT PUMPS.**

- Serviceable air motor for economical repair.
- Air inlet filter protects air motor.
- Filter in outlet port protects against contaminated systems.
- ATEX Certified
- Assorted reservoirs to suit your application's requirements.

### The PA50 used in a work-holding environment



### Performance Specifications

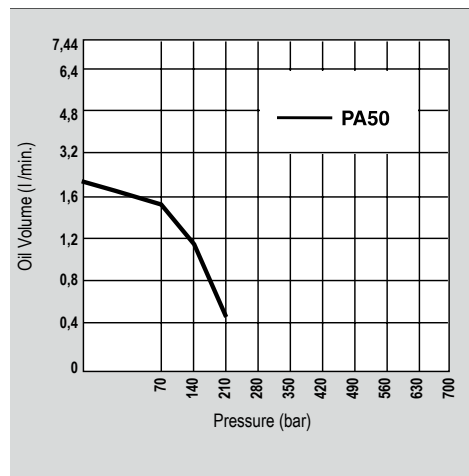

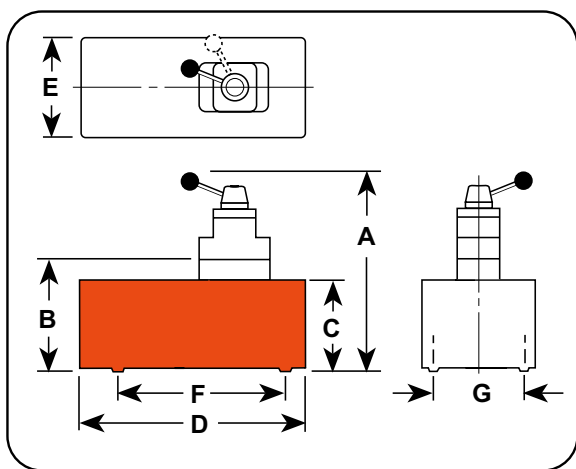

### Hydraulic Hoses

Heavy-duty and thermo plastic hydraulic hoses to meet your requirements and safety factor.

Refer to the accessories section for details.



### Analog Gauges

Improve your system visibility and safety by adding an inline hydraulic gauge to your circuit.

9040E (63 mm)  
9052E (100 mm)



### Technical Dimensions

Order No.	A	B	C	D	E	F	G	Max. Pressure Output (bar)	Oil Del. (l/min. @) *			
	(mm)	(mm)	(mm)	(mm)	(mm)	(mm)	(cm)		0 (bar)	7 (bar)	170 (bar)	220 (bar)
PA50, PA50R	197	149	111	241	127	—	102 x 229	220	2,05	1,76	1,41	0,45
PA50R2	260	203	178	292	241	—	130 x 181	220	2,05	1,76	1,41	0,45
PA50D	264	149	111	241	127	229	102	220	2,05	1,76	1,41	0,45

\* Typical delivery. Actual flow will vary with field conditions.

### Ordering Information

For Use With Cylinder Type	Description	Order No.	Valve No.	Air Supply Req'd (bar)	Reservoir		Oil Port (in.)	Prod. Wt. (kg)
					Oil Cap. (l)	Usable Oil Cap. (l)		
Single-Acting	Base model pump with high density polyethylene reservoir.	PA50	—	3 - 8	1,7	1,6	3/8 NPTF	6,4
Single-Acting	PA50, except has 3,7 meter remote control.	PA50R	—	3 - 8	1,7	1,6	3/8 NPTF	8,4
Single-Acting	PA50R, except has 7,6 liter reservoir.	PA50R2	—	3 - 8	7,6	7,3	3/8 NPTF	12,9
Single and Double-Acting	PA50 pump with valve and polyethylene reservoir.	PA50D	9504	3 - 8	1,7	1,6	3/8 NPTF	8,4

Notes: Air inlet port 1/4" NPTF. Requires 570 l/min at 7 bar shop air pressure at the pump to achieve 220 bar.

Model Shown:  
**PA172, PA174**

Pumps



## Features

**ROTARY-STYLE AIR MOTOR. USE WHERE AIR IS THE PREFERRED SOURCE OF ENERGY.**

- Two-speed operation for high speed cylinder advance.
- Durable 7,6 liter thermoplastic reservoir. (Metal reservoir conversion kits are available.)
- ATEX Certified
- Air motor capable of starting under full load.

▶ The PA17 used with a flange spreader



▶ Performance Specifications

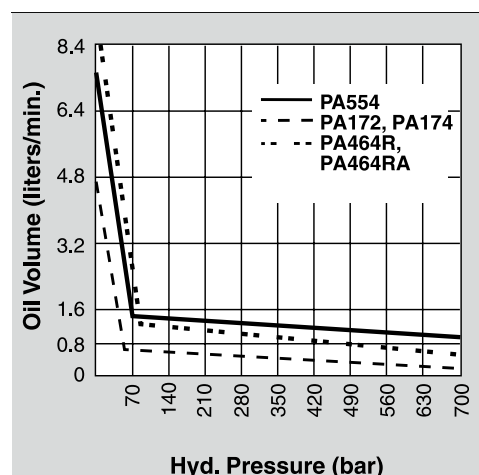



**Hydraulic Hoses**

Heavy-duty and thermo plastic hydraulic hoses to meet your requirements and safety factor.

Refer to accessories section for details



**Hydraulic Fluids**

For dependable performance of all your hydraulic pumps and cylinders. Power Team specialty blended oils contains foam suppressant additives and has a high viscosity index. Refer to the Accessories section for complete details



**Learn More - About Hydraulic Safety Insight**



Looking for great safety suggestions? Visit our Resource Section to get a better understanding of hydraulic and mechanical safety insights on what to look for when working around hydraulics

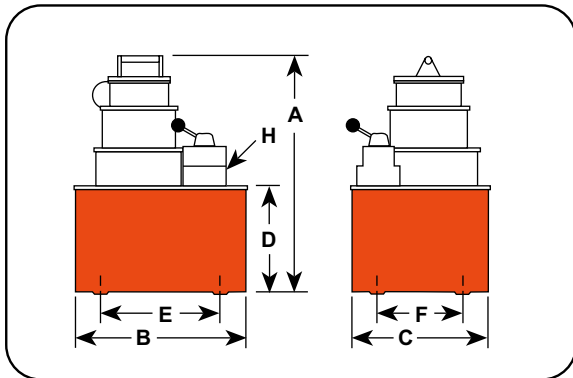

**Technical Dimensions**

Order No.	A	B	C	D	E	F	H	Max. Pressure Output	Oil Del. (l/min. @) *				
									0	7	70	350	700
	(mm)	(mm)	(mm)	(mm)	(mm)	(mm)	(in.)	(bar)	(bar)	(bar)	(bar)	(bar)	
PA172	359	289	235	178	181	130	3/8 NPTF	700	4,6	3,8	0,4	0,4	0,3
PA174	359	289	235	178	181	130	3/8 NPTF	700	4,6	3,8	0,4	0,4	0,3

\* Typical delivery. Actual flow will vary with field conditions.

**Ordering Information**

For Use With Cylinder Type	Description	Order No.	Valve No.	Valve Function	Air Supply Req'd (bar)	Reservoir		Prod. Wt. (kg)
						Oil Cap. (L)	Usable Oil Cap. (L)	
Single-Acting	Base model pump with 7,6 liter thermoplastic reservoir.	PA172	9517, 2-way	Advance Return*	3-8	7,6	4,7	18,1
Single and Double-Acting	PA172, except has 9500 valve for use with single or double-acting cylinders	PA174	9500, 4-way	Advance Hold Return*	3-8	7,6	4,7	18,6

\* Holds pressure in advance position when valve motor is shut-off or in return position with motor running. Pump will build pressure when motor is shut-off and oil returns to reservoir.

Notes: Requires 1133 l/min at 7 bar shop air pressure at the pump. 85/90 dBA at 700 bar.

Model Shown:

**PA462, PA464R, PA554**

Pumps



**Features**

**ROTARY-STYLE AIR MOTOR. USE WHERE AIR IS THE PREFERRED SOURCE OF ENERGY.**

- 2,2 kW motor starting under full load.
- Two-speed operation for rapid cylinder advance.
- Models available with full remote control over advance and return, (except PA554).
- ATEX Certified
- Tandem center valve holds the load when pump is shut-off.



**Torque Wrench Pumps**



For Torque Wrench Pump Configurations, refer to the Tools Section.

▶ **PA554 pump and RH2008 Center Hole cylinder used to tension cables.**



▶ **Performance Specifications**

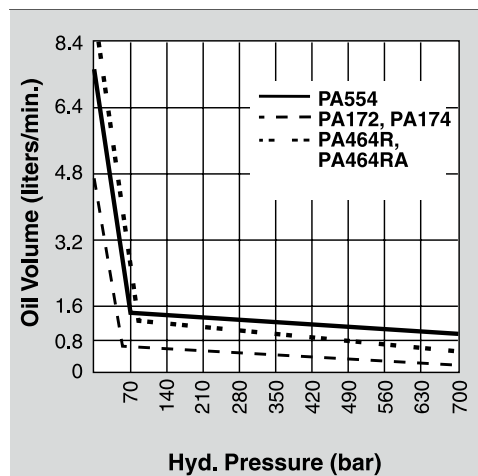

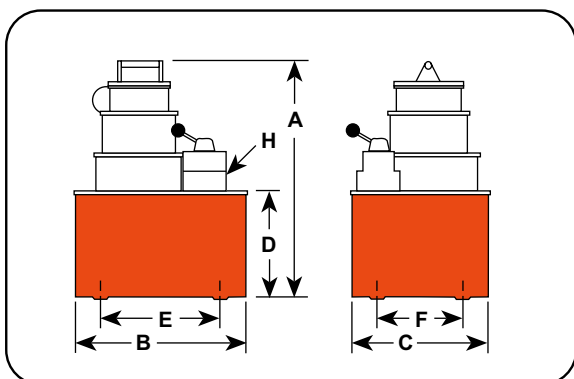

**Analog Gauges**



Improve your system visibility and safety by adding an inline hydraulic gauge to your circuit.

**9040E (63 mm)**  
**9052E (100 mm)**

Pumps

**Technical Dimensions**

Order No.	A (mm)	B (mm)	C (mm)	D (mm)	E (mm)	F (mm)	H (in.)	Max. Pressure Output (bar)	Oil Del. (l/min. @) *				
									0 (bar)	7 (bar)	70 (bar)	350 (bar)	700 (bar)
PA462	381	292	241	178	254	203	3/8 NPTF	700	7,4	7,2	0,8	0,8	0,7
PA464	381	292	241	178	254	203	3/8 NPTF	700	7,4	7,2	0,8	0,8	0,7
PA464R	381	292	241	178	254	203	3/8 NPTF	700	7,4	7,2	0,8	0,8	0,7
PA464RA	381	292	241	178	254	203	3/8 NPTF	700	7,4	7,2	0,8	0,8	0,7
PA554	483	292	241	178	254	203	3/8 NPTF	700	7,4	7,2	1,3	1,1	0,7

\* Typical delivery. Actual flow will vary with field conditions.

**Note:** Reservoir has four 1/2" - 20 mounting holes.

**Ordering Information**

For Use With Cylinder Type	Description	Order No.	Valve Number	Valve Function	Air Supply Req'd (bar)	Reservoir		Prod. Wt. (kg)
						Oil Cap. (L)	Usable Oil Cap. (L)	
Single-Acting	Base model pump with 9,6 liter steel reservoir.	PA462	9584, 2-way	Advance/ Hold/Return	3 - 8	9,5	9,4	27,2
Single and Double-Acting	PA462, except has 9500 valve capable of running 2 single-acting cylinders or one double-acting cylinder.	PA464	9500, 4-way	Advance/ Hold/Return*	3 - 8	9,5	9,4	27,6
Single and Double-Acting	PA462 with air actuated valve for full remote control over advance and return. Includes 3,7 meter remote control.	PA464R†	9594, 4-way	Advance/ Hold/Return	3 - 8	9,5	9,4	35,3
Single and Double-Acting	PA464R except, has automatic dump feature. 7,6 meter remote control.	PA464RA**†	9594, 4-way	Advance/ Hold/Return*	3 - 8	9,5	9,4	35,8
Single and Double-Acting	High performance pump with 9,5 liter steel reservoir.	PA554	9500, 4-way	Advance/ Hold/Return*	3 - 8	9,5	8,4	32,0

\* Holds when motor is shut-off and valve is in "advance" position.

\*\* Not to be used for lifting.

† The PA464RA has an "automatic dump" feature. Pressure is not held when operator releases "advance" or "return" button. PA464R will "hold" only in the "advance" position with the motor shut-off.

**Notes:** Requires 1420 l/m at 5,5 bar shop air pressure at the pump. 85/90 dBA at 700 bar.

Model Shown:

**PB43MA1P-1**



60VDC 8Ah battery and charger Included

Pumps

**Features**

- Two-stage, high-pressure 700 BAR (10k PSI) hydraulic pump offers quick tool advancement in the first stage with industry leading second stage mid pressure flow: 1344 cm<sup>3</sup>/m (82 in<sup>3</sup>/m) 138 BAR (2,000 PSI), 98cm<sup>3</sup>/m (62 in<sup>3</sup>/m) 483 BAR (7,000 PSI), 705cm<sup>3</sup>/m (43 in<sup>3</sup>/m) 700 BAR (10,000 PSI)
- Quiet, 75 dBA at max pressure great option for indoor applications or where noise is a concern.
- 2.1HP (1.56 KW) motor provides ample power to support high-pressure performance
- Wide array of valve options allowing a hydraulic circuit that fits your exact needs
- Lightweight and portable, 33 kgs. with battery and oil
- Motor guard and integrated lifting handle offer increased protection and transportation to job sites hassle-free
- Ergonomic IP55 rated remote pendant with 12 ft / 3.6m cord and large button design, requiring low finger depression force to operate, decreasing operator fatigue
- 60V DC Battery, Battery charger, protective cage and valve choice included with purchase
- Reservoir size options available, refer to pump configuration page

## PUMP TECHNOLOGY AT A GLANCE

1. 130 cycles on a RD106 cylinder to 10k PSI holding and retracting to 10k PSI and holding, providing 30 minutes of continuous run time on a single charge (1.5-hour charge time)
2. Many valve configurations available
3. Robust protective cage with carrying handle for ease of transport
4. Powerful 60V motor with long runtime 8Ah battery
5. Easy access battery compartment with protective flip up lid.
6. Deep draw reservoir with O-ring Lip for leak-free operation
7. Inserts for fixturing or mounting optional full roll cage
8. Equipped with the industry leading Vanguard™ pump technology
9. 1-button (jog) pendant with on-board storage



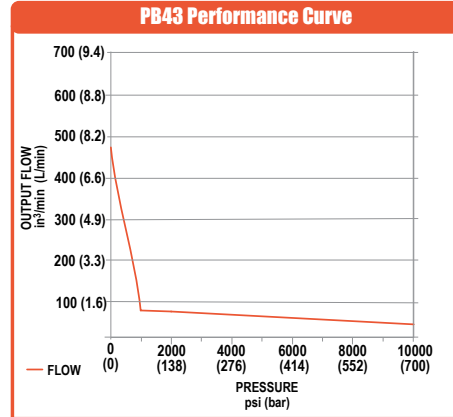
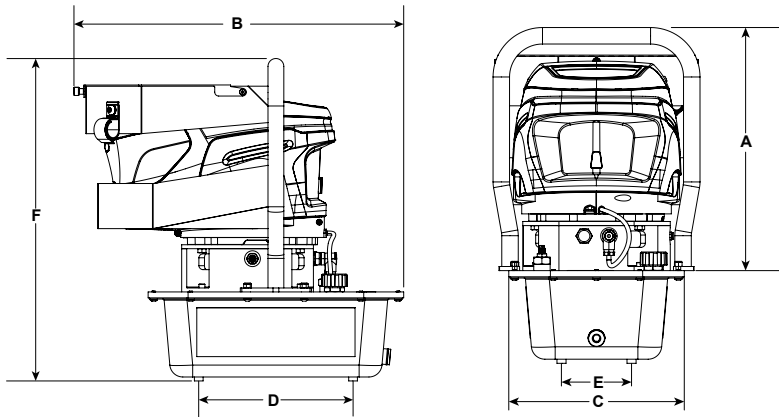

**Technical Dimensions**

A	B	C	D	E	F	Max Press. Output Bar (psi)	RPM	dBA at Idle and Max Press	Oil Delivery - l/min (cu.in/min) @				Wt* kg (lbs)
millimeters (inches)									7 Bar (100psi)	35 Bar (500psi)	350 Bar (5000 psi)	700 Bar (10000 psi)	
374.65 (14.75)	529.59 (20.85)	318.77 (12.55)	247.65 (9.75)	107.95 (4.25)	517.39 (20.37)	700 (10,000)	3100	73 / 75	7.8 (480)	1.3 (78)	1.2 (70)	0.7 (43)	32.9 (72.5)

Recommended operating temperature range of pump is -25°C to +50°C (-13°F to 122°F)  
\* Weight typical for basic unit PB43MA1P-1, including oil and battery (Charger not included in weight)

**Model Numbers / Ordering Information**

Part Number	Reservoir size Liters (US Gal)	Usable Oil Cap. Liters (US Gal)	Valve	Cylinder Applications	Operation	Valve type	Adv/Ret	Adv/ Hold/ Ret	PosiCheck
PB43MA1P-1	5.7 (1.5)	4.8 (1.28)	9500	SA / DA	Manual	4-Way, 3-Pos. Tandem Center	No	Yes	No
PB43MD1P-1	5.7 (1.5)	4.8 (1.28)	9506	SA / DA	Manual	4-Way, 3-Pos. Tandem Center	No	Yes	Yes
PB43MH1P-1	5.7 (1.5)	4.8 (1.28)	9520	SA	Manual	3-Way, 3-Pos. Tandem Center	No	Yes	Yes
PB43MI1P-1	5.7 (1.5)	4.8 (1.28)	9582-A	SA	Manual	3-Way, 2-Pos.	No	Yes	No
PB43ML1P-1	5.7 (1.5)	4.8 (1.28)	9628	SA / DA	Manual	Post-Tensioning	Special	No	No
PB43MA2P-1	9.5 (2.5)	8.7 (2.30)	9500	SA / DA	Manual	4-Way, 3-Pos. Tandem Center	No	Yes	No
PB43MD2P-1	9.5 (2.5)	8.7 (2.30)	9506	SA / DA	Manual	4-Way, 3-Pos. Tandem Center	No	Yes	Yes
PB43MH2P-1	9.5 (2.5)	8.7 (2.30)	9520	SA	Manual	3-Way, 3-Pos. Tandem Center	No	Yes	Yes
PB43MI2P-1	9.5 (2.5)	8.7 (2.30)	9582-A	SA	Manual	3-Way, 2-Pos.	No	Yes	No
PB43ML2P-1	9.5 (2.5)	8.7 (2.30)	9628	SA / DA	Manual	Post-Tensioning	Special	No	No

\* When ordering 115V 60HZ Charger US plug use (-1) for the 200-240V 50/60HZ Charger CE EU plug use (-2) for the 200-240V 50/60HZ Charger UK plug use (-3) for the 200-240V 50/60HZ Charger AU plug use (-4)  
Example: (PB43MA1P-1 / PB43MA1P-2/ PB43MA1P-3 / PB43MA1P-4)

**“PLUG & PLAY” ACCESSORIES**

Order No.	Description
3001185	Full Roll Cage for use with PB43 pumps Wt. 4.5kg (10lbs)
2010995	115VAC 60HZ Charger with US plug
2011156	230V 50/60HZ CE Charger with EU plug
3001464	230V 50/60HZ CE Charger with UK plug
3001465	230V 50/60HZ CE Charger with AU plug
2010994	60VDC-8Ah Li-ION Global Battery

**Powerthon**  
**Limited**  
**Lifetime**  
**WARRANTY**

**Worry-Free Ownership**

ISO 9001 Certified

Pumps

Model Shown:

**PB102-1, PB102P-1**



Pumps

**Features**

**COMPACT, PORTABLE, CORDLESS HYDRAULIC PUMP FOR MRO APPLICATIONS.**

- Compact, Li-ion 18VDC, 9.0 Ah battery-powered pump provides extended run-time.
- Two-stage, high-pressure hydraulic pump offers quick tool advancement in the first stage.
- Extremely compact, lightweight with an ergonomic handle grip and transport strap to ease portability.
- Self-contained, rubber bladder reservoir allows pump usage in most positions with an impressive capacity of 1,1 l usable.
- Quiet, smooth-running, serviceable brushed 18VDC motor.
- High-impact, fiberglass reinforced shroud protects your investment in the most demanding and harsh applications.
- Interchangeable valve configuration accommodate a vast array of applications.
- CSA rated for intermittent duty, CE compliant.

**Ordering Information**

Order Number	Description	Refer to Note	Tool Type	Valve Type	Valve Function	Remote Control
PB102-0	18VDC, 1/4 HP Power Pump, S/A, 2-Way with Auto Dump	(1)	SA	2-Way/ Auto. Dump (9561)	Advance / Return (Auto)	Optional
PB102P-0	18VDC Power Pump, S/A, 2-Way with Auto Dump	(1)	SA	2-Way/ Auto. Dump (9561)	Advance / Return (Auto)	Hand Pendant with 3m cord included
PB102R-0	18VDC Power Pump, S/A, 2-Way with Auto Dump and Pressure Regulator	(1), (3)	SA	2-Way/ Auto. Dump / Pressure Regulator (9561, 9560)	Advance / Return (Auto) / Pressure Adjustment 70 -690 bar	Optional
PB102A-0	18VDC Power Pump, S/A, Auto Dump	(2)	SA	Auto. Dump (9562)	Advance / Return	Optional
PB104-0	18VDC Power Pump, D/A, 4-Way	(4)	DA	4-Way (9563)	Advance / Hold / Return	Optional
PB102-2	18VDC Power Pump, S/A, 2-Way with Auto Dump	(1)	SA	2-Way/ Auto. Dump (9561)	Advance / Return (Auto)	Optional
PB102P-2	18VDC Power Pump, S/A, 2-Way with Auto Dump	(1)	SA	2-Way/ Auto. Dump (9561)	Advance / Return (Auto)	Hand Pendant with 3m cord included
PB102R-2	18VDC Power Pump, S/A, 2-Way with Auto Dump and Pressure Regulator	(1), (3)	SA	2-Way/ Auto. Dump / Pressure Regulator (9561, 9560)	Advance / Return (Auto) / Pressure Adjustment 70 -690 bar	Optional
PB102A-2	18VDC Power Pump, S/A, Auto Dump	(2)	SA	Auto. Dump (9562)	Advance / Return	Optional
PB104-2	18VDC Power Pump, D/A, 4-Way	(4)	DA	4-Way (9563)	Advance / Hold / Return	Optional
PB102-3	18VDC, HP Power Pump, S/A, 2-Way with Auto Dump	(1)	SA	2-Way/ Auto. Dump (9561)	Advance / Return (Auto)	Optional
PB102P-3	18VDC Power Pump, S/A, 2-Way with Auto Dump	(1)	SA	2-Way/ Auto. Dump (9561)	Advance / Return (Auto)	Hand Pendant with 3m cord included
PB102R-3	18VDC Power Pump, S/A, 2-Way with Auto Dump and Pressure Regulator	(1), (3)	SA	2-Way/ Auto. Dump / Pressure Regulator (9561, 9560)	Advance / Return (Auto) / Pressure Adjustment 70 -690 bar	Optional
PB102A-3	18VDC Power Pump, S/A, Auto Dump	(2)	SA	Auto. Dump (9562)	Advance / Return	Optional
PB104-3	18VDC Power Pump, D/A, 4-Way	(4)	DA	4-Way (9563)	Advance / Hold / Return	Optional

(1) 2-Way Auto Dump Function: Flapper handle in "hold" position will allow the tool to advance and maintain pressure when the motor is shut off, flapper handle must be switched back to retract and dump pressure. Flapper handle is set to "return" position, power on will advance tool and power off will retract tool and dump pressure.

(2) Auto Dump Function: Power on - tool advances, and power off - tool returns, releasing pressure to tank.

SA = Single-Acting DA = Double-Acting

**► Technical Dimensions**

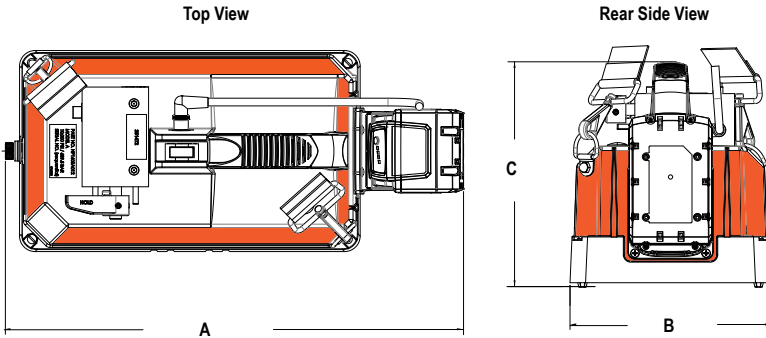

**Optional Remotes**

These remotes are equipped with connectors to enable the operator to "plug and play" the connection quickly. The wiring is configured to allow the operator to use the power switch on the pump or operate remotely once connected.



**Hand Pendant**  
Order # 3000989



**Foot Pendant**  
Order # 3000975

**► Hardware Included**



Turnkey, 690 bar hydraulic power pump powered by an 18VDC Li-ion battery, ships with hydraulic oil.



Transport shoulder strap with clips installed on shroud for quick fastening or removal.



One 18VDC Li-ion 9.0 Ah Battery, additional batteries can be purchased separately. Order #3000973



18VDC battery charger available in 230V for certain models, refer to the ordering information below.  
Order #2009647 EU, #2010141 UK

Flow @ Stages (cm <sup>3</sup> )	Usable Oil Capacity (cm <sup>3</sup> )	Battery Included	Charger (w/plug style)	Dimension (mm)			Weight (kg)	Order Number
				A	B	C		
1st Stage: 3300 cm <sup>3</sup> /min. @ 14 bar  2nd Stage: 98 cm <sup>3</sup> /min. @ 690 bar	1150	(1) One 18VDC Li-ion 9.0 Ah included	No charger is included	438	192	215	10,9	PB102-0
						215	11,8	PB102P-0
						242	11,3	PB102R-0
						192	10,9	PB102A-0
						259	11,3	PB104-0
1st Stage: 3300 cm <sup>3</sup> /min. @ 14 bar  2nd Stage: 98 cm <sup>3</sup> /min. @ 690 bar	1150	(1) One 18VDC Li-ion 9.0 Ah included	(1) One 230V M18 Charger Included, <b>Europe only</b>	438	192	215	10,9	PB102-2
						215	11,8	PB102P-2
						242	11,3	PB102R-2
						192	10,9	PB102A-2
						259	11,3	PB104-2
1st Stage: 3300 cm <sup>3</sup> /min. @ 14 bar  2nd Stage: 98 cm <sup>3</sup> /min. @ 690 bar	1150	(1) One 18VDC Li-ion 9.0 Ah included	(1) One 230V M18 Charger Included, <b>United Kingdom only</b>	438	192	215	10,9	PB102-3
						215	11,8	PB102P-3
						242	11,3	PB102R-3
						192	10,9	PB102A-3
						259	11,3	PB104-3

Model Shown:

**PB104XL-1, PB102XL-1**



Pumps

**Features**

**COMPACT, PORTABLE, CORDLESS HYDRAULIC PUMP FOR MRO APPLICATIONS.**

- Compact, Li-ion 18VDC, 8.0 Ah battery-powered pump provides extended run-time.
- Two-stage, high-pressure hydraulic pump offers quick tool advancement in the first stage.
- Extremely compact, lightweight with an ergonomic handle grip and transport strap to ease portability.
- Self-contained, rubber bladder reservoir allows pump usage in most positions with an impressive capacity of 289 cu.in. (4735.8 cu. cm.) usable.
- Quiet, smooth-running, serviceable brushed 18VDC motor.
- High-impact, fiberglass reinforced shroud protects your investment in the most demanding and harsh applications.
- Interchangeable valve configuration accommodates a vast array of applications.
- CSA rated for intermittent duty, CE compliant.

**Ordering Information**

Model Num.	Description	Ref. Note	Tool Type	Valve Type	Valve Function	Remote Control
PB102XL	18VDC Power Pump, SA 2W Dump	1	SA	2-Way Hold Auto Dump (9561)	Advance Hold Return	Optional
PB102XLP	18VDC Power Pump, SA 2W Dump	1	SA	2-Way Hold Auto Dump (9561)	Advance Hold Return	"Included Pendant w/ 10ft Cord"
PB102XLR	18VDC Power Pump, SA 2W Dump w/ Pressure Reg.	1, 3	SA	2-Way Hold Auto Dump w/Press. Reg. (9561, 9560)	Advance Hold Return Press. Adj. (1-10K)	Optional
PB102XLA	18VDC Power Pump, SA 2W Auto Dump	2	SA	2-Way Auto Dump (9562)	Advance Auto Return	Optional
PB102XL-CP	18VDC Power Pump, SA 2W Dump w/Pop Off RV	2, 5	SA	2-Way Dump w/ Pop Off RV (3001123)	Advance Auto Return	Optional
PB104XL	18VDC Power Pump DA, 4W	4	DA	4-Way (9563)	Advance HoldbReturn	Optional

(1) 2-Way Auto Dump Function: Flapper handle in "hold" position will allow the tool to advance and maintain pressure when the motor is shut-off, flapper handle must be switched back to retract and dump pressure. Flapper handle is set to "return" position, power on will advance tool and power-off will retract tool and dump pressure.  
 (2) Auto Dump Function: Power on - tool advances, and power-off - tool returns, releasing pressure to tank.

(3) Using the external knob, the pressure regulator valve allows the operator to externally adjust the pressure on demand, ranges from 500 - 10,000 psi.  
 (4) Four-way valve direction is controlled by the handle lever. Three position; Advance, hold, retract.  
 (5) For crimping applications only. Once full pressure is reached, RV provides audible noise.  
 SA = Single-Acting DA = Double-Acting

► **Technical Dimensions**

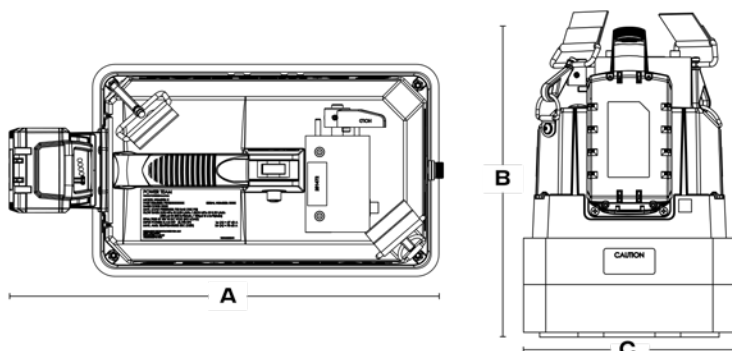

► **Hardware Included**



Turnkey, 10,000 PSI (690 bar) hydraulic power pump powered by an 18VDC Li-Ion battery, ships with hydraulic oil.



Transport shoulder strap with clips installed on shroud for quick fastening or removal.



One 18VDC Li-Ion 8.0 Ah Battery, additional batteries can be purchased separately.



18VDC battery charger available in 115VAC or 230VAC for certain models, excludes all -0 models

**Optional Remotes**

These remotes are equipped with connectors to enable the operator to “plug and play” the connection quickly. The wiring is configured to allow the operator to use the power switch on the pump or operate remotely once connected.

**Hand Switch**  
Order # 3000989

**Foot Pendant**  
Order # 3000975

Flow @ Stages cu. in./min (l/min)	Battery Included	Charger Included (Type)	XL Reservoir					XL Order Number					
			Oil Cap.	Dimensions			Wt.						
				L	W	H							
1st Stage: 200 (3.28) @ 200 psi	No	No	289	17.23	7.56	12.15	31	PB102XL-X					
	Yes	No						PB102XL-0					
2nd Stage: 10 (0.16) @ 10,000 psi	Yes	Yes (***)						PB102XL-1 ***					
1st Stage: 200 (3.28) @ 200 psi	No	No						289	17.23	7.56	12.15	33	PB102XLP-X
	Yes	No											PB102XLP-0
2nd Stage: 10 (0.16) @ 10,000 psi	Yes	Yes (***)											PB102XLP-1 ***
1st Stage: 200 (3.28) @ 200 psi	No	No	289	17.23	7.56	14.11	32						PB102XLR-X
	Yes	No											PB102XLR-0
2nd Stage: 10 (0.16) @ 10,000 psi	Yes	Yes (***)											PB102XLR-1 ***
1st Stage: 200 (3.28) @ 200 psi	No	No						289	17.23	7.56	12.15	31	PB102XLA-X
	Yes	No											PB102XLA-0
2nd Stage: 10 (0.16) @ 10,000 psi	Yes	Yes (***)											PB102XLA-1 ***
1st Stage: 200 (3.28) @ 200 psi	No	No	289	17.23	7.56	12.15	31						PB102XL-CP-X
	Yes	No											PB102XL-CP-0
2nd Stage: 10 (0.16) @ 10,000 psi	Yes	Yes (***)											PB102XL-CP-1 ***
1st Stage: 200 (3.28) @ 200 psi	No	No						289	17.23	7.56	14.79	32	PB104XL-X
	Yes	No											PB104XL-0
2nd Stage: 10 (0.16) @ 10,000 psi	Yes	Yes (***)											PB104XL-1 ***

(\*\*\*) For plug type selection please use (-1 for US, -2 for EU, -3 for UK).  
Example PB102-1 for a US style plug / PB102-3 for a UK style plug

Model Shown:  
**PE104, PR104**



Pumps

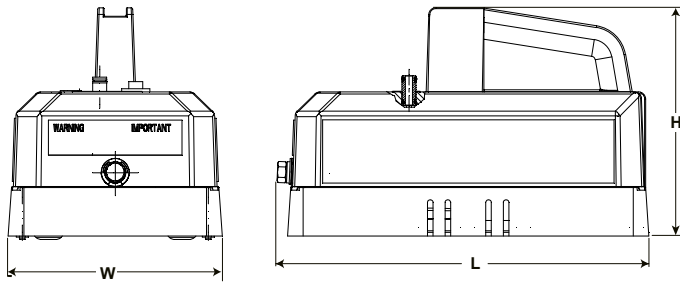

**Features**

**HIGH-PERFORMANCE IN A COMPACT PACKAGE. ELECTRIC AND BATTERY POWERED MODELS FOR POWERING TOOLS AND CYLINDERS UP TO 25 TON.**

- Portable power source for hydraulic cylinders and tools.
- Permanent magnet motor starts easily under load, even with reduced voltage conditions.
- Battery-operated models have 2,4 m power cord with alligator clips to connect to any 12VDC battery.
- Optional rechargeable battery pack with shoulder strap for maximum portability.
- Pump typically delivers 15 minutes of continuous operation at 700 bar on a single battery.
- Pump can be operated in any position.
- 24VDC hand and foot switches available for all AC powered models.
- High-impact housing with flame-retardant construction.
- Base mounting holes for fixed installations.
- CSA rated for intermittent duty.

**Performance Specifications**

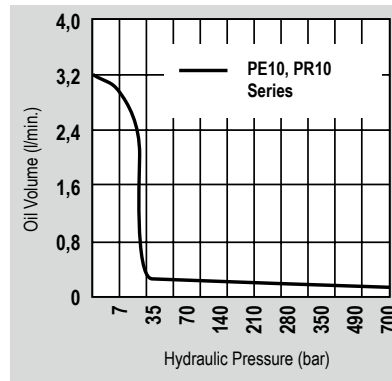

**Technical Dimensions**

Order No.	Max. Pressure Output (bar)	dBA at Idle and 700 (bar)	Oil Del. (l/min. @)		Overall Dimensions			Prod. Wt. with Oil (kg)
			0 (bar)	700 (bar)	Length (mm)	Width (mm)	Height (mm)	
PE10 Series	700	68-74*	1,9	0,16	330	197	203	9,1
PR10 Series								

\* Measured at 0,9 m distance, all sides.

► **Accessories**



**BP212VQ** – Optional 12VDC battery pack. Includes sealed lead acid battery, 115V charger, 1,2 m cord, carrying case and shoulder strap. Wt., 8 kg

**RC12V** – Replacement 1,2 m. battery cord only. Wt., 0,2 kg

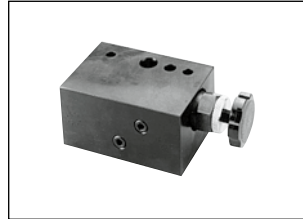

**9560** – Pressure regulator. Adjustable from 7 to 700 bar. All mounting hardware included. Wt., 1,4 kg.

**25017** – Remote hand control with 3,1 m cord. Wt., 0,4 kg.



**251660** – Foot switch with 3,1 m cord. Single pole, double throw, 15 amp @ 125-250V. Wt., 0,5 kg.

**NOTE:** PR10 rechargeable model is equipped with 2,4 m cord with alligator clips. Order optional battery pack (No. BP212VQ) or use with any 12VDC battery.

**NOTE:** Amp draw at 700 bar – 6 amp at 115V, 3 amp at 230V, and 35 amp at 12VDC.

► **The Quarter Horse pump has a maximum operating pressure of 700 bar, which handles a wide variety of hand-held hydraulic tools.**



► **Ordering Information**

Order No.	For Use With Cylinder Type	Description	Valve Type	Valve No.	Valve Function	Control Switch	Motor	Reservoir Usable Oil Cap. (l)
PE102-E220	Single-Acting	Base model pump with 0,19 kW motor. Bladder type reservoir, 110 volt power required.	2-Way/ Auto. Dump	9561	Advance Return (Auto.)*	Rocker Type off, Momentary on	0,19 kW, 220/230V 50/60 Hz, Single Phase	1
PE102A-E220	Single-Acting	PE102-E220, except has automatic dump valve.	Auto. Dump	9562	Advance Return**	Rocker Type off, Momentary on	0,19 kW, 220/230V 50/60 Hz, Single Phase	1
PE102-220	Single-Acting	PE102, except requires 220 volt.	2-Way/ Auto. Dump	9561	Advance Return (Auto.)*	Rocker Type off, Momentary on	0,19 kW, 220/230V 50/60 Hz, Single Phase	1
PE102A-220	Single-Acting	PE102A, except requires 220 volt.	Auto. Dump	9562	Advance Return**	Rocker Type off, Momentary on	0,19 kW, 220/230V 50/60 Hz, Single Phase	1
PR102	Single-Acting	PE102, except requires 12 volt DC.	2-Way/ Auto. Dump	9561	Advance Return (Auto.)*	Rocker Type off, Momentary on	0,19 kW, 12V†	1
PR102A	Single-Acting	PE102A, except requires 12 volt DC.	Auto. Dump	9562	Advance Return**	Rocker Type off, Momentary on	0,19 kW, 12V†	1
PE104	Single-Acting, Double-Acting	"Base model pump has 4-way valve for operating double-acting systems. 110 volt power required."	4-Way	9563	Advance Hold Return	Rocker Type off, Momentary on	0,19 kW, 220/230V 50/60 Hz, Single Phase	1
PE104-E220	Single-Acting, Double-Acting	PE104, except requires 220 volt.	4-Way	9563	Advance Hold Return	Rocker Type off, Momentary on	0,19 kW, 220/230V 50/60 Hz, Single Phase	1
PR104	Single-Acting, Double-Acting	PE104, except requires 12 volt DC.	4-Way	9563	Advance Hold Return	Rocker Type off, Momentary on	0,19 kW, 12V†	1

\* Advance position holds pressure with motor shut-off. Return position advances cylinder with motor running and returns cylinder with motor shut-off.

\*\* Cylinder advances with motor running and automatically returns with motor shut-off.

† Comes with an 8 ft. alligator clip cord for 12VDC use.

Model Shown:  
**PE172-E220**



Pumps



**Features**

**FOR MAINTENANCE AND CONSTRUCTION APPLICATIONS.**

- For use with single or double-acting cylinders at operating pressure up to 700 bar.
- Equipped with 0,37 kW, 2850 rpm, single-phase, thermal protected induction motor; 3 m remote control cord (PE172S has 7,6 m cord)
- Low amperage draw; small generators and low amperage circuits can be use as power source.
- Extremely quiet noise level (67-81 dBA).
- Starts under full load for intermittent duty.

**Hydraulic Hoses**

Heavy-duty and thermo plastic hydraulic hoses to meet your requirements and safety factor.  
**Refer to the accessories section for details.**



**Performance Specifications**

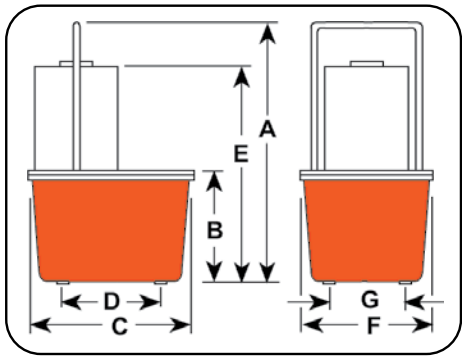
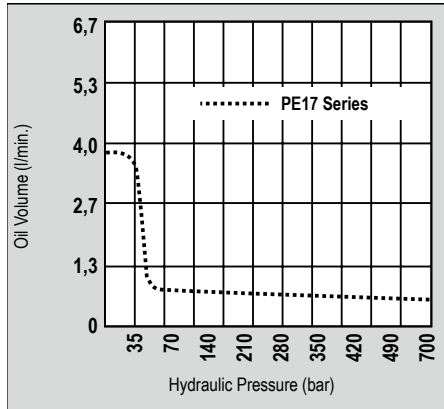

**Technical Dimensions**

Order No.	A	B	C	D	E	F	G	Max. Pressure Output (bar)	rpm	dBA at Idle and 700 (bar)	Amp Draw 220 V - at 700 (bar)	Oil Del. (l/min. @)				Prod. Wt. with Oil (kg)
	(mm)	(mm)	(mm)	(mm)	(mm)	(mm)	(mm)					0 (bar)	7 (bar)	350 (bar)	700 (bar)	
PE17 Series	470	178	289	181	378	235	130	700	2800	67/81*	5	3,9	2,5	0,3	0,2	20,4
PE17M Series	460	168	292	—	368	241	—	700	2800	67/81*	5	3,9	2,5	0,3	0,2	24,0

\* Measured at 0,9 m distance, all sides

**Ordering Information**

For Use With Cylinder Type	Description	Order No.	Valve Type	Valve No.	Valve Function	Control Switch	Motor	Reservoir Usable Oil Cap. (l)
Single-Acting	Base model pump with 0,37 kW pump with 7,6 liter thermoplastic reservoir. Non CE	<b>PE172-50-220</b>	2-Way	9517	Advance Return (Auto†)	Remote Motor Control (3,1 m) on/off	0,37 kW, 220V 50/60 Hz, Single Phase	4,72
Single-Acting	PE172-50-220, Non CE except has 9,5 liter steel reservoir.	<b>PE172M-50-220</b>	2-Way	9517	Advance Return (Auto†)	Remote Motor Control (3,1 m) on/off	0,37 kW, 220V 50/60 Hz, Single Phase	6
Single-Acting	PE172-50-220, Non CE except has solenoid operated valve.	<b>PE172S-50-220</b>	3-Way	9570	Advance Hold Return	Remote Motor & Valve (7,6 m)	0,37 kW, 220V 50/60 Hz, Single Phase	4,72
Single-Acting	PE172S-50-220, Non CE except has steel reservoir.	<b>PE172SM-50-220</b>	3-Way	9570	Advance Hold Return	Remote Motor & Valve (7,6 m)	0,37 kW, 220V 50/60 Hz, Single Phase	6
Single-Acting	Best suited for crimping, punching, pressing. Not for lifting. Thermoplastic reservoir.	<b>PE172A-50-220<sup>∞</sup></b>	Auto./Dump Manifold	45554	Advance Return	Remote Motor Control (3,1 m) on/off	0,37 kW, 220V 50/60 Hz, Single Phase	4,72
Single-Acting	PE172A-50-220, Non CE except has steel reservoir.	<b>PE172AM-50-220<sup>∞</sup></b>	Auto./Dump Manifold	45554	Advance Return	Remote Motor Control (3,1 m) on/off	0,37 kW, 220V 50/60 Hz, Single Phase	6
Single-Acting	0,37 kW pump with 7,6 liter thermoplastic reservoir. Meets CE requirements	<b>PE172-E220</b>	2-Way	9517	Advance Return (Auto†)	Remote Motor Control (3,1 m) on/off	0,37 kW, 220V 50/60 Hz, Single Phase	4,72
Single-Acting	PE172-E220, except has 9,5 liter steel reservoir. Meets CE requirements	<b>PE172M-E220</b>	2-Way	9517	Advance Return (Auto†)	Remote Motor Control (3,1 m) on/off	0,37 kW, 220V 50/60 Hz, Single Phase	6
Single-Acting	PE172-E220, except has solenoid operated valve. Meets CE requirements	<b>PE172S-E220</b>	3-Way	9570	Advance Hold Return	Remote Motor & Valve (3,1 m)	0,37 kW, 220V 50 Hz, Single Phase	4,72
Single-Acting	PE172-E220, except has steel reservoir. Meets CE requirements	<b>PE172SM-E220</b>	3-Way	9570	Advance Hold Return	Remote Motor & Valve (3,1 m)	0,37 kW, 220V 50 Hz, Single Phase	6
Single-Acting	Best suited for crimping, punching, pressing. Not for lifting. Thermoplastic reservoir. Meets CE requirements	<b>PE172A-E220<sup>∞</sup></b>	Auto./Dump Manifold	4554	Advance Return	Remote Motor Control (3,1 m) on/off	0,37 kW, 220V 50 Hz, Single Phase	4,72
Single-Acting	PE172A-E220, except has steel reservoir. Meets CE requirements	<b>PE172AM-E220<sup>∞</sup></b>	Auto./Dump Manifold	4554	Advance Return	Remote Motor Control (3,1 m) on/off	0,37 kW, 220V 50 Hz, Single Phase	6
Single/ Double-Acting	PE172-50-220, Non CE except has 9500 double-acting valve.	<b>PE174-50-220</b>	4-Way	9500	Advance Hold Return*	Remote Motor Control (3,1 m) on/off	0,37 kW, 220V 50 Hz, Single Phase	4,72
Single/ Double-Acting	PE174-50-220, Non CE except has steel reservoir.	<b>PE174M-50-220</b>	4-Way	9500	Advance Hold Return*	Remote Motor Control (3,1 m) on/off	0,37 kW, 220V 50 Hz, Single Phase	6
Single/ Double-Acting	PE172-E220, except has 9500 double-acting valve. Meets CE requirements	<b>PE174-E220</b>	4-Way	9500	Advance Hold Return*	Remote Motor Control (3,1 m) on/off	0,37 kW, 220V 50 Hz, Single Phase	4,72
Single/ Double-Acting	PE174-E220, except has steel. Meets CE requirements	<b>PE174M-E220</b>	4-Way	9500	Advance Hold Return*	Remote Motor Control (3,1 m) on/off	0,37 kW, 220V 50 Hz, Single Phase	6

\* Advance position holds pressure with motor shut-off.

† Advance position holds pressure with motor shut-off. Return position advances cylinder with motor running and returns cylinder with motor shut-off.

∞ Not to be used for lifting.

‡ Some Power Team pumps are available in special configurations not listed in this catalog. For your special requirements please consult your local distributor or the Power Team factory.

**NOTE:** Usable oil is calculated with the oil fill at the recommended level of 38 mm below reservoir cover plate.

**NOTE:** Contact Factory for special 12VDC version for service vehicles

Also available in E110 (meets CE requirement)

Model Shown:

**PE182, PE183-2, PE183C**

Pumps



## Features

**IDEAL FOR USE WITH SMALL HYDRAULIC POWER TOOLS.**

- Vanguard Jr.® pumps provide two-speed high-performance in a light-weight, compact package.
- Gauge port provided on pump. Metal reservoir on all models.
- Equipped with at 0,37 kW, 220V, 60/50 Hz single-phase motor that starts under load, even at reduced voltage.
- Low amperage draw permits use with smaller generators and low amperage circuits.
- All pumps have a 3,1 m remote control (PE183C has 7,6 m remote control).
- Noise level of 85-90 dBA.
- CSA rated for intermittent duty.
- Non CE.

## Ordering Information

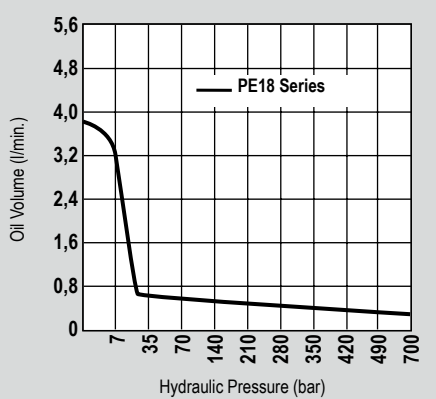

## For operating hydraulic crimping, cutting or other tools:

- **PE183C** - For crimping or pressing applications. Has special electrical circuitry to pulse/advance, hold at full pressure, build to a predetermined pressure, release and reset circuit. Features separate emergency return switch.
- **PE184C** - Allows operator to alternately operate a spring-return cutting and/or crimping tool without disconnecting either tool. Select port connection with manual 4-way valve, start pump with remote control hand switch and extend connected tool. When hand switch is switched to off, pump stops and automatic valve opens, allowing tool to return. In center (neutral) position, manual control valve holds tool in position at time valve is shifted.

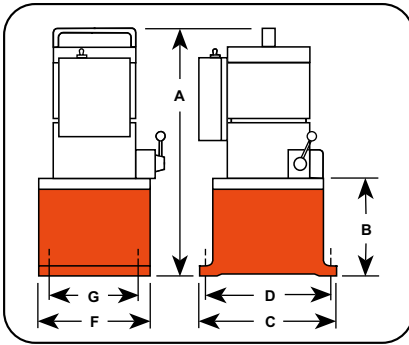

**Technical Dimensions**

Order No.	A (mm)	B (mm)	C (mm)	D (mm)	F (mm)	G (mm)	Max. Pressure Output (bar)	rpm	dBA at Idle and 700 (bar)	Amp Draw 220V at 700 (A)	Oil Del. (l/min. @) †				Prod. Wt. with Oil (kg)
											0 (bar)	7 (bar)	350 (bar)	700 (bar)	
PE182	406	121	203	181	152	130	700	12000	85/90**	10,2	3,7	3,0	0,4	0,3	13,6
PE183	406	121	203	181	152	130	700	12000	85/90**	10,2	3,7	3,0	0,4	0,3	13,6
PE183A	406	121	203	181	152	130	700	12000	85/90**	10,2	3,7	3,0	0,4	0,3	13,6
PE184	406	121	203	181	152	130	700	12000	85/90**	10,2	3,7	3,0	0,4	0,3	13,6
PE183-2*	470	184	292	254	241	203	700	12000	85/90**	10,2	3,7	3,0	0,4	0,3	19,0
PE184-2*	470	184	292	254	241	203	700	12000	85/90**	10,2	3,7	3,0	0,4	0,3	19,0
PE183C ††	406	121	203	181	152	130	700	12000	85/90**	10,2	3,7	3,0	0,4	0,3	13,6
PE184C ††	406	121	203	181	152	130	700	12000	85/90**	10,2	3,7	3,0	0,4	0,3	13,6

\* 9,5 l reservoir.

\*\* Measured at 3 ft. distance, all sides.

† Typical delivery. Actual flow will vary with field conditions.

†† Special application pumps for cutting, crimping or pressing.

**Performance Specifications**

For Use With Cylinder Type	Description	Order No.	Valve Type	Valve Function	Control Switch	Motor	Reservoir Usable Oil Cap. (L)
Single-Acting	Base model pump has 0,37 kW pump with 2-Way valve and 1,9 liter reservoir.	PE182	2-Way	Advance Return†	Remote Motor Control (3,1 m) on/off	0,37 kW, 110/115V** 50/60 Hz, A.C., Single Phase	1,7
Single-Acting	PE182, except has 3-way valve.	PE183	3-Way	Advance Hold Return	Remote Motor Control (3,1 m) on/off	0,37 kW, 110/115V** 50/60 Hz, A.C., Single Phase	1,7
Single-Acting	PE183, except has 2 gallon reservoir.	PE183-2	3-Way	Advance Hold Return	Remote Control (3,1 m)	0,37 kW, 110/115V** 50/60 Hz, A.C., Single Phase	8,4 ††
Single-Acting	PE183, except has "dump valve".	PE183A <sup>∞</sup>	Auto./Dump Pump	Advance Return	Remote (3,1 m)	0,37 kW, 110/115V** 50/60 Hz, A.C., Single Phase	1,7
Single-Acting	Special crimping pump.	PE183C <sup>∞</sup>	Special, for crimping only	Advance Hold Return†	Remote Motor Control (7,6 m) on/off	0,37 kW, 110/115V** 50/60 Hz, A.C., Single Phase	1,7
Single-Acting/ Double-Acting	Base model pump has 0,37 kW pump for double-acting systems with 1,9 liter reservoir.	PE184	4-Way	Advance Hold Return	Remote Motor Control (3,1 m) on/off	0,37 kW, 110/115V** 50/60 Hz, A.C., Single Phase	1,7
Single-Acting/ Double-Acting	PE184, except with 9,5 liter reservoir.	PE184-2	4-Way	Advance Hold Return†	Remote Motor Control (3,1 m) on/off	0,37 kW, 110/115V** 50/60 Hz, A.C., Single Phase	8,4 ††
Single-Acting/ Double-Acting	Special crimping pump.	PE184C*	4-Way	Advance Return	Remote Control (3,1 m) on/off	0,37 kW, 110/115V** 50/60 Hz, A.C., Single Phase	1,7

\* Also for use with special single-acting cylinder applications.

\*\* Available with 220V, 60/50 Hz motor (to order, place suffix "50-220" behind pump order number). Specify voltage when ordering.

† Holds when motor is shut-off and valve is in "advance" position.

†† Pumps supplied with 7,6 l oil (usable oil is 5,7 l), will hold 9,5 l gallon when filled to within 38 mm below reservoir cover plate.

<sup>∞</sup> Not to be used for lifting.

Model Shown:

**PE213, PE214, PE214S**

Pumps



**Features**

**IDEAL FOR USE WITH SMALL MEDIUM HYDRAULIC POWER TOOLS.**

- Totally enclosed, fan cooled induction motor: 0,75 kW, 1725 rpm, 60 Hz, single-phase. Thermal overload protection.
- Remote control, with 3,1 m cord is standard on pumps with solenoid valves. Manual valve pumps have “Stop”, “Start” and “Run/Off/Pulse” switches.
- Pump controls are moisture and dust resistant.
- Motor drip cover with carrying handles and lifting lug.
- Low noise level of 70 dBA@700 bar.
- In the event of electrical interruption, pump shuts off and will not start up until operator presses the pump start button.
- Units with remote have a 24V control circuit that provides additional user/operator safety.
- CSA rated for intermittent duty.
- Non CE.

▶ PE21 series pump and RD5513 cylinder used in a special press that produces pharmaceutical-grade extracts for herbal medicines.



**Performance Specifications**

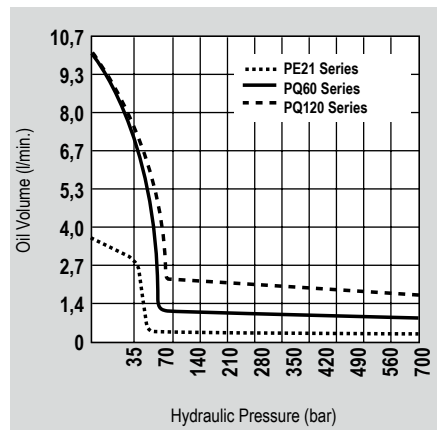



**Learn More - About Hydraulic Safety Insight**



Looking for great safety suggestions? Visit our Resource Section to get a better understanding of hydraulic and mechanical safety insights on what to look for when working around hydraulics



**Optional Cylinders**

Power Team offers a wide variety of single-acting, double-acting, lock nut, pancake and center hole cylinders to meet your requirements.

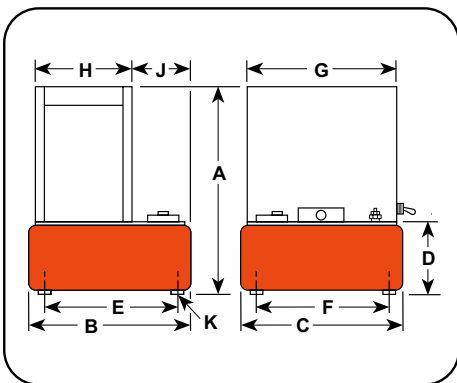

**Technical Dimensions**

Order No.	A	B	C	D	E	F	G	H	J	K**	Max. Pressure Output (bar)	rpm	dBA at Idle and 700 (bar)	Oil Del. (l/min. @)				Prod. Wt. † with Oil (kg)
	(mm)	(mm)	(mm)	(mm)	(mm)	(mm)	(mm)	(mm)	(mm)	(in.)				7 (bar)	70 (bar)	350 (bar)	700 (bar)	
<b>PE21 Series</b>	543	292	241	165	254	203	359	82,6	3.25	1/2-20 UNF	700	1437	70*	3,6	0,4	0,4	0,3	44,4 †

\*\* For 2" dia. swivel casters, order (4) No. 10494.

† Shipping weight with manual valve; add 14 kg for pump with solenoid valve.

**Ordering Information**

For Use With Cylinder Type	Description	Order No.	Valve Type	Valve No.	Valve Function	Max. Amp Draw @ 700 †† (bar)	Motor	Reservoir Usable Oil Cap. (L)
Single-Acting	0,75 kW pump with 9,5 liter reservoir and manual valve.	<b>PE213-50-220</b>	3-Way	9520*	Advance Hold Return	115V -15 amps 230V -7.5 amps	0,75 kW, 220 Volt 50 Hz, Single Phase	9,4
Single-Acting	PE213, except has solenoid operated remote valve.	<b>PE213S-50-220</b>	3-Way	9599†	Advance Hold Return	115V -15 amps 230V -7.5 amps	0,75 kW, 220 Volt 50 Hz, Single Phase	9,4
Double-Acting	0,75 kW pump with 9,5 liter reservoir and manual valve.	<b>PE214-50-220</b>	4-Way	9506*	Advance Hold Return	115V -15 amps 230V -7.5 amps	0,75 kW, 220 Volt 50 Hz, Single Phase	9,4
Double-Acting	PE214, except has solenoid operated remote valve.	<b>PE214S-50-220</b>	4-Way	9512†	Advance Hold Return	115V -15 amps 230V -7.5 amps	0,75 kW, 220 Volt 50 Hz, Single Phase	9,4

\* Manual valve. Pump is equipped with RUN/OFF/PULSE switch for control of motor.

† Solenoid valve. Pump is equipped with a remote control switch with 3,1 m cord.

†† Pre-wired at factory for this voltage. PE21 series available in 230V 60Hz or 220V 50Hz. Please specify when ordering. Example: for 60Hz order PE213-230; for 50Hz order PE213-50-220.

**NOTE:** Some Power Team pumps are available in special configurations not listed in this catalog. For your special requirements please consult your local distributor or the Power Team Customer Service.

Model Shown:

**PED253, PED254, PED254S**

Pumps



**Features**

**IDEAL FOR RUNNING MULTIPLE TOOLS OR CYLINDERS FROM ONE POWER UNIT. RECOMMENDED FOR CYLINDERS UP TO 75 TONS.**

- Two-speed pumps have the same low pressure and high pressure flows from both valves.
- Flows and pressures of each pump are independent.
- Delivers 4,8 l/min. of oil @ 7 bar and 0,4 l/min. @ 700 bar from each pump.
- 1,12 kW, 110/115V, 60 Hz induction motor, 3,1 m remote control and 19 l steel reservoir.
- Models available for operating single-acting or double-acting cylinders.
- Each power unit contains two separate pumps and two separate valves allowing operator to control multiple processes with one power unit.
- Both pumps on each power unit are equipped with an externally adjustable pressure relief valve.
- Not recommended for frequent starting and stopping.
- Non CE

**Performance Specifications**

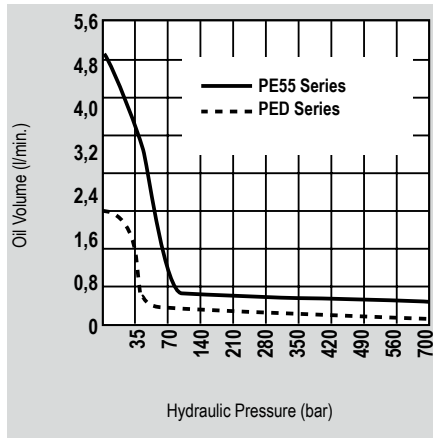



**4 Port Control Manifold**



For independent multiple-cylinder operation, feature needle valves for precise manual control. Designed for remote-mounted applications.

Ordering Information: **9644**



**Hydraulic Fluids**



For dependable performance of all your hydraulic pumps and cylinders. Power Team specialty blended oils contains foam suppressant additives and has a high viscosity index. Refer to the Accessories section for complete details

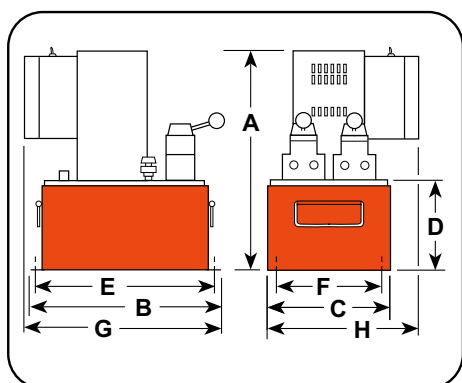

**Technical Dimensions**

Order No.	A	B	C	D	E	F	G	H	Max. Pressure Output	rpm	dBA at Idle and 700	Amp Draw 220V at 700	Oil Del. (l/min. @)				Prod. Wt. with Oil
	(mm)	(mm)	(mm)	(mm)	(mm)	(mm)	(mm)	(mm)					7	70	350	700	
<b>PED Series</b>	527	457	292	216	419	229	457	330	700	2874	87/85*	11	4,8	0,6	0,6	0,4	77

\*\* Amp draw at 700 bar, 230V 50/60 Hz is 15 Amps.

**Ordering Information**

For Use With Cylinder Type	Description	Order No.	Valve Type	Valve No.	Valve Function	Control Switch	Motor	Reservoir Usable Oil Cap. (cm <sup>3</sup> )	Reservoir Usable (l)
Single-Acting	1,12 kW pump with 19 liter reservoir. Valve has Posi-Check feature.	<b>PED253</b>	PED253-50-220	3-Way	9520	Advance Return	Remote Motor	1,12 kW, 220 V 50 Hz, Single Phase	16
Double-Acting	1,2 kW pump with 19 liter reservoir. Valve has Posi-Check feature.	<b>PED254</b>	PED254-50-220	4-Way	9506	Advance Hold Return	Remote Motor	1,12 kW, 220 V 50 Hz, Single Phase	16
Double-Acting	PED254, expect has solenoid operated remote valve.	<b>PED254S</b>	PED254S-50-220	4-Way	9513	Advance Hold Return	Remote Control	1,12 kW, 220 V 50 Hz, Single Phase	16

NOTE: All remotes are 3,1 m long.

Model Shown:

**PE302S, PE302**

Pumps



## Features

### IDEAL FOR MAINTENANCE AND CONSTRUCTION APPLICATIONS

- Deliver a powerful punch to operate single-acting or double-acting cylinders.
- Integral roll cage protects pump from abuse.
- 0,75 kW, single-phase, permanent magnet motor.
- High-performance-to-weight ratio.
- Starts under full load even when voltage is reduced to 50% of nominal rating.
- Quiet operation: 82 dBA @ 700 bar and 87 dBA @ 0 bar.
- Remote controls and/or solenoid valves feature 24V controls.
- CSA rated for intermittent duty.
- Non CE



## PE30TWP



For Torque Wrench Pump Configurations, refer to the Tools Section.

## Performance Specifications

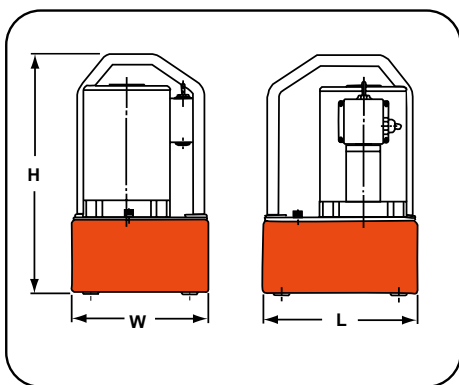
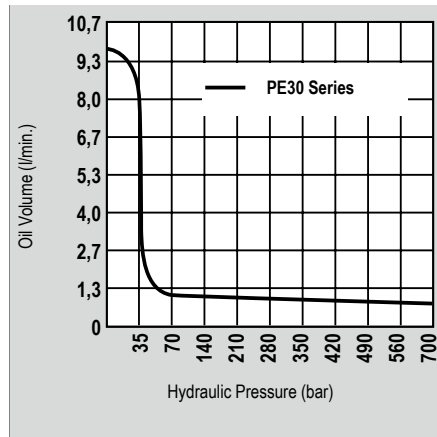

## Technical Dimensions

Order No.	Overall Dimensions			Max. Pressure Output (bar)	dBA at Idle and 700 (bar)	Amp Draw 220V at 700 (A)	Oil Del. (l/min. @)					Prod. Wt. with Oil (kg)
	Length	Width	Height				7	35	70	350	700	
	(mm)	(mm)	(mm)				(bar)	(bar)	(bar)	(bar)	(bar)	
PE30 Series with 4,7 liter reservoir	254	229	406	700	87/82	7	4,8	3,2	0,7	0,6	0,5	18,6
PE30 Series with 7,6 liter reservoir	343	241	419	700	87/82	7	4,8	3,2	0,7	0,6	0,5	22,2

**Ordering Information**

For Use With Cylinder Type	Description	Order No.	Valve Type	Valve No.	Valve Function	Control Switch	Motor (4,000 rpm)	Reservoir Usable Oil Cap. (l)
Single-Acting	Base model 0,75 kW pump with 4,7 liter reservoir and 2 position valve.	<b>PE302-220<sup>∞</sup></b>	3-Way, 2 Position	9584	Hold Advance Return	On/Off Pulse Switch	0,75 kW 220/230 V, 50 Hz, Single Phase	4,5 **
Single-Acting	PE302-220, except has 6,6 liter reservoir.	<b>PE302-2-220</b>	3-Way, 2 Position	9584	Hold Advance Return	On/Off Pulse Switch	0,75 kW 220/230 V, 50 Hz, Single Phase	6,1 ***
Single-Acting	PE302-220, except has remote motor control.	<b>PE302R-220</b>	3-Way, 2 Position	9584	Hold Advance Return	Remote Motor Control (3,1 m)	0,75 kW 220/230 V, 50 Hz, Single Phase	4,5 **
Single-Acting	PE302R-220, except has 6,6 liter reservoir.	<b>PE302R-2-220</b>	3-Way, 2 Position	9584	Hold Advance Return	Remote Motor Control (3,1 m)	0,75 kW 220/230 V, 50 Hz, Single Phase	6,1 ***
Single-Acting	PE302R-220, except also has solenoid operated remote valve.	<b>PE302S-220</b>	3-Way, 2 Position	9570	Hold Advance Return	Remote Motor & Valve (3,1 m)	0,75 kW 220/230 V, 50 Hz, Single Phase	4,5 **
Single-Acting	PE302S-220, except has 6,6 liter reservoir.	<b>PE302S-2-220</b>	3-Way, 2 Position	9570	Hold Advance Return	Remote Motor & Valve (3,1 m)	0,75 kW 220/230 V, 50 Hz, Single Phase	6,1 ***
Single-Acting	PE302-220, except has "Auto Dump" valve	<b>PE302A-220<sup>∞</sup></b>	Auto Dump	9610	Automatic Pilot Operation	Remote Motor Control (3,1 m)	0,75 kW 220/230 V, 50 Hz, Single Phase	4,5 **
Single-Acting	Base model 0,75 kW pump with 4,7 liter reservoir and 3 position valve.	<b>PE303-220</b>	3-Way, 3 Position	9520*	Advance Hold Return	On/Off Pulse Switch	0,75 kW 220/230 V, 50 Hz, Single Phase	4,5 **
Single-Acting	PE303-220, except has 6,6 liter reservoir.	<b>PE303-2-220</b>	3-Way, 3 Position	9520*	Advance Hold Return	On/Off Pulse Switch	0,75 kW 220/230 V, 50 Hz, Single Phase	6,1 ***
Single-Acting	PE303-220, except has remote motor control.	<b>PE303R-220</b>	3-Way, 3 Position	9520*	Advance Hold Return	Remote Motor Control (3,1 m)	0,75 kW 220/230 V, 50 Hz, Single Phase	4,5 **
Single-Acting	PE303R-220, except has 6,6 liter reservoir.	<b>PE303R-2-220</b>	3-Way, 3 Position	9520*	Advance Hold Return	Remote Motor Control (3,1 m)	0,75 kW 220/230 V, 50 Hz, Single Phase	6,1 ***
Double-Acting	Base model 0,75 kW pump with 4,7 liter reservoir and 4-way valve for double-acting systems	<b>PE304-220</b>	4-Way, 3 Position Tandem Center	9506*	Advance Hold Return	On/Off Pulse Switch	0,75 kW 220/230 V, 50 Hz, Single Phase	4,5 **
Double-Acting	PE304-220, except has 6,6 liter reservoir.	<b>PE304-2-220</b>	4-Way, 3 Position Tandem Center	9506*	Advance Hold Return	On/Off Pulse Switch	0,75 kW 220/230 V, 50 Hz, Single Phase	6,1 ***
Double-Acting	PE304-220, except has remote motor control.	<b>PE304R-220</b>	4-Way, 3 Position Tandem Center	9506*	Advance Hold Return	Remote Motor Control (3,1 m)	0,75 kW 220/230 V, 50 Hz, Single Phase	4,5 **
Double-Acting	PE304R-220, except has 6,6 liter reservoir.	<b>PE304R-2-220</b>	4-Way, 3 Position Tandem Center	9506*	Advance Hold Return	Remote Motor Control (3,1 m)	0,75 kW 220/230 V, 50 Hz, Single Phase	6,1 ***

\* Posi-Check® valve design, Posi-Check® guards against pressure loss when valve is shifted from "advance" to "hold" position.

\*\* Shipped with 3,8 l of oil (3,4 l, 210 usable).

\*\*\* Shipped with 7,6 l of oil.

<sup>∞</sup> Not to be used for lifting applications. Best suited for crimping, pressing & punching applications.

NOTE: For 220/230V, 50/60 Hz. add suffix "- 220" (example PE302-220).

Pumps

Model Shown:  
**PE462-E220**



Pumps

▶ PE46 series pump and RD5513 cylinder used in a special press that produces pharmaceutical-grade extracts for herbal medicines.



## Features

**BEST SUITED FOR UNDER-THE-ROOF MAINTENANCE AND PRODUCTION APPLICATIONS.**

- Two-speed high-performance pump.
- For use with single or double-acting cylinders at operating pressures up to 700 bar.
- Equipped with a 1,12 kW, 2875 rpm single-phase, 50 Hz thermal protected induction motor that starts under full load. Noise level of 77-81 dBA.
- All equipped with a 3,1 m remote control except PE462S which has a 7,6 m remote control.
- 24V control circuit on all units with remote control.
- CSA rated for intermittent duty.



## Hydraulic Hoses

Heavy-duty and thermo plastic hydraulic hoses to meet your requirements and safety factor.

Refer to accessories section for details



## Hydraulic Fluids

For dependable performance of all your hydraulic pumps and cylinders. Power Team specialty blended oils contains foam suppressant additives and has a high viscosity index. Refer to the Accessories section for complete details



## Performance Specifications

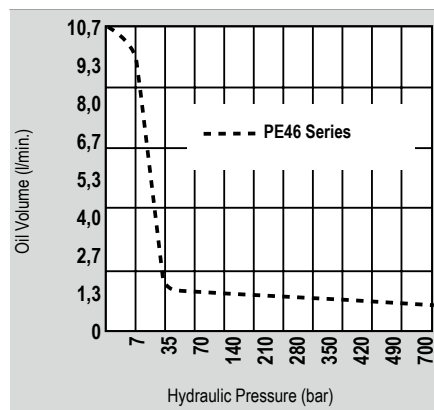

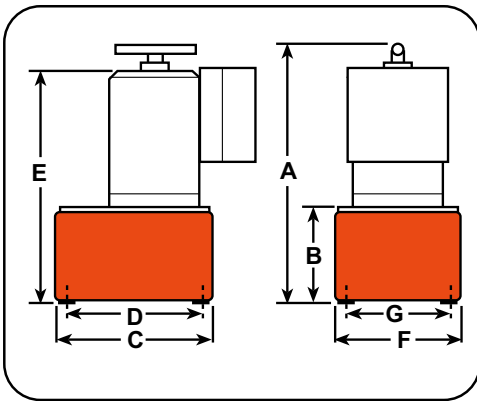

**Technical Dimensions**

Order No.	A	B	C	D	E	F	G	Max. Pressure Output (bar)	rpm	dBA at Idle and 700 (bar)	Amp Draw 220V at 700 (A)	Oil Del. (l/min. @) †				Prod. Wt. with Oil (kg)
	(mm)	(mm)	(mm)	(mm)	(mm)	(mm)	(mm)					7 (bar)	70 (bar)	350 (bar)	700 (bar)	
PE46 Series	499	173	292	254	378	241	203	700	2,875	77/81*	13**	6,7	6,0	0,7	0,6	35,8
PE46-E220	499	173	292	254	378	241	203	700	2,875	77/81*	13**	6,7	6,0	0,7	0,6	41,3

\* Measured at 0,9 m. distance, all sides.

\*\* Requires 20 amp circuit.

† Typical delivery. Actual flow will vary with field conditions.

**Ordering Information**

For Use With Cylinder Type	Description	Order No.	Valve Type	Valve No.	Valve Function	Control Switch ††	Motor	Reservoir ***Usable Oil Cap. (l)
Single-Acting	Base model 1,12 kW pump with 9,5 liter metal reservoir	PE462-50-220	3-Way	9584	Advance Return†	Remote Motor Control (3,1 m) on/off	1,12 kW, 220 V* 50 Hz, Single Phase	9,4
Single-Acting	PE462-50-220, except has solenoid valve	PE462S-50-220	3-Way	9570	Advance Return**	Remote Motor Valve (7,6 m)	1,12 kW, 220 V* 50 Hz, Single Phase	9,4
Single-Acting	PE462-50-220, except has "dump valve"	PE462A-50-220 <sup>∞</sup>	"Auto/ Dump 3-Way "	9610	Advance Return	Remote Motor Control (3,1 m) on/off	1,12 kW, 220 V* 50 Hz, Single Phase	9,4
Single-Acting	1,12 kW pump with 9,5 liter metal reservoir Meets CE requirement	PE462-E220	3-Way	9584	Advance Return†	Remote Motor Control (3,1 m) on/off	1,12 kW, 220 V* 50 Hz, Single Phase	9,4
Single-Acting	PE462-50-220, except has solenoid valve Meets CE requirement	PE462S-E220	3-Way	9570	Advance Return**	Remote Motor Valve (7,6 m)	1,12 kW, 220 V* 50 Hz, Single Phase	9,4
Single-Acting	PE462-50-220, except has "dump valve". Meets CE requirement	PE462A-E220	"Auto/ Dump 3-Way "	9610	Advance Return	Remote Motor Control (3,1 m) on/off	1,12 kW, 220 V* 50 Hz, Single Phase	9,4
Double-Acting/ Multi-Single Acting	PE462-50-220, except has 9500 double-acting valve.	PE464-50-220	4-Way	9500	Advance Hold Return†	Remote Motor Control (3,1 m) on/off	1,12 kW, 220 V* 50 Hz, Single Phase	9,4
Double-Acting/ Multi-Single Acting	Same as PE464-50-220 Meets CE requirement	PE464-E220	4-Way	9500	Advance Hold Return†	Remote Motor Control (3,1 m) on/off	1,12 kW, 220 V* 50 Hz, Single Phase	9,4
Double-Acting/ Multi-Single Acting	PE462S-50-220 Meets CE requirement	PE464S-E220	3/4-Way	9592	Advance Return**	Remote Motor/Valve (3,1 m)	1,12 kW, 220 V* 50 Hz, Single Phase	9,4
Double-Acting/ Multi-Single Acting	PE462S-50-220, except has 9592 double-acting valve	PE464S-50-220	3/4-Way	9592	Advance Return**	Remote Motor/Valve (3,1 m)	1,12 kW, 220 V* 50 Hz, Single Phase	9,4

\* Available with 220V 50 Hz motor (to order, place suffix "50-220" behind pump order number). Specify voltage when ordering.

\*\* Advance position holds pressure with motor shut-off.

\*\*\* Usable oil is calculated with the oil fill at the recommended level of 1.50" below reservoir cover plate.

† Advance position holds pressure with motor shut-off. Return position returns cylinder.

†† The remote motor control switch on PE46 series pumps is 24V.

∞ Not to be used for lifting. When pump is shut-off, oil returns to reservoir.

Model Shown:  
**PE55-E220**



Pumps

**Features**

**INDUSTRY LEADING HEAVY-DUTY PUMP FOR MULTIPLE APPLICATIONS**

- 0,84 kW, 12000 rpm, 220V, 50/60 Hz universal motor. Draws 25 amps at full load, starts at reduced voltage.
- True unloading valve achieves greater pump efficiency, allowing higher flow at maximum pressure.
- Reservoirs available in sizes up to 38 l, refer to pump accessories page.
- Lightweight and portable. Best performance-to-weight ratio of all Power Team pumps.
- 3,1 m remote motor control.



**Torque Wrench Pumps**



For Torque Wrench Pump Configurations, refer to the Tools Section.

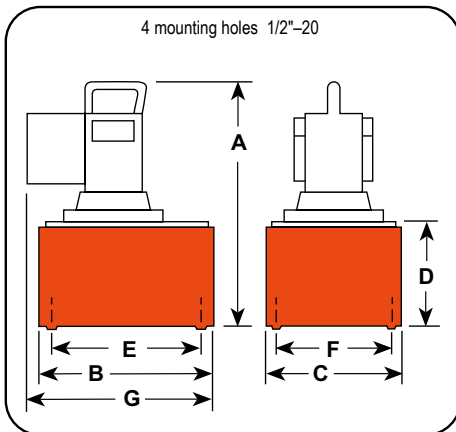

**Performance Specifications**

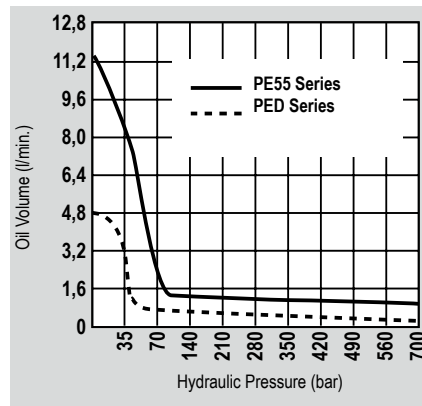

**Technical Dimensions**

Order No.	A	B	C	D	E	F	G	Max. Pressure Output (bar)	rpm	dBA at Idle and 700 (bar)	Amp Draw 230V at 700 (A)	Oil Del. (l/min. @)				Prod. Wt. with Oil (kg)
												0 (bar)	50 (bar)	350 (bar)	700 (bar)	
PE55 Series	464 (mm)	292 (mm)	241 (mm)	178 (mm)	254 (mm)	203 (mm)	356 (mm)	700	12000	90/89*	13	11,3 (bar)	7,1 (bar)	1,2 (bar)	0,9 (bar)	29,4
PE55-E220	520 (mm)	292 (mm)	241 (mm)	178 (mm)	254 (mm)	203 (mm)	391 (mm)	700	12000	90/89*	13	11,3 (bar)	7,1 (bar)	1,2 (bar)	0,9 (bar)	29,4

**Ordering Information**

For Use With Cylinder Type	Description	Order No. ***	Valve Type	Valve No.	Valve Function	Control Switch ††	Motor	Reservoir Usable Oil Cap. (l)
Single-Acting	Base model 0,84 kW pump with 9,5 liter reservoir, remote motor control	PE552-50-220	3-Way	9582	Advance Return**	Remote Motor	0,84 kW*, 220 V 50 Hz, Single Phase	8,4
Single-Acting	PE552-50-220, except also has solenoid operated remote valve	PE552S-50-220	3-Way	9570	Advance Hold Return	Remote Motor & Valve	0,84 kW*, 220 V 50 Hz, Single Phase	8,4
Single-Acting	PE552-50-220, except has Auto Dump valve	PE552A-50-220	Auto/Dump	9610	Advance Return	Remote Motor	0,84 kW*, 220 V 50 Hz, Single Phase	8,4
Single-Acting	0,84 kW pump with 9,5 liter reservoir. Valve has Posi-Check feature.	PE553-50-220	3-Way†	9520	Advance Hold Return	Remote Motor	0,84 kW*, 220 V 50 Hz, Single Phase	8,4
Single-Acting	Same as PE552-20-220, but meets also CE requirement	PE552-E220	3-Way	9584	Advance Return**	Remote Motor	0,84 kW*, 220 V 50 Hz, Single Phase	8,4
Single-Acting	Same as PE552S, but meets also CE requirement	PE552S-E220	3-Way	9570	Advance Return	Remote Motor & Valve	0,84 kW*, 220 V 50 Hz, Single Phase	8,4
Single-Acting	Same as PE552A-50-220, but meets also CE requirement	PE552A-E220 <sup>∞</sup>	Auto/Dump	9610	Advance Hold Return	Remote Motor	0,84 kW*, 220 V 50 Hz, Single Phase	8,4
Single-Acting	Same as PE553-50-220, but meets also CE requirement	PE553-E220	3-Way	9520	Advance Hold Return	Remote Motor	0,84 kW*, 220 V 50 Hz, Single Phase	8,4
Double-Acting	Base model 0,84 kW pump with 9,5 liter reservoir, and 4-way valve for double-acting systems	PE554-50-220	4-Way†	9506	Advance Hold Return	Remote Motor	0,84 kW*, 220 V 50 Hz, Single Phase	8,4
Double-Acting	Same as PE554-50-220 but meets also CE requirement	PE554-E220	4-Way†	9506	Advance Hold Return	Remote Motor	0,84 kW*, 220 V 50 Hz, Single Phase	8,4
Double-Acting	PE554-50-220, except has 9500 tandem center valve.	PE554T-50-220	4-Way	9500	Advance Hold Return	Remote Motor	0,84 kW*, 220 V 50 Hz, Single Phase	8,4
Double-Acting	For use with single-acting Spring Seat, Stressing Jack or double-acting cylinder.	PE554P-50-220	4-Way	9500	Advance Hold Return	Remote Motor	0,84 kW*, 220 V 50 Hz, Single Phase	8,4
Double-Acting	For use with single- or double-acting Power Seat, Stressing Jacks ONLY	PE554PT-50-220	4-Way	9628	Advance Hold Sequenced Return	Remote Motor	0,84 kW*, 220 V 50 Hz, Single Phase	8,4
Double-Acting	Pump suitable to run multiple spring return tools	PE554C-50-220	4-Way	9511 †††	Advance Hold Return	Remote Motor	0,84 kW*, 220 V 50 Hz, Single Phase	8,4
Double-Acting	Pump equipped with 3/4-Way solenoid valve.	PE554S-50-220	3/4-Way	9552	Advance Hold Return	Remote Motor & Valve	0,84 kW*, 220 V 50 Hz, Single Phase	8,4
Double-Acting	Pump suitable to run multiple Spring return cylinder Meets CE requirement	PE554C-E220	4-Way	9511 †††	Advance Hold Return	Remote Motor	0,84 kW*, 220 V 50 Hz, Single Phase	8,4
Double-Acting	Pump equipped with 3/4-way solenoid valve Meets CE requirement	PE554S-E220	3/4-Way	9552	Advance Hold Return	Remote Motor & Valve	0,84 kW*, 220 V 50 Hz, Single Phase	8,4

\* Pumps available with 115V, 50 Hz motors. Specify E110 when ordering.

\*\* Holds with motor shut-off.

† Valves have Posi-Check® feature.

†† All remotes are 3,1 m long.

††† Valving allows alternate and independent operation of two different spring return tools. Valve holds pressure only while valve is in "A" or "B" port position with pump motor shut-off.

∞ Not to be used for lifting.

Also available in E110 (meets CE requirement)

Model Shown:

**PE604T, PE604PT**

Pumps



▶ The PE60 used for pre-stressing application



## Features

**COMPACT, LIGHTWEIGHT PUMP. EXCELLENT CHOICE FOR RUGGED APPLICATIONS AND LOW VOLTAGE STARTING.**

- Pump offers long, trouble-free life in the most demanding work environments.
- For operating single or double-acting cylinders, or stressing jacks.
- Powered by 0,84 kW, 220V, 50/60 Hz single-phase motor. Starts under load, even at reduced voltages at construction sites.
- Optional fan-driven external oil cooler includes rollover guard.
- Insulated carrying handle.
- Integral 102 mm. fluid-filled pressure gauge with steel bezel complies with ASME B40.1 Grade A.
- Sealed 4,34 l (usable) reservoir. Reservoir drain port is standard.
- Oil level sight gauge for accurate oil level monitoring.
- External spin-on filter removes contaminants from circulating oil to maximize pump, valve and cylinder/ tool life.
- CSA rated for intermittent duty.
- Non CE.

## Performance Specifications

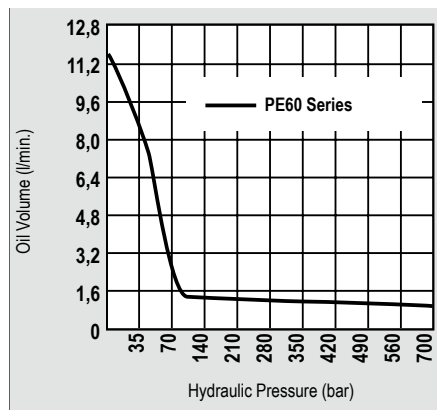



**Optional: Oil Cooler Kit**

For Use With:	Kit Order No.	Voltage	Wt. (kg)
PE604T or PE604PT	252511	115V	2,3
	252512	220V	2,3



**Hydraulic Fluids**



For dependable performance of all your hydraulic pumps and cylinders. Power Team specialty blended oils contains foam suppressant additives and has a high viscosity index. Refer to the Accessories section for complete details



**Learn More - About Hydraulic Safety Insight**



Looking for great safety suggestions? Visit our Resource Section to get a better understanding of hydraulic and mechanical safety insights on what to look for when working around hydraulics

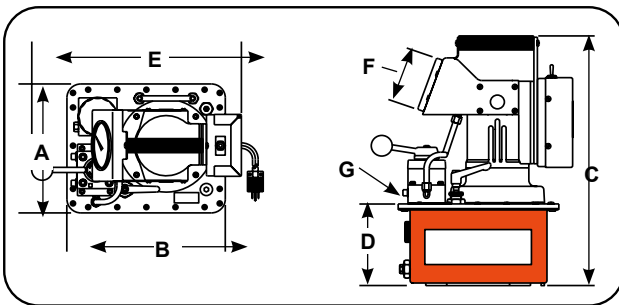

**Technical Dimensions**

Order No.	A	B	C	D	E	F	G	Max. Pressure Output (bar)	rpm	dBA at Idle and 700 (bar)	Amp Draw 220V at 700 (bar)	Oil Del. (l/min. @)				Prod. Wt. with Oil (kg)
	(mm)	(mm)	(mm)	(mm)	(mm)	(mm)	(mm)					0 (bar)	50 (bar)	350 (bar)	700 (bar)	
PE604T	263,5	301,6	457,2	152,4	381	101,6	3/8 NPTF	700	10.000	80/85*	13	11,3	7,1	1,2	0,9	27,2
PE604PT	263,5	301,6	457,2	152,4	381	101,6	3/8 NPTF	700	12.000	80/85*	13	11,3	7,1	1,2	0,9	27,2

NOTE: Unloading pressure is 70 bar.

**Ordering Information**

For Use With Cylinder Type	Description	Order No.	Valve Type	Valve No.	Valve Function	Control Switch	Motor	Reservoir Usable Oil Cap. (l)
Single-Acting, Spring Seat, Stressing Jack or Double-Acting	0,84 kW pump with 3,73 liter reservoir & valve for double-acting systems.	PE604T	4-Way/ 3 Position	9500	Advance Hold Return	On/Off Pulse	0,84 kW, 220 V 50 Hz, Single Phase	4,34
Single-Acting or Double-Acting Power Seat, Stressing Jacks Only	PE604T, except has special valve for post tensioning application only.	PE604PT	4-Way/ 3 Position	9628 Model C	Advance Hold Sequenced Return	On/Off Pulse	0,84 kW, 220 V 50 Hz, Single Phase	4,34

NOTE: Contact Factory for PE60 pump models with other control and valve options.

NOTE: For 220/230V, 50/60 Hz, single-phase models, add -220 suffix.

Model Shown:

**PQ603, PQ604, PQ604S**

Pumps



**Features**

**PUMP DESIGNED SPECIFICALLY FOR HEAVY-DUTY, EXTENDED CYCLE OPERATION.**

- For operating single or double-acting cylinders.
- Metal shroud keeps dirt and moisture out of motor and electrical components.
- Electrical shut-down feature prevents unintentional restarting of motor following an electrical service interruption.
- Internal relief valve limits pressure to 700 bar.
- External relief valve is adjustable from 70 to 700 bar.
- Pumps operate below maximum OSHA noise limitation (74-76 dBA).
- Start and operate under full load, even with voltage reduced by 10%.
- CSA rated for intermittent duty.
- Non CE.



**Hydraulic Fluids**



For dependable performance of all your hydraulic pumps and cylinders. Power Team specialty blended oils contains foam suppressant additives and has a high viscosity index. Refer to the Accessories section for complete details

**Hydraulic Machine Press Operation**



**Performance Specifications**

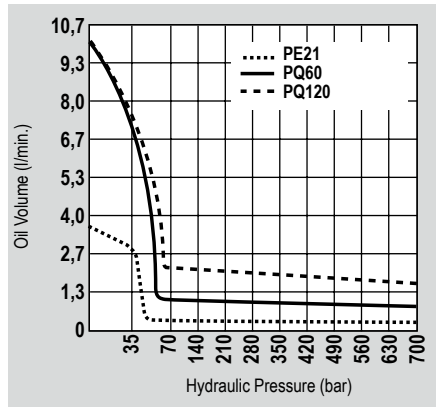



**Universal Pump Cart**



Mobilize your hydraulic pumps with the cart # PC200 - refer to the accessories section for details. Cart can be used with the following pumps; PA60, PA64, PA55/PE55, PE18, PE21, PQ60, PQ120, PG55 series and pumps with optional 5- and 10-gallon reservoirs; Nos. RP50, RP51, RP101 and RP103. (Pump not included)



**Optional: Swivel Casters**



Order No.	Description	Wt. (kg)
10494	2" dia. swivel casters (4 Required)	0,1

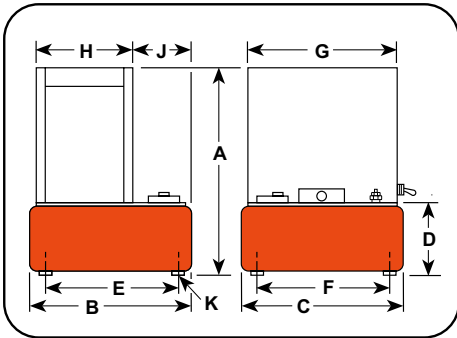

**Technical Dimensions**

Order No.	A	B	C	D	E	F	G	H	J	K	Max. Pressure Output (bar)	rpm	dBA at Idle and 700 (bar)	Oil Del. (l/min. @)				Prod. Wt. with Oil (kg)
	(mm)	(mm)	(mm)	(mm)	(mm)	(mm)	(mm)	(mm)	(mm)	(mm)				7 (bar)	70 (bar)	350 (bar)	700 (bar)	
PQ60 Series	638	362	394	184	308	338	373	237	122,2	1/2-20 UNF	700	1,437	74/76*	9,7	0,9	0,9	0,8	76,6**

\* Measured at 3 ft. distance, all sides.

\*\* Total weight with oil and 3-way solenoid valve. Subtract 4,5 kg to obtain weight of pump with manual valve.

**Ordering Information**

For Use With Cylinder Type	Description	Order No.	Valve Type	Valve No.	Valve Function	Max. Amp Draw @ 700 (bar)	Motor ††	Reservoir Usable Oil Cap. (l)
Single-Acting	1,49 kW pump with 21,6 liter reservoir and manual valve	PQ603	3-Way	9520*	Advance Hold Return	115V -22 amps 230V -11 amps	1,49 kW, 220 Volt 50 Hz, Single Phase	20
Single-Acting	PQ603, except has solenoid operated remote valve	PQ603S	3-Way	9599†	Advance Hold Return	115V -22 amps 230V -11 amps	1,49 kW, 220 Volt 50 Hz, Single Phase	20
Double-Acting	1,49 kW pump with 21,6 liter reservoir and manual valve	PQ604	4-Way	9506*	Advance Hold Return	115V -22 amps 230V -11 amps	1,49 kW, 220 Volt 50 Hz, Single Phase	20
Double-Acting	PQ604, except has solenoid operated remote valve.	PQ604S	4-Way	9512†	Advance Hold Return	115V -22 amps 230V -11 amps	1,49 kW, 220 Volt 50 Hz, Single Phase	20

\* Manual valve. Pump is equipped with RUN/OFF/PULSE switch for control of motor.

† Solenoid valve. Pump is equipped with a remote control switch with 3,1 m cord.

†† PQ60 series also available in 115V, 60 Hz or 220V, 50 Hz. Please specify when ordering. Example: for 60 Hz order PQ603-115; for 50 Hz order PQ603-50-220.

NOTE: Some Power Team pumps are available in special configurations not listed in this catalog. For your special requirements please consult your local distributor or the Power Team factory.

Model Shown:

**PQ1204S-E380**



Pumps

**Features**

**PUMP DESIGNED SPECIFICALLY FOR HEAVY-DUTY, EXTENDED CYCLE OPERATION.**

- Start and operate under full load, even with voltage reduced by 10%.
- Electrical shut-down feature prevents unintentional restarting of motor following an electrical service interruption.
- Internal relief valve limits pressure to 700 bar.
- External relief valve is adjustable from 70 to 700 bar.
- Pump pre-wired at factory with a 2,24 kW, 400V, 50 Hz, three-phase motor. Other electrical configurations are available. See ordering information on the following page.
- 24 volt control circuit on units with remote control for added user/operator safety.
- Thermal overload protection, motor starter and heater element supplied as **standard equipment**.

▶ **PQ series pump used to drive piers to lift and stabilize building foundation.**



▶ **Performance Specifications**

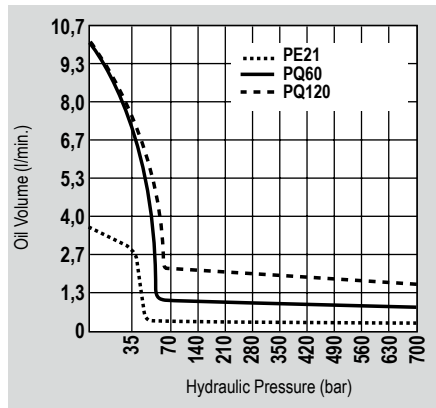



**Optional: Swivel Casters (4)**



Order No.	Description	Wt. (kg)
10494	2" dia. swivel casters	0,1



**Analog Gauges**



Improve your system visibility and safety by adding an inline hydraulic gauge to your circuit.

**9040E (63 mm)**  
**9052E (100 mm)**

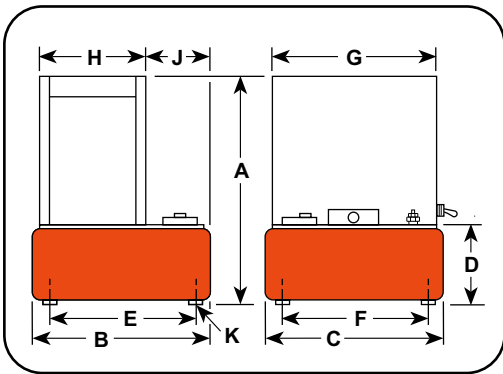

**Technical Dimensions**

Order No.	A	B	C	D	E	F	G	H	J	K	Max. Pressure Output (bar)	rpm	dBA at Idle and 700 (dBA)	Oil Del. (l/min. @)				Prod. Wt. ** with Oil (kg)
	(mm)	(mm)	(mm)	(mm)	(mm)	(mm)	(mm)	(mm)	(mm)	(mm)				0 (bar)	70 (bar)	350 (bar)	700 (bar)	
<b>PQ120 Series</b>	638	362	394	184	308	338	373	237	122	1/2-20 UNF	700	1437	73/78	9,7	2,1	1,7	1,6	74,3

\*\*Total weight with oil and 3-way solenoid valve. Subtract 4,5 kg to obtain weight of pump with manual valve.

**Ordering Information**

For Use With Cylinder Type	Description	Order No.	Valve Type	Valve No.	Valve Function	Max. Amp Draw @ 700 (bar)	Motor	Reservoir Usable Oil Cap. (l)
Single-Acting	2,24 kW pump with 21,6 liter reservoir and manual valve.	<b>PQ1203-E380</b>	3-Way	9520*	Advance Hold Return	230v - 12 amps 400v - 6 amps	2,24 kW, 400 Volt 50 Hz, 3 Phase	20
Single-Acting	PQ1203, except has solenoid operated remote valve.	<b>PQ1203S-E380</b>	3-Way	9599†	Advance Hold Return	230v - 12 amps 400v - 6 amps	2,24 kW, 400 Volt 50 Hz, 3 Phase	20
Double-Acting	2,24 kW pump with 21,6 liter reservoir and manual valve.	<b>PQ1204-E380</b>	4-Way	9506*	Advance Hold Return	230v - 12 amps 400v - 6 amps	2,24 kW, 400 Volt 50 Hz, 3 Phase	20
Double-Acting	PQ1204, except has solenoid operated remote valve.	<b>PQ1204S-E380</b>	4-Way	9512†	Advance Hold Return	230v - 12 amps 400v - 6 amps	2,24 kW, 400 Volt 50 Hz, 3 Phase	20

\* Manual valve. Pump is equipped with RUN/OFF/PULSE switch for control of motor.

† Solenoid valve. Pump is equipped with a remote control switch with 3,1 m cord.

Model Shown:  
**PE4004S**



Pumps

▶ **PE4004S pump and RD3006 cylinder used in a special press which repairs damaged chain links for the shipping industry.**

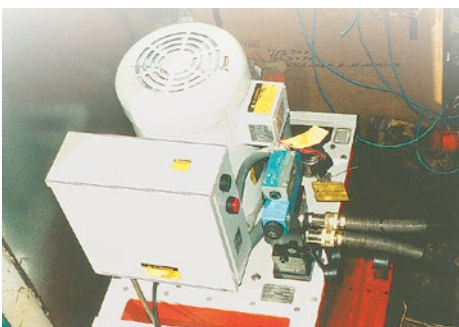

### ▶ Features

#### **PUMP DESIGNED SPECIFICALLY FOR HEAVY-DUTY, EXTENDED CYCLE OPERATION.**

- Two-speed high output pump delivers up to 16 l/min of oil.
- Low noise level of 73-80 dBA.
- Integral electrical shut-down feature prevents unintentional restarting of motor following an electrical service interruption. Over-current protection prevents damage to motor as a result of overheating.
- “Stop” and “Start” control buttons are 24VDC.
- PE4004 has a 4-way/3-position manual valve.
- PE4004S has a 4-way/3-position solenoid valve with a 24VDC remote hand switch.
- External pressure relief valve is adjustable from 100 to 700 bar.
- Heavy-duty 50,8 mm diameter casters assure easy maneuvering.
- 75,7 l (62,8 l usable) reservoir has a low oil level sight gauge.
- Powered by a dual voltage 7,46 kW, 3 phase, 1437 rpm motor.
- 3 phase motor has all the electrical components necessary to operate the pump. **The customer has no hidden charges when making a purchase.**
- Deliver 16 l/min. of oil @ 15 bar, 5,6 l/min. of oil @ 700 bar.
- CE rated.

### ▶ Performance Specifications

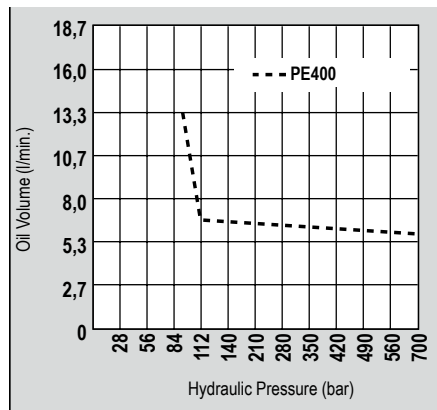



**Analog Gauges**



Improve your system visibility and safety by adding an inline hydraulic gauge to your circuit.

**9040E (63 mm)  
9052E (100 mm)**



**Load Lowering Valve**



Operation: Permits free flow when extending cylinder, built-in pressure relief and Posi-Check® locks and holds load in raised position until operator opens valve.  
Ordering number: **9596**



**Learn More - About Hydraulic Safety Insight**



Looking for great safety suggestions? Visit our Resource Section to get a better understanding of hydraulic and mechanical safety insights on what to look for when working around hydraulics

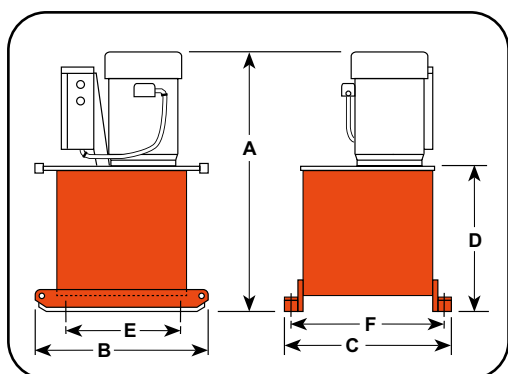

**Technical Dimensions**

Order No.	A	B	C	D	E	F	Max. Pressure Output (bar)	rpm	dBA at Idle and 700 (dBA)	Max. Amp Draw @ 700 bar (A)	Oil Del. (l/min. @)				Prod. Wt. * with Oil (kg)
	(mm)	(mm)	(mm)	(mm)	(mm)	(mm)					15 (bar)	90 (bar)	350 (bar)	700 (bar)	
PE4004-E380	924	635	610	540	394	546	700	1,437	73/80	15,5	16	15	6	5,6	223
PE4004S-E380	924	635	610	540	394	546	700	1,437	73/80	15,5	16	15	6	5,6	229

\* Add 5" and 8 kg when casters are mounted. (Units are supplied with four 4" dia. swivel casters.)

**Ordering Information**

For Use With Cylinder Type	Description	Order No.	Valve Type	Valve No.	Valve Function	Max. Amp Draw @ 700 bar	Motor	Reservoir Usable Oil Cap. † (l)
Double-Acting	7,46 kW pump with 75,5 liter reservoir and manual valve.	PE4004-E380	4-Way	9506	Advance Hold Return	400V -15.5 amps	7,46 kW, 4000 volt 50 Hz, 3 Phase	62,8
Double-Acting	PE4004, except has solenoid operated remote valve.	PE4004S-E380	4-Way	9512*	Advance Hold Return	400V -15.5 amps	7,46 kW, 4000 volt 50 Hz, 3 Phase	62,8

\* Solenoid valve with remote control.

† Usable oil is calculated with oil fill at recommended level at 2.25" below cover plate.

NOTE: Valves for spring return cylinders are available upon request. Consult the factory.

Model Shown:  
**PE-NUT**

Pumps



**Features**

**EXTREMELY DURABLE YET LIGHTWEIGHT AND OPERATE UNDER LOW-LINE VOLTAGE CONDITIONS.**

- 0,46 kW universal electric motor (50/60 Hz cycle), intermittent duty pump.
- Two-stage pump for rapid ram advance.
- Operational under low-line voltage conditions.
- Designed for use with spring-returned remote tools.
- High-pressure safety relief valve.
- Remote hand control with 3,1 m cord.
- Carrying handle.
- Factory filled oil reservoir.
- Pressure matched quick-coupler supplied.
- Piston-type high-pressure pump supercharged by a low-pressure pump.
- Optional operating pressures available (consult Power Team factory for details).
- Optional carrying case.
- Non CE.

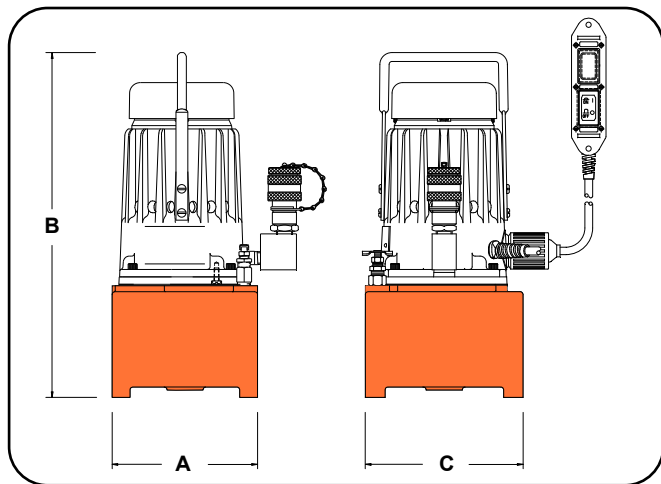

**CAUTION**

**DESIGNED FOR CRIMPING APPLICATIONS ONLY!**  
This system should not be used for lifting.



**Electrical Data**

Electric Motor	Electric Control
0,46 kW, 10,000 rpm 115V, 50 Hz 11 amp current draw (115V @ 700 bar)	Remote control with 3,1 m cord

**Ordering Information**

Order No.	Overall Dimensions			Oil Delivery		Reservoir		Prod. Wt. With Oil (kg)
	A	B	C	7 (bar)	700 (bar)	Oil Cap.	Usable Oil Cap.	
	Width (mm)	Length (mm)	Depth (mm)	(l/min.)	(l/min.)	(l)	(l)	
PE-NUT	165	365	210	2,62	0,49	6	2,8	12,6
PE-NUTC*	165	365	210	2,62	0,49	6	2,8	12,6

\* Includes Case

Model Shown:

**PG1203/4S-CP**



**Features**

**TWO-STAGE PUMP FOR CRIMPING APPLICATIONS**

**PG1203-CP**

- 6 hp Briggs & Stratton engine.
- Manual control valve.
- High-pressure safety relief valve.
- Protective roll cage.
- For use with single acting tools.

**PG1203/4S-CP**

- 5.5 hp Honda OHV-type engine.
- Solenoid valve with remote hand control with 3,1 m cord.
- Two-stage pump for rapid advance.
- High-pressure safety relief valve.
- Protective roll cage.
- For use with either single or double-acting tools.

Pumps



**Hydraulic Hoses**



Heavy-duty and thermo plastic hydraulic hoses to meet your requirements and safety factor.

Refer to accessories section for details



**CAUTION**

**DESIGNED FOR CRIMPING APPLICATIONS ONLY!**  
This system should not be used for lifting.

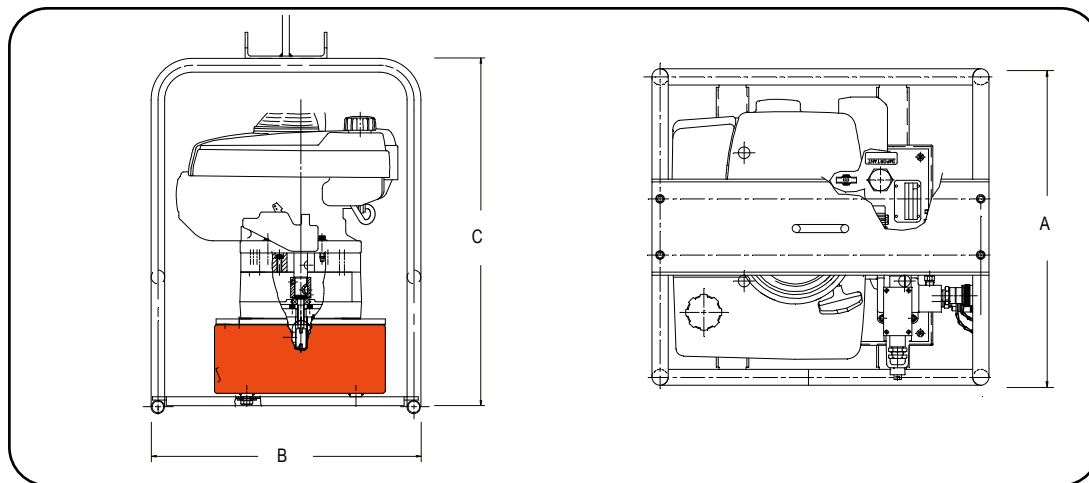

**Ordering Information**

Order No.	Overall Dimensions			Oil Delivery		Reservoir		Prod. Wt. With Oil (kg)
	A	B	C	7 (bar)	700 (bar)	Oil Cap.	Usable Oil Cap.	
	Width (mm)	Length (mm)	Depth (mm)	(l/min.)	(l/min.)	(l)	(l)	
PG1203-CP	502	552	622	8	2,1	11,3	7	25
PG1203/4S-CP	502	552	622	8	2,1	11,3	7	25

Model Shown:

**PG304, PG554**



Pumps

▶ Gasoline Powered Hydraulic Pumps like this PG303 help provide hydraulic force at remote locations.

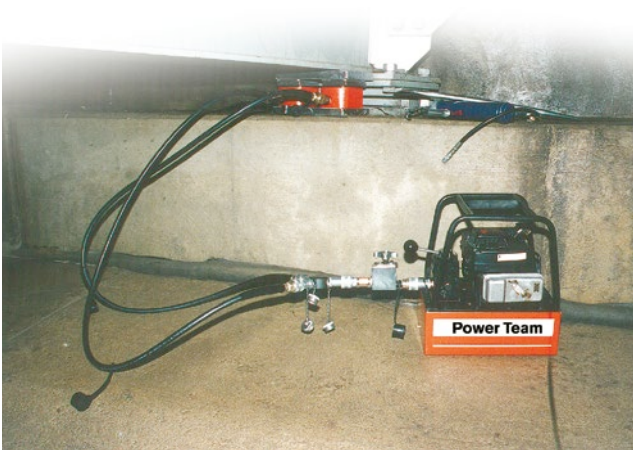

▶ **Features**

**GASOLINE POWER IDEAL FOR REMOTE LOCATIONS.**

- A logical choice at work sites where electricity or compressed air are unavailable. For single or double-acting cylinders at operating pressures up to 700 bar.
- All gasoline engine/hydraulic pumps feature Posi-Check® valve to guard against pressure loss when valve is shifted from “advance” to “hold.”

**PG303 AND PG304 (UP TO 68 TON)**

- Powered by a 4-cycle, 1,5 kW Honda engine giving it the lowest weight to horsepower ratio of all gasoline driven pumps.
- Has an aluminum reservoir with 6 l of usable oil.
- PG30 series pumps are equipped with roll cages to protect pump from damage.
- PG303 is for single-acting cylinders, has a 9520 valve with separate internal return line which allows oil from running pump to return to reservoir, independently of cylinder return oil, when valve is in “return” position.
- PG304 is for double-acting cylinders, has a 9506 4-way (tandem center) valve.

**PG553 AND PG554 (UP TO 136 TON)**

- 4,5 kW Intek “Diamond Edge” 4-cycle, by Briggs & Stratton.
- 19 liter reservoir.
- PG553 has a 9520 3-way valve for single-acting cylinders.
- PG554 has a 9506 4-way valve for double-acting cylinders.
- Optional roll cage available.

▶ **Performance Specifications**

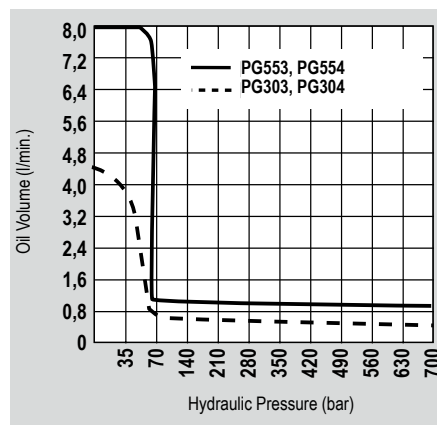



**Hydraulic Hoses**



Heavy-duty and thermo plastic hydraulic hoses to meet your requirements and safety factor.

Refer to accessories section for details

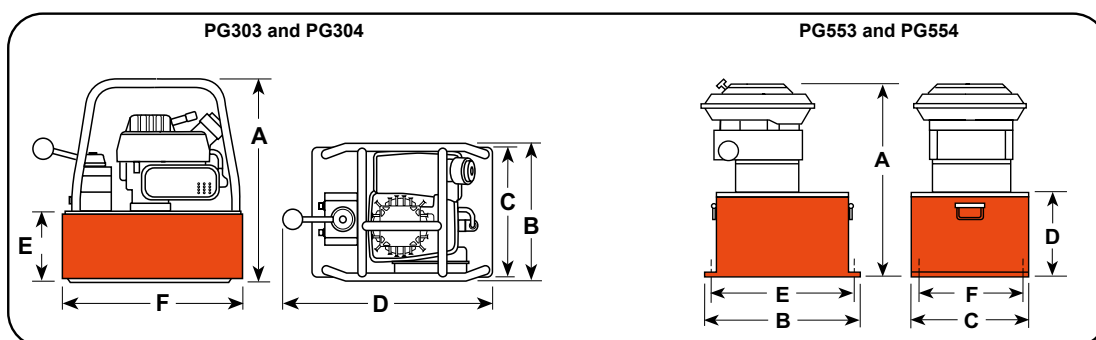

**Technical Dimensions**

Order No.	A	B	C	D	E	F	Max. Pressure Output (bar)	rpm	Oil Del. (l/min. @)				Prod. Wt. with Oil (kg)
	(mm)	(mm)	(mm)	(mm)	(mm)	(mm)			7 (bar)	70 (bar)	350 (bar)	700 (bar)	
PG303, PG304	378	264	241	406	130	343	700	6000	4,4*	0,6	0,6	0,5	14,5
PG553, PG554	559	457	318	219	422	229	700	3600	7,7	1,2	1,1	0,9	54,4

\* First stage oil delivery from 27,6 bar @ 3,7 l/min minimum.

**Ordering Information**

For Use With Cylinder Type	Description	Order No.	Valve Type	Valve No.	Valve Function	Reservoir Usable Oil Cap. (l)	Horsepower	Cycle
Single-Acting	1,5 kW pump with 7,6 liter reservoir and single-acting valve.	PG303	3-Way	9520	Advance Hold Return	6	1,5	2
Single-Acting	4,5 kW pump with 21,6 liter reservoir and single-acting valve.	PG553	3-Way	9520	Advance Hold Return	20,8 **	4,5	4
Double-Acting	PG303, except has double-acting valve	PG304	4-Way	9506	Advance Hold Return	6	1,5	2
Double-Acting	PG553, except has double-acting valve	PG554	4-Way	9506	Advance Hold Return	20,8 **	4,5	4

\*\* Usable oil is calculated with oil fill at recommended level at 13 mm below cover plate.

Model Shown:

**PG4204S, PG1204S, PG1200M-4D**

Pumps



**Features**

**TWO-SPEED HIGH-PERFORMANCE PUMPS IDEAL FOR CONSTRUCTION, STRUCTURE MOVING AND RIGGING APPLICATIONS.**

- A logical choice at work sites where electricity or compressed air are unavailable. For single or double-acting cylinders at operating pressures to 700 bar.
- All gasoline engine/hydraulic pumps feature Posi-Check® valve to guard against pressure loss when valve is shifted from “advance” to “hold.”
- PG1200 Series pumps powered by a Honda 4-cycle, 5.5 hp engine with automatic decompression and electronic ignition. Deliver over 2,1 l of oil per minute at 700 bar.
- A 19 liter reservoir means adequate capacity for multi-cylinder applications. Dual element air cleaner protects engine from dusty environments.
- Heavy-duty “roll cage” provides pick-up points for lifting. Horizontal bars on PG1203, PG1204 and PG1204S protect unit, provide hand holds for carrying.
- Rubber anti-skid insulation on bottom of reservoir resists skidding and dampens vibration. PG1200M-4 and PG1200M-4D include a pump cart with 305 mm wheels.
- Adjustable external pressure regulator.
- CSA rated for intermittent duty.

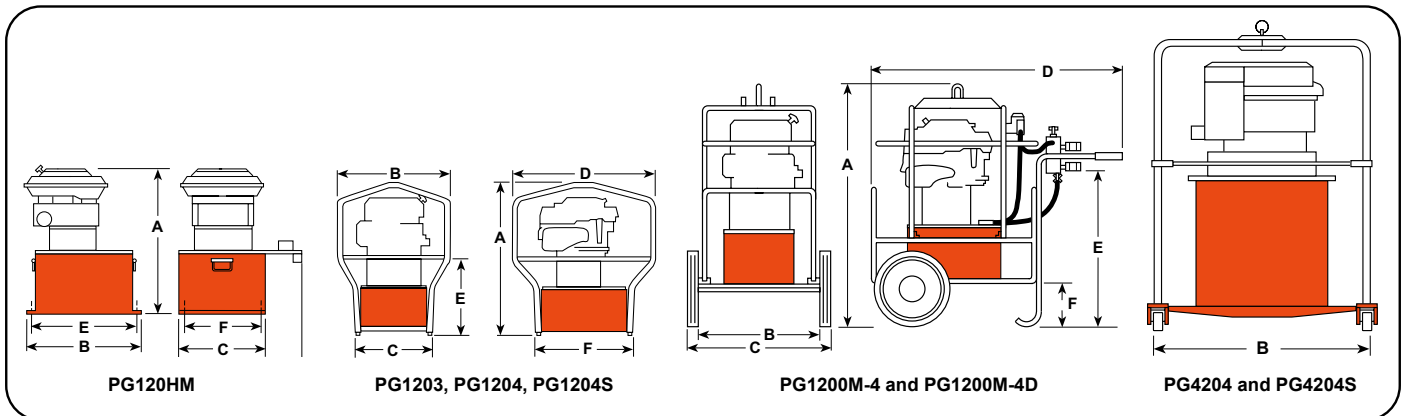

**Technical Dimensions**

Order No.	A	B	C	D	E	F	Max. Pressure Output (bar)	rpm	Oil Del. (l/min. @)				Prod. Wt. with Oil (kg)
	(mm)	(mm)	(mm)	(mm)	(mm)	(mm)			7	70	350	700	
	(bar)	(bar)	(bar)	(bar)									
PG120HM	584	394	362	483	338	308	700	3600	7,7	2,8	2,4	2,1	68
PG1203	708	514	362	667	343	464	700	3600	7,7	2,8	2,4	2,1	70
PG1204	708	514	362	667	343	464	700	3600	7,7	2,8	2,4	2,1	70
PG1204S	708	514	362	667	343	464	700	3600	7,7	2,8	2,4	2,1	73
PG1200M-4	1070	457	635	1080	667	184	700	3600	7,7	2,8	2,4	2,1	118
PG1200M-4D	1070	457	635	1080	667	184	700	3600	7,7	2,8	2,4	2,1	127
PG4204	1276	1321	1321	—	—	—	700	3600	19,8	17,9	7,6	6,4	197
PG4204S	1276	1321	1321	—	—	—	700	3600	19,8	17,9	7,6	6,4	200

**PG1200M-4**

- For single-acting cylinders. Has 9520 3-way/3-position (tandem center) valve, 9596 load-lowering valve and 9644 4-port manifold with individual needle valves at each port.
- Has a 9796 coupler and 9797 dust cap at each port. Valving permits precise individual control of up to four cylinders.
- A 9052 heavy-duty, fluid filled pressure gauge (0-700 bar) is included.

**PG1200M-4D**

- For single or double-acting cylinders with precise individual control of up to four cylinders possible.
- Equipped same as PG1200M-4, except has 9506 4-way/3-position (tandem center) valve, and second 4-port manifold without needle valves mounted beneath 9644 manifold for operating double-acting cylinders.

**PG420 SERIES MAXIMUM OUTPUT HYDRAULIC POWER PACKAGE**

- Ideal for single or multiple cylinder applications. Has a 4-cycle, 15 kW Honda engine and 76 l hydraulic reservoir (63 l usable) with low oil level sight gauge.
- Steel roll cage protects pump, has a lifting hook, and 102 mm dia. swivel casters provide mobility.
- Delivers 6,4 l of oil at maximum operating pressure.
- Has a 9506 4-way valve. On/off switch and speed control are protected by a panel. Sturdy molded case protects battery (not included).
- USA EPA Clean Air Act EVAP Certified Product.

► **Performance Specifications**

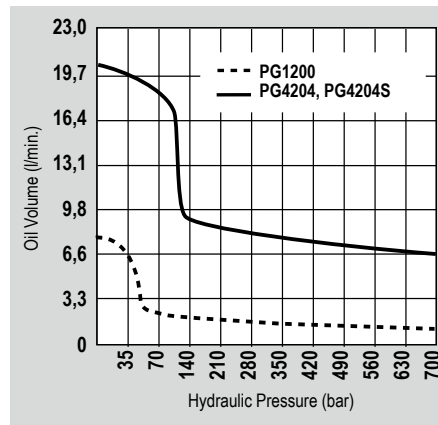

► **Ordering Information**

For Use With Cylinder Type	Description	Order No.	Valve Type	Valve No.	Valve Function	Reservoir *Usable Oil Cap. (l)	Horsepower	Cycle
Single-Acting	Base model 4,1 kW gasoline pump with 22 liter reservoir.	<b>PG1203</b>	3-Way	9520	Advance Hold Return	20,8	4,1	4
Single-Acting	PG1203 with cart, roll cage, load lowering valve, 4 port manifold and gauge.	<b>PG1200M-4</b>	3-Way Manifold	9520 9644	Advance Hold Return**	20,8	4,1	4
Single-Acting/ Double-Acting	PG1200M-4D, except without Roll Cage and cart. Ideal for house moving industry	<b>PG120HM</b>	4-Way Manifold	9506 9642	Advance Hold Return**	20,8	4,1	4
Double-Acting	Base model 4,1 kW gasoline pump, with 22 liter reservoir, roll cage and double-acting valve.	<b>PG1204</b>	4-Way	9506	Advance Hold Return	20,8	4,1	4
Double-Acting	PG1204, except has roll cage, solenoid valve and 7,6 meter cord.	<b>PG1204S</b>	4-Way Solenoid***	9516	Advance Hold Return	20,8	4,1	4
Double-Acting	PG1200M-4, except for double-acting systems.	<b>PG1200M-4D</b>	4-Way Manifold	9506 9642	Advance Hold Return**	20,8	4,1	4
Double-Acting	Base model 15 kW pump with 76 liter reservoir.	<b>PG4204</b>	4-Way	9506	Advance Hold Return	62,8 *	15	4
Double-Acting	PG4204, except has solenoid operated remote valve.	<b>PG4204S</b>	4-Way Solenoid***	9516	Advance Hold Return	62,8 *	15	4

\* Usable oil is calculated with oil fill at recommended level at 57 mm below cover plate.

\*\* Control up to 4 cylinders independently.

\*\*\* Has 7,6 m remote control cord.

Model Shown:  
**eSync**



**Features**



- Handheld pendant controls the auto and manual functions allowing a remote position for better visual operation with included storage holster.
- Pendant controls auto synchronous/manual toggle, advance/retract, and stop operation for safety situations that require a quick override.
- Ergonomic IP55 rated remote pendant with 12 ft / 3.6m cord and large button design.



- 39.4" (1000mm) linear position sensors give feedback to the Microprocessor for load location.
- Position sensors allow synchronous movement accuracy to .040" (1mm).
- Linear position sensors include magnet kit to mount to load or cylinder.

**Features**

- eSync includes 4 standard double acting hydraulic points, linkable to 16 eSync units and 64 points.
- Systems can be completely cordless for reliable remote operation or corded when power is available.
- eSync units are available without a pump or included with Power Team PB43 (cordless) or PE55 (corded) hydraulic 10K PSI (700 bar) pumps.
- Systems that include a pump come with everything you need to get started. Just add cylinders and hydraulic hoses for a complete system ready to lift.
- eSync battery supplies hours of continuous run time based on demand with 1 fully charged 8ah battery.



- Protective and stackable uCage comes standard for the eSync, storage totes, and hydraulic pump.

- Three on-board stackable totes allow protection and storage of position sensors and cables.

- Lock-in-place design with secure strap for hassle-free transportation.



- Li-ion 60VDC, 8.0 Ah battery with 4 level battery life indicator.

- Charger available in 115VAC 60HZ or 230VAC 50HZ.

- Global battery compatible with both charger styles.

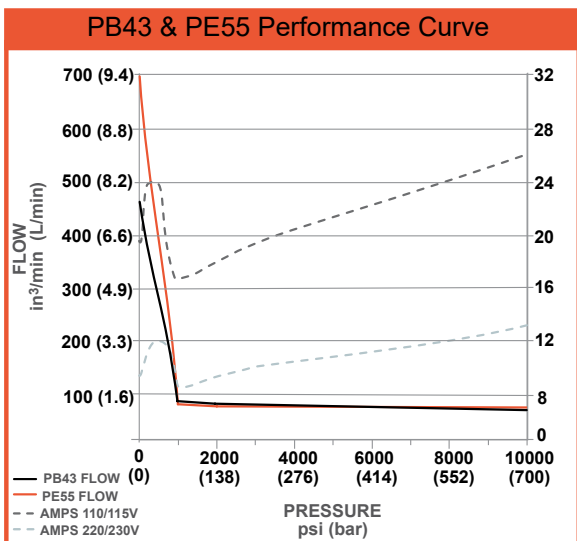

**Powerthon Limited Lifetime WARRANTY**  
ISO 9001 Certified

**Worry-Free Ownership**

Accessories

Accessory Part #	Description
3001434	LINKING CABLE 100' ASSEMBLY - ALLOWS CONNECTION OF MULTIPLE eSync UNITS
2010995	BATTERY CHARGER 115V US PLUG
2011156	BATTERY CHARGER 230V CE EU PLUG
3001464	BATTERY CHARGER 230V CE UK PLUG
3001465	BATTERY CHARGER 230V CE AU PLUG
2010994	BATTERY 60VDC 8ah

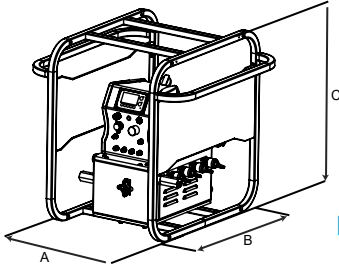

**Fig.1**

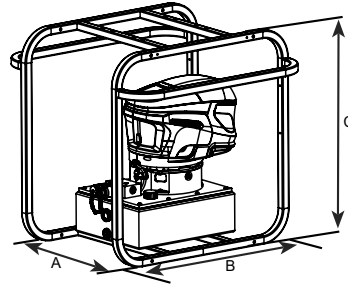

**Fig.2**

Order No.	With uCage in/(mm) (Fig.1)			Pump Included	Voltage	Battery/Charger Included	Sensors/Transducers Included	**Weight lb (kg)
	A	B	C					
ES14PRTXA	19.0 (482.6)	27.0 (685.8)	27.0 (685.8)	N/A	115VAC 60HZ	N/A	(1) System pressure transducer & (4) linear position sensors	130 (59)
ES24PRTXA				N/A	230VAC 50/60HZ	N/A		130 (59)
ES64PRTYXA				N/A	60VDC 8Ah	115VAC 50/60HZ Charger		132 (59,8)
ES64PRTZXA				N/A	60VDC 8Ah	*230VAC (EU) 50/60HZ Charger		132 (59,8)
ES64PRTWXA				N/A	60VDC 8Ah	*230VAC (UK) 50/60HZ Charger		132 (59,8)
ES64PRTXXA				N/A	60VDC 8Ah	*230VAC (AU) 50/60HZ Charger		132 (59,8)
ES14PRTXD				PE551MX2 hydraulic pump	115VAC 60HZ	N/A		261 (118,4)
ES24PRTXD				PE552MX2 hydraulic pump	230VAC 50/60HZ	N/A		261 (118,4)
ES64PRTYXB				PB43MX2-1 hydraulic pump	60VDC 8Ah	115VAC 50/60HZ Charger		269 (122)
ES64PRTZXB				PB43MX2-2 hydraulic pump	60VDC 8Ah	230VAC (EU) 50/60HZ Charger		269 (122)
ES64PRTWXB				PB43MX2-3 hydraulic pump	60VDC 8Ah	230VAC (UK) 50/60HZ Charger		269 (122)
ES64PRTXXB				PB43MX2-4 hydraulic pump	60VDC 8Ah	230VAC (AU) 50/60HZ Charger		269 (122)

\*\*ESYNC WEIGHT: WITH UCAGE

Order No.	With uCage in/(mm) (Fig.2)			Voltage	Pendant	9500 Valve	Batt. Charger Included	RPM	dBA Idle/Max Press.	Oil Delivery - l/min (cu.in/min) @			**Wt lbs (kg)
	A	B	C							7 Bar (100 psi)	350 Bar (5k psi)	700 Bar (10k psi)	
PE551MX2	19.0 (482.6)	27.0 (685,8)	27.0 (685,8)	115VAC 60HZ	No	No	N/A	12k	83/91	11.5 (700)	1.2 (70)	1.0 (60)	131 (59,4)
PE551MA2PE				115VAC 60HZ	Yes	Yes	N/A						
PE552MX2				230VAC 50/60HZ	No	No	N/A						
PE552MA2PE				230VAC 50/60HZ	Yes	Yes	N/A						
PB43MX2-1				60VDC 8Ah	No	No	115VAC 50/60HZ Charger	3.1k	73/75	7.8 (480)	1.2 (70)	0.7 (43)	137 (62,1)
PB43MA2PE-1					Yes	Yes	115VAC 50/60HZ Charger						
PB43MX2-2					No	No	230VAC (EU) 50/60HZ Charger						
PB43MA2PE-2					Yes	Yes	230VAC (EU) 50/60HZ Charger						
PB43MX2-3					No	No	230VAC (UK) 50/60HZ Charger						
PB43MA2PE-3					Yes	Yes	230VAC (UK) 50/60HZ Charger						
PB43MX2-4					No	No	230VAC (AU) 50/60HZ Charger						
PB43MA2PE-4					Yes	Yes	230VAC (AU) 50/60HZ Charger						

\*\*PUMP WEIGHT: FILLED WITH OIL INCLUDING UCAGE

Model Shown:  
**24 Point MCS**



**EASY SETUP AND SUPPORTING OPTIONS**

The MCS is available from 4 to 128-points, with a tilt function that uses the X-Plane with one reference to level an object through an easy-to-use touch screen HMI (human machine interface). Systems can also include a VPN Router using a sim card where, remote troubleshooting and system upgrade is possible. Many options are available for pump sizes with flows up to 6.9 cu. L/min. Weatherproofing options are available with some models including a thermostat temperature-controlled enclosure. There is also a data logging feature within the system settings, plug in your USB drive, and capture the lift data for post review.

**SAFETY FEATURES**

The Power Team Motion Control System (MCS) has numerous safety features built into the digital controller which safely stop the movement in the event of an alarm. In addition, there are backup mechanical features which function even in the event of a power loss.

Digitally Controlled Safety Features		Mechanical Backup Safety Features
Max load exceeded	Hydraulic pump overload	Posi-Check® load lowering valve to hold load and provide a mechanical backup to safely control the lowering of the load.
Max pressure exceeded	E-Stop button activation	
Max displacement exceeded	Pressure sensor wire break	
Datalog	Displacement sensor wire break	Manual lowering override to safely lower load in event of power loss.
System communication error	Accuracy, response velocity and load alerts	

**Features**

- Systems include 4, 8, 12, 16, 24 jacking points, contact Power Team for larger MCS requirements up to 128 points and manifold systems up to 512 points.
- Positioning, lifting or lowering accuracy of +/- 1 mm (.040").
- Safety features included: full stop due to power failure, sensor failure, pressure overload, tolerance error, uncontrolled load movement, etc.
- Intuitive graphic, touch screen control.
- Displayed information included: startup diagnostics, position of lift points relative to starting position, pressure at each lift point, status of each cylinder and status of alarms.
- MCS works with a wide range of cylinder types, tonnages and strokes to meet your application requirements.
- Operating pressure (up to) 700 bar (10,000 psi).
- Easy setup and remote or on-site support

**Training Provided**



Every MCS includes one day of on-site training at one of HT's Regional Headquarters (Rockford, IL USA, Singapore, Melbourne or the Netherlands). Training includes both classroom and hands-on instruction. Travel & lodging not included.



**EASY TO USE HMI TOUCH SCREEN INTERFACE**

Control is as easy as inputting the height you want to move the object and start the cycle by selecting auto, up and hitting go. The MCS does the work while displaying the feedback you need to monitor a safe successful lift like; pressure per cylinder and distance traveled. The system has the capability to warn you of many potential hazards like, over pressure on a cylinder, line breaks, or out of tolerance warnings.

Model Shown:  
**8 Point MCS**

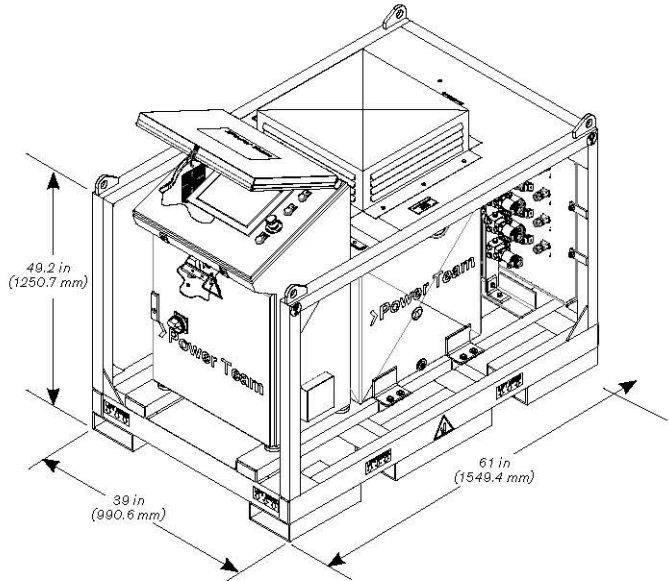

Pumps

**Hardware Included**



Crate

Motion Control System (MCS) is protected with a robust cage and reusable shipping container.



Sensors

Linear Displacement Sensors have a range of 500 mm (19.7") to 1000 mm (39.4"). (Provided in cases with 4 sensors each).



Cables

Standard cables for sensors are 30.5m (100') in length, contact for custom sizes.



Plug

Electrical plug female connector allows for quick attachment to your line cord.

**Ordering Information**

Order No.	Max. Lift Points	Pump Flow	Reservoir Size	Motor Voltage	Control Voltage	Max. Pressure	Valves Included	Transducers Included	Weight w/oil lb (kg)
			L (gal)	hp (VAC)	VDC	bar (psi)			
Contact for order no.	128	1.97 L/min to 6.9 L/min @ 700 bar (120 in <sup>3</sup> /min to 420 in <sup>3</sup> /min @10,000 psi)	150 (40) to 378.5 (100)	1.125 (230) to 10 (230/460)	24	700 (10,000)	3P-4W and 2P-2W	Pressure and Linear Position	Varies per model



**The Power Team Motion Control System (MCS) can be used in many hydraulic applications where load position is critical, requiring cylinder synchronization.**



**CHOOSE YOUR BASIC PUMP, SELECT YOUR ACCESSORIES, AND WE WILL ASSEMBLE, TEST AND SHIP YOUR PUMP.**

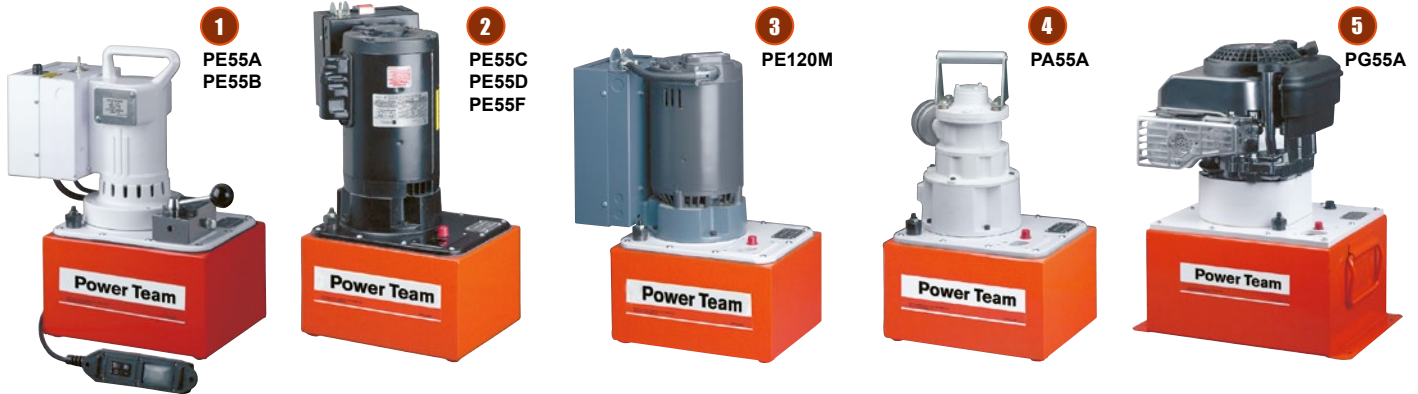

## ORDER A “CUSTOM BUILT” HYDRAULIC PUMP

“Assemble to Order” means you can choose a basic pump with gas, air or electric motor. Then select the proper valve, gauge, pressure control, motor control and reservoir. You get a two-stage pump that gives high oil volume for fast cylinder approach (and return with double-acting cylinders) in the first stage and high pressure in the second stage.

### 1 1-1/8 HP UNIVERSAL MOTOR

These motors start under full load and are suitable for operation up to 5000 or 700 bar. The motor is 0,83 kW, 12000 rpm, 115 or 230V (specify), 50/60 cycle AC single-phase (25 amp draw at 115V). With proper valve they can be used with single or double-acting cylinders.

**NOTE:** Remote control available.

### 2 1-1/2 HP JET MOTOR, SINGLE & THREE-PHASE

Feature low noise level, moderate speed for long service and are ideal for fixed applications. Motor is 1,12 kW, 3450 rpm, 115 or 230V, 50 or 60 cycle (specify), AC single-phase with thermal overload switch. Can be used with single or double-acting cylinders and equipped with remote control. Also available in 230/460V, three-phase (specify).

**NOTE:** These do not start under full load unless valve is in “neutral” (requires open or tandem center valve) and are not recommended for frequent starting and stopping.

### 3 3 HP JET MOTOR, THREE-PHASE

Gives low noise level and long life due to its moderate operating speed. Ideal for fixed installations. Consists of basic 700 bar pump, jet pump motor: 2,2 kW, 3450 rpm, 230/460V, 60 or 50 cycle (specify). AC three-phase, with thermal overload switch. Equipped with internal and external relief valve. Will start under load.

### 4 3 HP AIR MOTOR

This pump is ideal for use where electricity is unavailable or cannot be used. The 5000 or 700 bar pump has a 2,2 kW air-driven motor at 3000 rpm (optimum performance based on 6 bar air pressure and 50 cfm at the pump). You can drive single or double-acting cylinders with the correct valve.

**NOTE:** 6 bar air supply required to start under full load.

### 5 GASOLINE ENGINE

This version is perfect when electricity and air are unavailable. It is capable of continuous operation at full pressure. Consists of basic 700 bar pump, 4-cycle Briggs & Stratton “Diamond Edge” gasoline engine, developing 6 hp. As with all these pumps, this unit can be valved for use with either single or double-acting cylinders.

**► Performance Specifications**

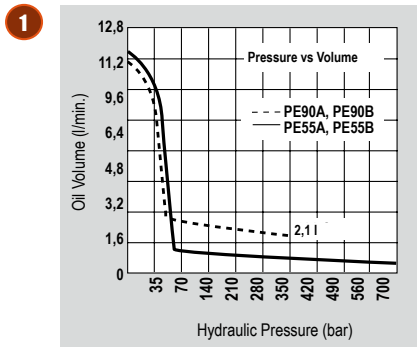

dBA @ Idle and 700 bar - 90/95  
dBA @ Idle and 350 bar - 90/95

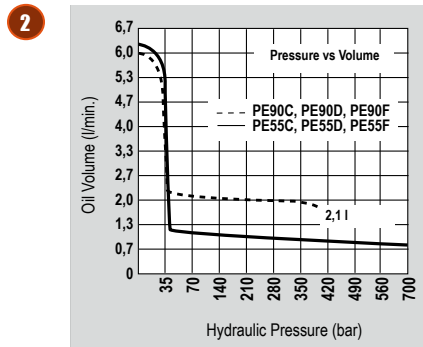

dBA @ Idle and 700 bar - 80/85

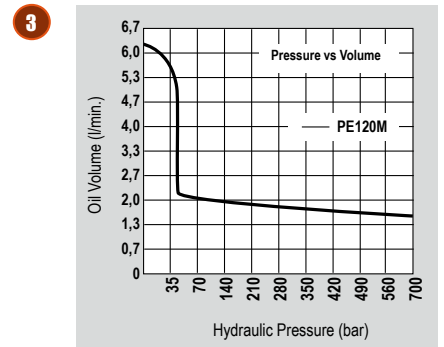

dBA @ Idle and 700 bar - 80/85

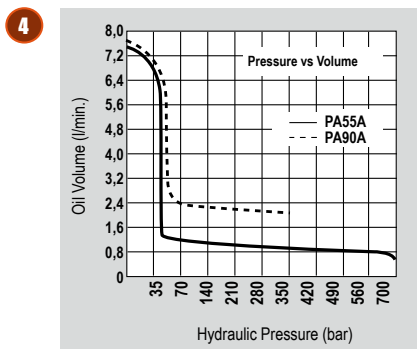

dBA @ Idle and 700 bar - 83/88  
dBA @ Idle and 350 bar - 83/88

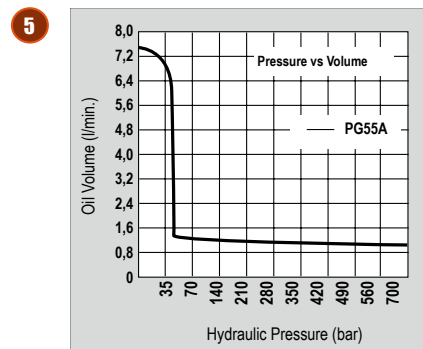

**► “Assemble to order” pump how to order your “custom” hydraulic pump...**

You can choose from pre-engineered, off-the-shelf components to customize your pump. All the components are listed in table form, with key letters or numbers on pages 108-109. Complete instructions guide you so you can determine what is needed to complete a pump assembly. Shown below is an example of a custom-built pump.

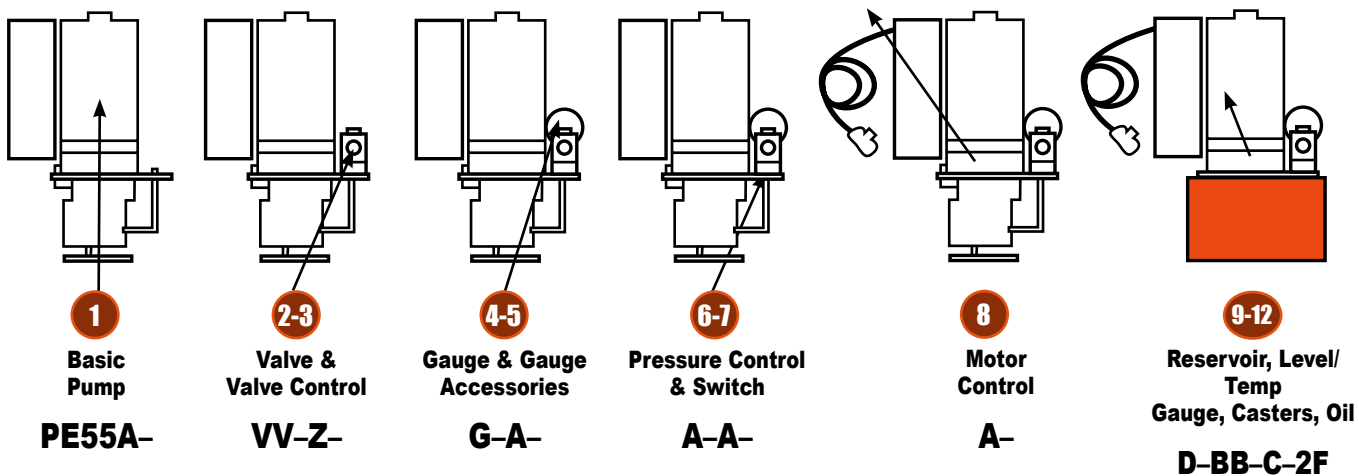

Pump No. **PE55A-VV-Z-G-A-A-A-A-D-BB-C-2F** is a 700 bar two-speed pump with a 115V, 50-60Hz, single-phase, 1,12 kW, 12000 rpm motor; a 9512 4-way solenoid valve with a 202778 remote hand control, a 9041 pressure gauge, no gauge accessories, standard pressure control, standard On/Off/Pulse motor control, 40063OR9 7,6 reservoir, a 350431 oil level/temperature gauge, 10494 casters, and 7,6 l of standard hydraulic oil.

See next two pages for pump components

**TO BUILD YOUR PUMP, FILL IN KEY LETTERS FROM CHARTS**

<b>1</b> Basic Pump	<b>2</b> Select Valve	<b>3</b> Select Valve Control	<b>4</b> Select Gauge	<b>5</b> Select Gauge Accessory	<b>6</b> Pressure Control
<b>7</b> Pressure Switch	<b>8</b> Motor Control	<b>9</b> Reservoir	<b>10</b> Oil Level / Temp. Gauge	<b>11</b> Choose Casters	<b>12</b> Select Oil

Use the charts numbered from 1-12 below to select the pump, valve, gauge and other accessories to suit your needs. For the pump, fill in the basic number plus key letter in block 1 above and the key letter only in the blocks 2-12 above for any of the other items. Refer to the appropriate pages in this catalog for more specific information on the products you need.

**1 BASIC PUMP**

BASIC PUMP NUMBERS					SPECIFICATIONS		
PE55	PE120	PA55	PA90	PG55	NOTE: Customer must specify voltage required.		
(700 bar)	(700 bar)	(700 bar)	(5,000 bar)	(700 bar)	Power Source	rpm	kW
A					115V-60 Hz, 1Ø	12000	0,84
					110V-50 Hz, 1Ø	12000	0,84
B					230V-60 Hz, 1Ø	12000	0,84
					220V-50 Hz, 1Ø	12000	0,84
C **					115V-60 Hz, 1Ø	3450	1,12
C50 **					110V-50 Hz, 1Ø	2850	1,12
D **					230V-60 Hz, 1Ø	3450	1,12
D50 **					220V-50 Hz, 1Ø	2850	1,12
	M60 *				208, 230/460V-60 Hz, 3Ø	3450	2,24
	M50 *				220/380V-50 Hz, 3Ø	2850	2,24
		A	A		Air Motor	3000	2,24
				A	Gas Engine	3600	4,47

\* Voltage Specification Required.

\*\* These pumps do not start under full load unless valve is in "neutral" position (requires open or tandem center valve) and are not recommended for frequent starting and stopping.

**2 VALVE**

Manifold / Manual / Air-Operated Directional Valves	Function
AB 9628 manual, tandem center	4-way, 3-pos. valve
AC 9632 manual "twin" tandem and open center	valve
A None	—
B 9626 manifold	Manifold 3-way, 2-pos. valve
C 9584 manual	
D 9582 manual	
E 9610 automatic, pilot-operated	
G 9504 manual	
JJ 9594 air-operated	3/4-way, 2-pos. valves
L 9502 manual, closed center "non-interflow"	3-way, 3-pos. valve
M 9520 manual, tandem center Posi-Check®	

Manifold / Manual / Air-Operated Directional Valves	Function
O 9609 manual, pressure compensated flow control	3-way, 4-pos.
R 9506 manual, tandem center Posi-Check®	4-way, 3-pos. valves
RR 9511 manual, open center	
S 9500 manual, tandem center	
T 9507 manual, closed center Posi-Check®	
U 9501 manual, closed center	
Solenoid-Operated Directional Valves	
FF 9569 solenoid-operated - 24V	3-way, 2-pos.
HH 9572 solenoid-operated - 24V	3/4-way, 2-pos.
PP 9599 solenoid-operated - 24V	3-way, 3-pos.
VV 9512 solenoid-operated - 24V	4-way, 3-pos. valves
WW 9615 solenoid-operated - 24V	

**3 VALVE CONTROL**

Valve Remote Control	Use with Valve
A None	—
X 304718 remote hand control, 3,1 m	9572
XF 309652 remote foot control, 3,1 m	9572
Y 202777 remote hand control, 3,1 m	9569 or 9599

Valve Remote Control	Use with Valve
Z 202778 remote hand control, 3,1 m	9512 or 9615
ZF 309653 remote foot control, 3,1 m	9512, 9615, 9569 or 9599
ZZ 209593 remote hand control, 3,7 m	9594

Pumps

**4 GAUGE**

Pressure Gauge	
A	None
B	Other – Specify
G	9041 0-700 bar – 0-689 Bar (63 mm diameter)
H	9040 0-700 bar – 0-689 Bar (Liquid) (63 mm diameter)
J	9051 0-700 bar – 0-689 Bar (100 mm diameter)
M	9052 0-700 bar – 0-689 Bar (Liquid) (100 mm diameter)

**5 GAUGE ACCESSORY**

Gauge Accessories	
A	None
N	9049 pulsation dampener – All dry gauges

**6 PRESSURE CONTROL**

Pressure Controls	
A	With standard external pressure regulator
C	Other – specify
D	350199 premium external pressure regulator. See Power Team Catalog product No. 9633 for details.

**NOTE:** Pressure controls are factory pre-set at 700 bar unless otherwise specified.

**7 PRESSURE SWITCH**

Pressure Switch	
A	None
B	9625 electric pressure switch (500-700 bar) <b>NOTE:</b> Pressure switch is factory pre-set at 700 bar unless otherwise specified.
C	9641 pilot-operated air control valve – Normally closed
D	9643 pilot-operated air control valve – Normally opened

**8 MOTOR CONTROL**

Electric Motor Controls	
A	Standard On/Off/Pulse control (does not include remote switch) for A, B, C, D, F and M electric pumps. Also used for remote controlled solenoid valves.
B	None
C	25017 remote motor hand switch, 3,1 m
D	203225 remote motor hand switch, 3,1 m (heavy-duty)
E	10461 remote motor foot switch, 3,1 m
Air Motor Controls	
AA	Other – specify
B	None
P	27876 hand motor control (for PA55 & PA90 series)
Q	27877 foot motor control (for PA55 & PA90 series)

**9 RESERVOIR**

Reservoir		Capacity
A	None	–
B	Other – Specify	–
D	40063OR9 – PE55, PE120, PA55 and PA90 series	9,5 l
E	61165† – PE55, PE120, PA55 and PA90 series  (Oil temperatures in excess of 65,5° C. may cause permanent failure of the thermoplastic reservoir)	7,6 l
F	RP22‡ – PE55, PE120, PA55 and PA90 series	9,5 l
H	61799OR9. Same as D except with drain port	9,5 l
J	RP50 – PE55, PE120, PA55 and PA90 series	19 l
K	40137OR9 – PG55 series	19 l
P	209124 – PE55, PE120, PA55 and PA90 series	26,5 l
V	RP100 – PE55, PE120, PA55 and PA90 series	37,9 l
W	RP101 – PG55 series	37,9 l

**NOTE:** Includes cover adapter and misc. accessories when applicable.

† High density polyethylene.

‡ Aluminum.

**10 OIL LEVEL / TEMP. GAUGE**

Oil Level / Temperature Gauge	
A	None
BB	350431 oil level/temperature gauge

**11 CASTERS**

Casters	
A	None
BB	10494 caster for use with 40063OR9 reservoir (Specify quantity of four)

**12 OIL**

Hydraulic Oil		Capacity
E	Ship pump without oil	–
F	9637 Standard hydraulic oil	3,8 l
G	9638 Standard hydraulic oil	9,5 l
Q	9639 Flame-Out® hydraulic oil	3,8 l
R	9640 Flame-Out® hydraulic oil	9,5 l
U	9645 Biodegradable hydraulic oil	3,8 l
V	9646 Biodegradable hydraulic oil	9,5 l

**NOTE:** Select type of hydraulic oil and specify quantity.

# HYDRAULIC ACCESSORIES

## SELECT FROM A WIDE RANGE OF HYDRAULIC ACCESSORIES TO COMPLETE YOUR SYSTEM REQUIREMENTS

- Power Team offers the widest selection of pump-mounted, remote or in-line valves to control your hydraulic circuit requirements.
- A wide variety of hose types, sizes and configured arrangements in rubber or polyurethane
- High pressure fittings, gauges, and other miscellaneous accessories to fit your needs



Powerthon  
Limited  
**Lifetime**  
WARRANTY  
ISO 9001 Certified

Worry-Free  
Ownership

	<b>Section</b>	<b>Page Content</b>	<b>Pages</b>
	<b>Introduction</b>	Choosing the Right Valve and Circuit Schematics	<b>113-114</b>
	<b>Valves</b>	Valve Selection / Pump Options Pump-Mounted Hydraulic Pump Accessories Remote-Mounted In-Line	<b>115-116 117-124 125-126 127-128 129-131</b>
	<b>Fluids</b>	Standard Hydraulic Oil, Flame Out®, Bio Degradable, Low Temperature	<b>132</b>
	<b>Pump Accessories</b>	Motor Controls, Sub-plates, Air Filter / Regulator / Lubricator, Pressure Switch, Air Control Valves, Oil Cooler Kits, Reservoir Breather Kits, Casters, Fluid Level / Temp. Gauge, Foot Control Guard, Magnetic Strip, Seal Kits, Carts / Roll Cages, Reservoirs	<b>133-134</b>
	<b>Hoses</b>	Rubber, Wire-Braid Polyurethane Non-Conductive	<b>135-137</b>
	<b>Couplers</b>	Quick-Connect, Flush Face	<b>138</b>
	<b>Gauges</b>	Heavy-Duty Hydraulic Digital and Analog	<b>139-142</b>
	<b>Manifolds</b>	Standard Blocks Blocks with Valves	<b>143</b>
	<b>Fittings</b>	Connectors, Couplings, Crosses, Elbows, Tees, Swivels, Special Adapters	<b>144</b>



## SELECTING THE RIGHT VALVE:

**Step 1:** What is the tool requirement for valve control - single or double-acting?

**Step 2:** Determine how you intend to plumb the valve in hydraulic circuit - mounted or remote?

**Step 3:** How will you operate it - manual or remote? What type of directional control is needed?



## VALVE SIZING CONSIDERATIONS:

- Will the valve be used with single or double-acting cylinders?
- Will the valve be mounted on the pump, away from the pump or directly into the hydraulic lines?
- Will the valve be manually-operated or is remote control preferred?
- Is independent control of multiple cylinders, or hydraulic tools preferred?
- What directional control and pressure control valve functions are needed for the application?
- Note: Basic valve types include manually-operated, air or solenoid-operated and pilot-operated. Special application valves for pre-stressing and post-tensioning are also offered. Consult valve selection chart on pages 115-116 for listings of all Power Team valves.

## DIRECTIONAL CONTROL VALVES

### 2-WAY, 2-POSITION

(FOR CONTROL OF SINGLE-ACTING CYLINDERS)

POSITION 1	CENTER POSITION	POSITION 2
 <p>Oil goes from pump to cylinder. Pressure is held from valve to cylinder when pump is shut-off.</p>	None	 <p>Oil goes from cylinder to pump. Pressure is released to reservoir when motor is turned off.</p>



### 3-WAY, 2-POSITION

(FOR CONTROL OF SINGLE-ACTING CYLINDERS)

POSITION 1	CENTER POSITION	POSITION 2
 <p>Oil goes from pump to cylinder and holds when pump is shut-off. Return line to reservoir is blocked.</p>	None	 <p>Cylinder retracts, oil returns to reservoir.</p>

### 3-WAY, 3-POSITION

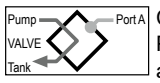
(FOR CONTROL OF SINGLE-ACTING CYLINDERS)

POSITION 1	CENTER POSITION	POSITION 2
 <p>Oil goes from pump to cylinder and holds when pump is shut-off. Return line to reservoir is blocked.</p>	 <p>Cylinder pressure is held. Pump can remain running and oil returns to reservoir.</p>	 <p>All oil is open to reservoir through return line.</p>



**IN-LINE HYDRAULIC VALVES**

- Load-Lowering Valve** – Provides precision metering for controlled return of the cylinder piston.
- Sequence Valve** – Used when a cylinder in a multiple cylinder application must advance before any other.
- Pressure Reducing Valve** – Permits independent pressure control to two or more, clamping systems operated by a single power source.
- Shut-off Valve** – For fine metering of hydraulic oil. Several may be used to control multiple single-acting cylinders.
- Check Valve** – Permits flow of hydraulic oil in one direction only.

- Pressure Relief Valve** – Used at remote locations in a hydraulic circuit where maximum pressure requirements are less than the setting of the basic overload valve in the pump. Protects a hydraulic system against over pressurization.
- Metering Valve** – Restricts surges by restricting flow to a certain level. When flow subsides, valve reopens automatically. For systems using large cylinders or extended lengths of hose.
- Pressure Regulator Valve** – Permits external adjustment of operating pressures at various values below the internal relief valve setting of the pump.

**CAUTION:** To prevent sudden, uncontrolled descent of a load as it is being lowered, use a 9596 Load-Lowering Valve or 9720 Counter Balance Valve in conjunction with the directional valve used in your application.

**DIRECTIONAL CONTROL VALVES**

**4-WAY, 2-POSITION  
(FOR CONTROL OF SINGLE-ACTING CYLINDERS)**

POSITION 1	CENTER POSITION	POSITION 2
<p>Oil goes to the "extend" side of the cylinder. The oil from the "retract" side returns to reservoir. Cylinder holds with pump shut-off.</p>	<p>None</p>	<p>Oil goes to the "retract" side of the cylinder, oil from the "extend" side returns to reservoir.</p>

**4-WAY, 3-POSITION  
(FOR CONTROL OF DOUBLE-ACTING CYLINDERS)**

POSITION 1	CENTER POSITION	POSITION 2
<p>Oil goes to the "extend" side of the cylinder, oil from the "retract" side returns to reservoir. Cylinder holds with pump shut-off.</p>	<p>Holds pressure even if pump is running. Oil from pump goes through valve, back to reservoir.</p>	<p>Oil goes to "retract" side of cylinder. Oil from "extend" side returns to the reservoir.</p>

**TYPICAL CENTERS**

TANDEM CENTER	CLOSED POSITION	OPEN CENTER
<p>Cylinder ports are blocked, oil from pump goes to reservoir. Used when pump remains running. Example: gasoline-driven pumps.</p>	<p>Generally used when running multiple valves in series from one pump.</p>	<p>Open Center used when holding is not a requirement, as when running two separate hydraulic tools such as cutters / crimpers.</p>

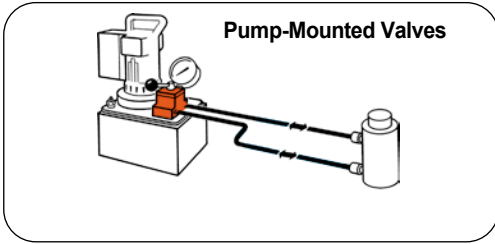

Order No.	Page No.	Cylinder* Applications	Operation	Valve Type	Volt	Advance / Return	Advance / Hold Return	**Posi-Check® Feature
9500	120	SA / DA	Manual	4-Way, 3-Pos. Tandem Center	—	No	Yes	No
9501	120	SA / DA	Manual	4-Way, 3-Pos. Closed Center	—	No	Yes	Yes
9502	119	SA	Manual	3-Way, 3-Pos. Closed Center	—	No	Yes	Yes
9504	118	SA / DA	Manual	3/4-Way, 2-Pos.	—	Yes	Yes	No
9506	120	DA	Manual	4-Way, 3-Pos. Tandem Center	—	No	Yes	Yes
9507	120	DA	Manual	4-Way, 3-Pos. Closed Center	—	No	Yes	Yes
9511	120	SA / DA	Manual	4-Way, 3-Pos. Open Center	—	Yes	Yes	No
9512	123	DA	Solenoid	4-Way, 3-Pos. Tandem Center	24	No	Yes	Yes
9513	123	DA	Solenoid	4-Way, 3-Pos. Tandem Center	115	No	Yes	Yes
9516	123	DA	Solenoid	4-Way, 3-Pos. Tandem Center	12	No	Yes	Yes
9517	118	SA	Manual	2-Way, 2-Pos.	—	No	Yes	No
9519	123	DA	Solenoid	4-Way, 3-Pos. Tandem Center	230	No	Yes	Yes
9520	119	SA	Manual	4-Way, 3-Pos. Tandem Center	—	No	Yes	Yes
9522	123	DA	Solenoid	4-Way, 3-Pos. Open Center	230	Yes	No	No
9523	123	SA	Pilot-Operated Solenoid	3-Way, 2-Pos.	230	Yes	No	No
9552	122	SA / DA	Solenoid	3/4-Way, 2-Pos.	230	Yes	No	No
9553	123	SA	Pilot-Operated Solenoid	3-Way, 2-Pos.	24	Yes	No	No
9569	122	SA	Solenoid	3-Way, 2-Pos.	24	No	Yes	No
9570	122	S.A.	Solenoid	3-Way, 2-Pos.	230	No	Yes	No
9572	122	SA / DA	Solenoid	3/4-Way, 2-Pos.	24	Yes	No	No
9579	122	SA	Solenoid	3-Way, 2-Pos.	115	No	Yes	No
9582	117	SA	Manual	3-Way, 2-Pos.	—	No	Yes	No
9584	117	SA	Manual	3-Way, 2-Pos.	—	No	Yes	No
9589	123	SA	Pilot-Operated Solenoid	3-Way, 2-Pos.	115	Yes	No	No
9590	123	DA	Solenoid	4-Way, 3-Pos. Open Center	115	Yes	No	No
9592	122	SA / DA	Solenoid	3/4-Way, 2-Pos.	115	Yes	No	No
9594	122	SA / DA	Air	3/4-Way, 2-Pos.	—	No	Yes	Yes
9599	121	SA	Pilot-Operated Solenoid	3-Way, 3-Pos. Tandem Center	24	No	Yes	Yes
9605	121	SA	Pilot-Operated Solenoid	3-Way, 3-Pos. Tandem Center	115	No	Yes	Yes
9609	121	SA	Manual	3-Way, 3-Pos. Tandem Center	—	No	Yes	No
9610	117	SA	Auto Pilot-Operated	3-Way, 2-Pos.	—	Yes	No	No
9610A	117	SA	Manual	2/3-Way, 2-Pos.	—	No	Yes	No
9615	123	DA	Solenoid	4-Way, 3 Pos. Open Center	24	Yes	No	No
9628	124	SA / DA	Manual	Post-Tensioning	—	Special	No	No
9632	124	SA / DA	Manual	Post-Tensioning	—	Special	No	No

**Note:**

\* "SA" represents single-acting cylinders and "DA" represents double-acting cylinders.

\*\* The Posi-Check® feature guards against pressure loss when shifting from "advance" to "hold" position.

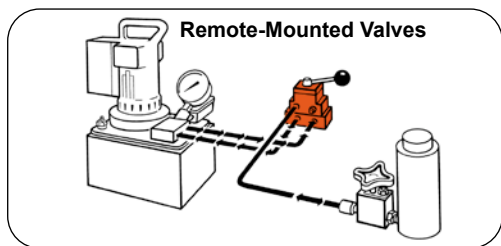

Order No.	Page No.	Cylinder Applications*	Operation	Valve Type	Volt	Advance / Return	Advance / Hold Return	**Posi-Check® Feature
9508	128	SA / DA	Manual	4-Way, 3-Pos. Closed Center	—	No	Yes	Yes
9509	128	SA / DA	Manual	4-Way, 3-Pos. Tandem Center	—	No	Yes	Yes
9514	128	DA	Solenoid	4-Way, 3-Pos. Tandem Center	115	No	Yes	Yes
9524	127	SA / DA	Solenoid	3/4-Way, 2-Pos.	230	No	Yes	No
9525	128	DA	Solenoid	4-Way, 3-Pos. Tandem Center	230	No	Yes	Yes
9526	128	SA	Solenoid	3-Way, 2-Pos.	230	No	Yes	No
9554	127	SA / DA	Solenoid	3/4-Way, 2-Pos.	24	No	Yes	No
9555	128	DA	Solenoid	4-Way, 3-Pos. Tandem Center	24	No	Yes	Yes
9556	128	SA	Solenoid	3-Way, 2-Pos.	24	No	Yes	No
9559	128	SA	Solenoid	3-Way, 2-Pos.	115	No	Yes	No
9593	127	SA / DA	Solenoid	3/4-Way, 2-Pos.	115	No	Yes	No
9595	127	SA / DA	Air	3/4-Way, 2-Pos.	—	No	Yes	No

**Note:**

\*SA represents single-acting cylinders and "DA" represents double-acting cylinders.

\*\* The Posi-Check® feature guards against pressure loss when shifting from "advance" to "hold" position.

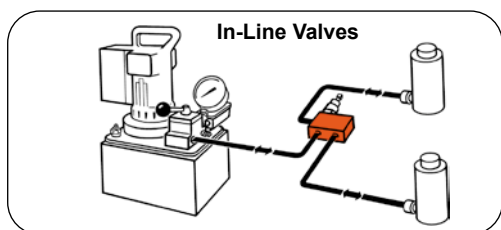

Order No.	Page No.	Cylinder Applications*	Operation	Valve Type
9575	131	SA	Manual	Shut-Off Valve
9580	131	SA	Automatic	One-Way Check Valve
9581	131	SA / DA	Automatic	Pilot-Operated Check Valve
9596	129	SA	Manual	Load-Lowering Valve
9597	129	SA / DA	Automatic	Sequence Valve
9608	129	SA / DA	Automatic	Pressure Reducing Valve
9623	131	SA / DA	Automatic	Pressure Relief Valve
9631	130	SA / DA	Automatic	Metering Valve
9633	130	SA / DA	Automatic	Pressure Regulator Valve
9720	129	SA / DA	Automatic	Counter Balance Valve
9721	129	SA / DA	Automatic	Counter Balance Valve
RV21278	130	—	Automatic	Relief Valve

**Note:**

\*SA represents single-acting cylinders and "DA" represents double-acting cylinders.

**3-WAY / 2-POSITION MANUAL VALVES**

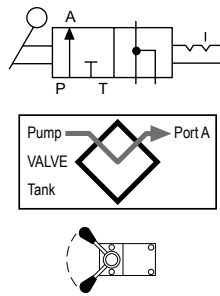
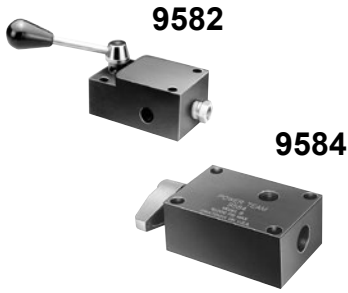

**Applications:** Single-acting cylinders.

**Actuation:** Lever-operated.

**Functions:** Cylinder piston “advance,” “hold” and “return.”

**Used on these pumps:** P460, PE17, PE21, PE30, PE46, PE55, and PE120 series.

Order No.	Description
9582	3-Way/2-Position manual valve. Wt., 1,1 kg.
9584	3-Way/2-Position manual valve “flipper” control. Wt.,0,8 kg.

**3-WAY / 2-POSITION PILOT-OPERATED AUTOMATIC VALVES**

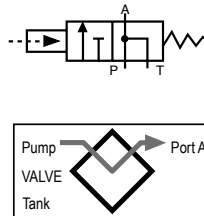

**Applications:** Single-acting cylinders.

**Actuation:** Pilot oil.

**Functions:** When pump is started, pilot oil automatically closes valve and directs oil to cylinder. When pump is stopped, valve automatically opens and oil returns to reservoir.

**Used on these pumps:** Furnished with pilot lines and adapters for PA55, PA90, PE30, PE55, and PE120 series.

Order No.	Description
9610	3-way/2-position pilot-operated automatic valve. Wt., 1,9 kg.

**2/3-WAY/2-POSITION MANUAL/PILOT-OPERATED AUTOMATIC VALVE**

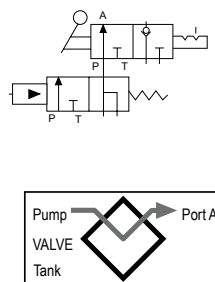

**Applications:** Manual operation for load lifting and holding with single-acting cylinders; automatic “dump” for operating hydraulic tools.

**Actuation:** Flipper lever/pilot oil.

**Functions:** With lever in closed position, valve will hold the load. When lever is “open,” valve functions as a true automatic “dump” valve..

**Used on these pumps:** Furnished with pilot lines and adapters for PA55, PA90, PE30, PE55, and PE120 series. For application on other pumps, consult factory.

Order No.	Description
9610A	2/3-way/2-position manual/pilot-operated automatic valve. Wt., 2 kg.

**CAUTION:** To prevent sudden, uncontrolled descent of a load as it is being lowered, use a 9596 Load-Lowering Valve or 9720 Counter Balance Valve in conjunction with the directional valve used in your application.

**IMPORTANT:** Conversion kit 251528 must be used when mounting any of the valves on this page on PA17 or PE17 pumps.

**IMPORTANT:** When ordering any valve for a PE30 or PG30 series pump, 12,7 mm longer mounting screws are required. For valves 9504, 9584, 9610 and 9610A, order four 12001 cap screws. For valve 9582, order two 12001 and two 10856 cap screws.

**2-WAY/2-POSITION MANUAL VALVE**

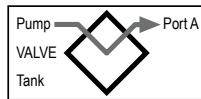
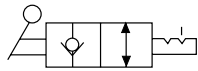

**Applications:** Single-acting cylinders.  
**Actuation:** Flipper lever-operated.  
**Functions:** Cylinder piston "advance," "hold" and "retract."  
**Used on these pumps:** PE172 and PA172.

Order No.	Description
9517	2-way/2-position manual valve. Wt., 1,5 kg.

**3/4-WAY/2-POSITION MANUAL VALVE**

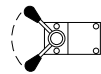
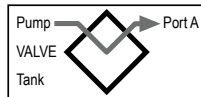
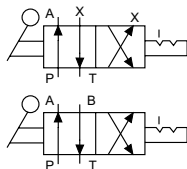

**Applications:** Single or double-acting cylinders.  
**Actuation:** Lever-operated, detent-positioned.  
**Functions:** Pos. 1 – Oil is directed to "advance" side of cylinder, oil from "retract" side goes to reservoir, cylinder "holds" with pump shut-off. Pos. 2 – Oil goes to "retract" side of cylinder, cylinder "holds" with pump shut-off. When using as a 3-way valve for single-acting cylinders, port "A" or "B" is plugged. See note below regarding plugging of ports and resulting heat build-up..  
**Used on these pumps:** P460, PA6D, PA17, PA46, PA55, PA60, PE17, PE21, PE30, PE46, PE55, PE120, PE400, PQ60 and PQ120 series.

Order No.	Description
9504	3/4-way/2-position manual valve. Wt., 1,9 kg.

**NOTE:** 9504 can be remote-mounted with a 9510 sub-plate.

**CAUTION:** To prevent sudden, uncontrolled descent of a load as it is being lowered, use a 9596 Load-Lowering Valve or 9720 Counter Balance Valve in conjunction with the directional valve used in your application.

**IMPORTANT:** Conversion kit 251528 must be used when mounting any of the valves on this page on PA17 or PE17 pumps.

**IMPORTANT:** When ordering any valve for a PE30 or PG30 series pump, 12,7 mm longer mounting screws are required. For valves 9504, 9584, 9610 and 9610A, order four 12001 cap screws. For valve 9582, order two 12001 and two 10856 cap screws.

**NOTE:** Valves 9501, 9502, 9504 and 9507 can have a port blocked or have a closed center position. When a port is blocked and the valve is shifted to the blocked port, the pump will generate excessive heat. An electric or rotary air pump can either be turned off manually or with a pressure switch. Reciprocating air pumps may be adjusted to stall out and stop.

**3-WAY/3-POSITION (CLOSED CENTER) NON-INTER FLOW MANUAL VALVE WITH POSI-CHECK<sup>®</sup>**

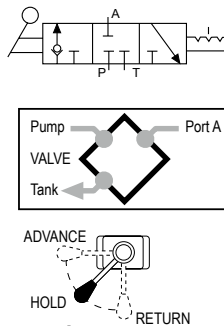

**Applications:** Single-acting cylinders.

**Actuation:** Lever-operated, detent-positioned.

**Functions:** Pos. 1 – Oil is directed from pump to cylinder and “holds” with pump shut-off, line to reservoir is blocked. Pos. 2 – All oil is open to reservoir through tank line. Center Pos. – Cylinder pressure is held, and pump should be shut-off.

**Used on these pumps:** P460, PA17, PA46, PA55, PA60, PE17, PE21, PE30, PE46, PE55, PE120, PE400, PQ60 and PQ120 series.

Order No.	Description
9502	3-way/3-position (closed center) manual valve. Wt., 1,9 kg.

**NOTE:** A pressure switch and/or gauge may be attached if desired. Also, the 9502 can be remote-mounted if a 9510 sub-plate is used.

Accessories

**3-WAY/3-POSITION (TANDEM CENTER) MANUAL VALVE WITH POSI-CHECK<sup>®</sup> VALVE**

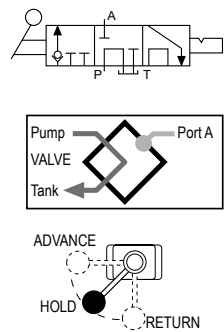

**Applications:** Single-acting cylinders.

**Actuation:** Lever-operated, detent-positioned.

**Functions:** “Advance,” “hold” and “return.” When shifted to “return” position, pump and cylinder return oil through their own separate return lines, allowing faster retraction of piston. The Posi-Check<sup>®</sup> feature guards against pressure loss when shifting from “advance” to “hold” position.

**Used on these pumps:** P460, PA17, PA46, PA55, PE17, PE21, PE30, PE46, PE55, PE120, PQ60, PQ120, PE400, PG30, PG55, PG120 and PG400 series.

Order No.	Description
9520	3-way/3-position (tandem center) manual valve. Wt., 2,3 kg.

**CAUTION:** To prevent sudden, uncontrolled descent of a load as it is being lowered, use a 9596 Load-Lowering Valve or 9720 Counter Balance Valve in conjunction with the directional valve used in your application.

**NOTE:** Valves 9501, 9502, 9504 and 9507 can have a port blocked or have a closed center position. When a port is blocked and the valve is shifted to the blocked port, the pump will generate excessive heat. An electric or rotary air pump can either be turned off manually or with a pressure switch. Reciprocating air pumps may be adjusted to stall out and stop.

**NOTE:** Gauge ports monitor pump pressure only, not pressure to the hydraulic cylinder(s).

**IMPORTANT:** Conversion kit 251528 must be used when mounting any of the valves on this page on PA17 or PE17 pumps.

**IMPORTANT:** When ordering any valve for a PE30 or PG30 series pump, 12,7 mm longer mounting screws are required. For valves 9502 and 9520, order four 12001 cap screws. For valve 9576, order four 17428 cap screws.

**4-WAY/3-POSITION (TANDEM CENTER) VALVE WITH POSI-CHECK®**

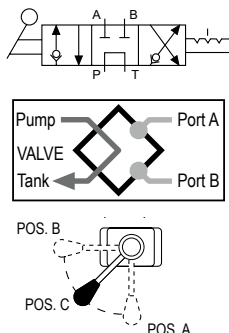

**Applications:** Single or double-acting cylinders.

**Actuation:** Lever-operated, detent-positioned.

**Functions:** "Advance," "hold" and "return." The Posi-Check® feature guards against pressure loss when shifting from "advance" to "hold" position.

**Used on these pumps:** P460, PA6D, PA17, PA46, PA55, PE17, PE21, PE30, PE46, PE55, PE84, PE120, PE400, PED, PG30, PG55, PG120, PG400, PQ60 and PQ120 series.

Order No.	Description
9506	4-way/3-position (tandem center) manual valve. Wt., 2,3 kg.

**4-WAY/3-POSITION (TANDEM CENTER) AND (OPEN-CENTER) MANUAL VALVES**

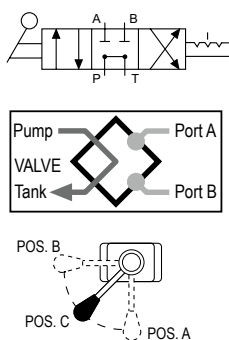

**Applications:** Single or double-acting cylinders.

**Actuation:** Lever-operated, detent-positioned.

**Functions:** The 9500 provides "advance," "hold" and "return." The 9511 (open center) valve can be used if holding is not a requirement, as when running two separate hydraulic tools. Provides "advance" and "return" only.

**Used on these pumps:** P460, PA17, PA46, PA55, PE17\*, PE21, PE30, PE46, PE55, PE120, PE400, PG30, PG55, PG120, PG400, PQ60 and PQ120 series.

\*Does not mount without 251528.

Order No.	Description
9500	4-way/3-position (tandem center) manual valve. Wt., 1,9 kg.
9511	4-way/3-position (open center) manual valve. Wt., 1,9 kg.

**4-WAY/3-POSITION (CLOSED CENTER) MANUAL VALVE WITH POSI-CHECK®**

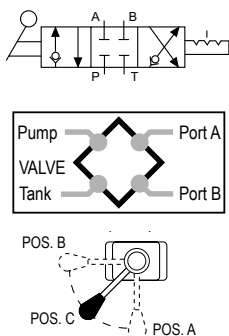

**Applications:** Single or double-acting cylinders.

**Actuation:** Lever-operated, detent-positioned.

**Functions:** Similar to 9506, but is a closed center valve with Posi-Check®. Generally used to operate multiple cylinders with a single pump. Provides "advance," "hold" and "return." The Posi-Check® feature guards against pressure loss when shifting from the "advance" to "hold" position. See note below regarding plugging of ports and resulting heat build-up.

**Used on these pumps:** P460, PA17, PA46, PA55, PA60, PA6D, PE17, PE21, PE30, PE46, PE55, PE120, PE400, PQ60 and PQ120 series.

Order No.	Description
9507	4-way/3-position (closed center) manual valve. Wt., 2,3 kg.

**4-WAY/3-POSITION (CLOSED CENTER) MANUAL VALVE**

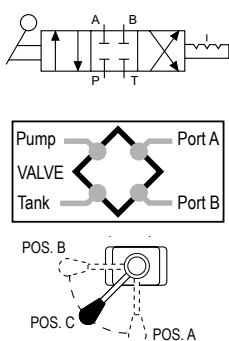
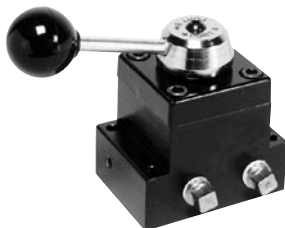

**Applications:** Single or double-acting cylinders.

**Actuation:** Lever-operated, detent-positioned.

**Functions:** "Advance," "hold" and "return." Closed center design makes valve suitable for operating multiple cylinders from a single pump. See note below regarding plugging of ports and resulting heat build-up.

**Used on these pumps:** P460, PA17, PA46, PA55, PA60, PE17, PE21, PE30, PE46, PE55, PE120, PE400, PQ60 and P120 series.

Order No.	Description
9501	4-way/3-position (closed center) valve. Wt., 1,9 kg.

**NOTE:** All valves on this page may be remote-mounted with a 9510 sub-plate. Valves 9501, 9502, 9504 and 9507 can have a port blocked or have a closed center position. When a port is blocked and the valve is shifted to the blocked port, the pump will generate excessive heat. An electric or rotary air pump can either be turned off manually or with a pressure switch. Reciprocating air pumps may be adjusted to stall out and stop.

Accessories

**3-WAY/3-POSITION (TANDEM CENTER) SOLENOID VALVES WITH POSI-CHECK®**

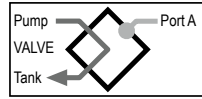
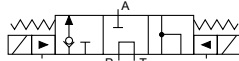
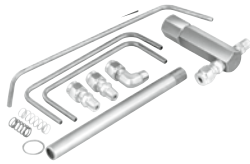
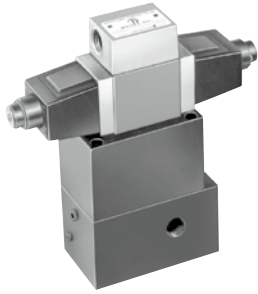

**Applications:** Single-acting cylinders.

**Actuation:** Solenoid-operated: 9605 is 115V, 50/60 Hz; 9599 is 24V, 50/60 Hz.

**Functions:** "Advance," "hold" and "return" positions. When in "advance," solenoid "B" is energized and oil goes from pump to cylinder through pressure port. In "return" position, solenoid "A" is energized and oil is directed from cylinder and pump to reservoir. With both solenoids de-energized, in "hold" position, oil from pump is directed back to reservoir while oil is checked in cylinder. The Posi-Check® feature holds load when shifting from "advance" to "hold" position.

**Used on these pumps:** Furnished with pilot lines and adapters for PE55, PE30 (carrying handles must be removed) and PE120 series. For application on other models, consult factory.

Order No.	Description
9605	3-way/3-position (tandem center) solenoid valve, 115V, 50/60 Hz. Wt., 6,4 kg.
9599	3-way/3-position (tandem center) solenoid valve, 24V, 50/60 Hz. Wt., 6,4 kg.

**NOTE:** Valves above are shipped without controls. Use 202777 remote hand control. Consult factory for field installation.

**3-WAY/4-POSITION MANUAL PRESSURE COMPENSATED VALVE**

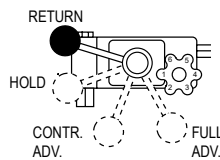
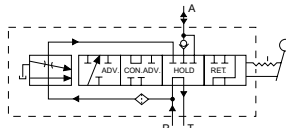
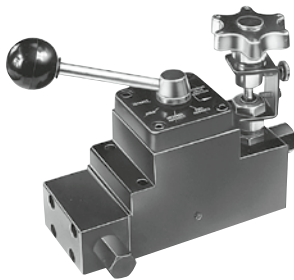

**Applications:** Single-acting cylinders. Primarily for use in testing soil, rock, concrete, asphalt and related engineering materials.

**Actuation:** Lever and adjustable, pressure compensated flow control valve.

**Functions:** Cylinder piston "return," "hold," "controlled advance" (pressure compensated) and "advance" (full flow). Will deliver a relatively constant flow regardless of pressure between 70 and 700 Bar.

**Used on these pumps:** PA17, PA46, PA55, PE17, PE21, PE30\*, PE46, PE55, PE200, PE400, PG30\*, PG55, PG120, PG400, PQ60 and PQ120 series. \* NOTE: Adapter kit 252161 is required for mounting this valve to a PE30 or PG30 series pump.

Order No.	Description
9609	3-way/4-position manual pressure compensated valve. Wt., 4 kg.



**Pressure compensated valve performance chart**

**Flow**

Full flow position - 19 l (Ref.)  
Metered advance position  
1 l/min. (Max.)

**Pressure**

Min. working pressure - 70 bar.  
Max. working pressure - 700 bar.  
Max. valve case pressure - 35 bar.

Chart to the right reflects valve performance when "metered advance" position is selected.

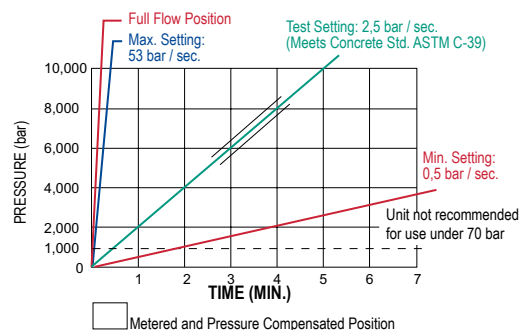

**CAUTION:** To prevent sudden, uncontrolled descent of a load as it is being lowered, use a 9596 Load-Lowering Valve or 9720 Counter Balance Valve in conjunction with the directional valve used in your application.

**IMPORTANT:** Conversion kit 251528 must be used when mounting the 9609 valve on PA17 or PE17 pumps.

**IMPORTANT:** When ordering any valve for a PE30 or PG30 series pump, 12,7 mm longer mounting screws are required. For valves 9500, 9501 and 9511, order four 12001 cap screws. For valve 9552, 9506, and 9507, order four 11956 cap screws. For valves 9599 and 9605, order four 251078 cap screws. For valve 9609, order four 10855 cap screws.

**3-WAY/2-POSITION SOLENOID VALVE**

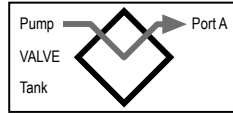
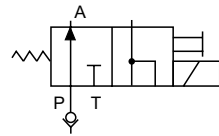

**Applications:** Single-acting cylinders.

**Actuation:** Solenoid-operated, 115V, 50/60 Hz.

**Functions:** Cylinder piston advances when solenoid is de-energized and pump is running. When solenoid is energized, oil is directed to reservoir, and piston returns. For "hold" position, pump is stopped with solenoid de-energized.

**Used on these pumps:** PE17, PE21, PE30, PE46, PE55, PE120, PE400, PQ60 and PQ120 series.

Order No.	Description
9579	3-way/2-position solenoid valve, 115V, 50/60 Hz., Wt. 4,4 kg
9569	3-way/2-position solenoid valve, 24V, 50/60 Hz., Wt. 4,4 kg
9570	3-way/2-position solenoid valve, 230V, 50/60 Hz., Wt. 4,4 kg

**NOTE:** Valves above are shipped without control switch. Use 202777 remote hand switch. When this valve is mounted, the pump must be equipped with an outlet check valve.

**3/4-WAY/2-POSITION SOLENOID VALVES**

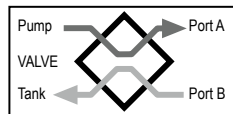
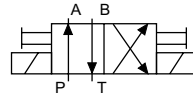

**Applications:** Single or double-acting cylinders. When used with single-acting cylinders, one port should be plugged.

**Actuation:** Solenoid-operated, 115V, 50/60 Hz.

**Functions:** Oil is directed to "extend" side of cylinder, oil from "retract" side goes to reservoir; cylinder "holds" with pump shut-off. Oil is directed to "retract" side of cylinder; oil from "extend" side goes to reservoir. **NOTE:** Cylinder will not "hold" in the "return" position with motor running or shut-off.

**Used on these pumps:** 9552, 9572 and 9592 are used with PE17, PE30 (with carrying handles removed), PE46, PE55, PE400, PQ60 and PQ120 series.

Order No.	Description
9592	3/4-way/2-position solenoid valve, 115V, 50/60 Hz., Wt. 6,6 kg
9552	3/4-way/2-position solenoid valve, 230V, 50/60 Hz., Wt. 6,6 kg
9572	3/4-way/2-position solenoid valve, 24V, 50/60 Hz., Wt. 6,6 kg

**NOTE:** Valves above are shipped without controls. The 9552, 9572 and 9592 can be used with the 304718 remote hand control.

**NOTE:** Ports are 1/4" NPTF.

**AIR ACTUATED VALVE**

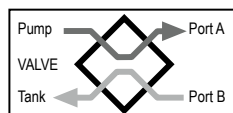
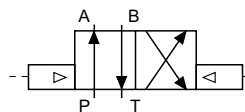

**Applications:** Single or double-acting cylinders. When used with single-acting cylinders, one port should be plugged.

**Actuation:** Air-operated.

**Functions:** Oil is directed to "extend" side of cylinder, oil from "retract" side goes to reservoir, cylinder "holds" with pump shut-off. Oil is directed to "retract" side of cylinder, oil from "extend" side goes to reservoir.

**NOTE:** Cylinder will not "hold" in the "return" position with motor running or shut-off.

**Used on these pumps:** PA17, PA46 and PA55 series.

Order No.	Description
9594	3/4-way/2-position solenoid valve, air-operated (minimum of 4 bar air pressure required). Wt., 5 kg.

**NOTE:** Valve above is shipped without controls. 9594 can be used with the 209593 remote hand control.

**CAUTION:** To prevent sudden, uncontrolled descent of a load as it is being lowered, use a 9596 Load-Lowering Valve or 9720 Counter Balance Valve in conjunction with the directional valve used in your application.

**IMPORTANT:** Conversion kit 251528 must be used when mounting any of the valves on this page on PA17 or PE17 pumps.

**IMPORTANT:** When ordering any valve for a PE30 or PG30 series pump, 12,7 mm longer mounting screws are required. For valves 9569, 9570 and 9579, order four 10856 cap screws. For valves 9552, 9572 and 9592, order four 12001 cap screws.

**4-WAY/3-POSITION (OPEN CENTER) SOLENOID VALVE**

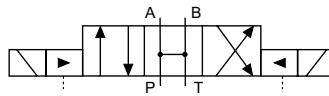
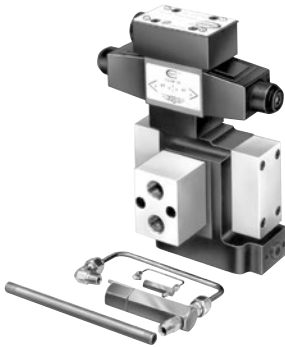

**Applications:** Double-acting cylinders.

**Actuation:** Solenoid-operated, 115V, 50/60 Hz.

**Functions:** "Advance," open center and "return" positions. Cylinder ports and pump port are open to reservoir in "neutral."

**Used on these pumps:** Furnished with pilot lines and adapters for PE30 (with carrying handles removed), PE55 and PE120 series. For other pump models, consult factory.

**NOTE:** A pressure switch and/or gauge may be attached if desired.

Order No.	Description
9590	4-way/3-position (open center) solenoid valve, 115 volt, 50/60 Hz., Wt. 7 kg.
9522	4-way/3-position (open center) solenoid valve, 230 volt, 50/60 Hz., Wt. 7 kg.
9615	4-way/3-position (open center) solenoid valve, 24 volt, 50/60 Hz., Wt. 7 kg.

**4-WAY/3-POSITION (TANDEM CENTER) PILOT-OPERATED SOLENOID VALVE**

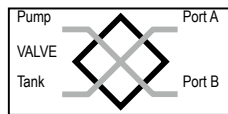
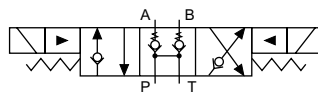

**Applications:** Double-acting cylinders.

**Actuation:** Solenoid-operated, 115V, 50/60 Hz.

**Functions:** "Advance," "hold" and "return." The Posi-Check® feature holds the load when shifting from the "advance" to the "hold" position.

**Used on these pumps:** PE17, PE21, PE30 (with carrying handles removed), PE46, PE55, PE120, PE400, PQ60 and PQ120 series.

**NOTE:** A gauge may be attached if desired.

Order No.	Description
9513	4-way/3-position (tandem center) solenoid valve, 115V, 50/60 Hz., Wt. 8,2 kg.
9512	4-way/3-position (tandem center) solenoid valve, 24V, 50/60 Hz., Wt. 8,2 kg.
9516	4-way/3-position (tandem center) solenoid valve, 12V, Wt. 8,2 kg. For use on the PG1204S and PG400 series pumps only.
9519	4-way/3-position (tandem center) solenoid valve, 230V, 50/60 Hz., Wt. 8,2 kg. Consult factory for field installation.

**3-WAY/2-POSITION (PILOT-OPERATED, NORMALLY OPEN) SOLENOID VALVE**

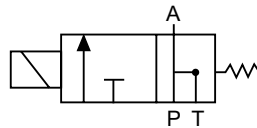

**Applications:** Single-acting cylinders.

**Actuation:** Solenoid-operated, 115V, 50/60 Hz.

**Functions:** "Advance" and "return."

**Used on these pumps:** Furnished with pilot lines and adapters for PE30 (with carrying handles removed), PE55 and PE120 series. For other pump models, consult factory.

**NOTE:** A pressure switch and/or gauge may be attached if desired.

Order No.	Description
9589	3-way/2-position (pilot-operated) solenoid valve, 115V, 50/60 Hz., Wt. 3,7 kg.
9523	3-way/2-position (pilot-operated) solenoid valve, 230V, 50/60 Hz., Wt. 3,7 kg.
9553	3-way/2-position (pilot-operated) solenoid valve, 24V, 50/60 Hz., Wt. 3,7 kg.

**CAUTION:** To prevent sudden, uncontrolled descent of a load as it is being lowered, use a 9596 Load-Lowering Valve or 9720 Counter Balance Valve in conjunction with the directional valve used in your application.

**IMPORTANT:** Conversion kit 251528 must be used when mounting the 9609 valve on PA17 or PE17 pumps.

**IMPORTANT:** When ordering any valve for a PE30 or PG30 series pump, 12,7 mm longer mounting screws are required. For valves 9513 and 9519, order four 11956 cap screws.

For valves 9523, 9553 and 9589, order four 10855 cap screws. For valves 9522, 9590 and 9615, order four 10854 cap screws.

**NOTE:** Valves above are shipped without control switch.

**4-WAY/3-POSITION (TANDEM CENTER) MANUAL VALVE**



Designed for use with Power Team air, gasoline and electric powered hydraulic pumps.

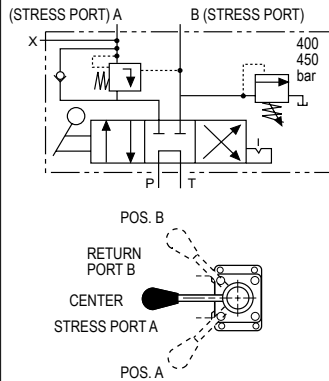

**Applications:** Single strand, double-acting stressing jacks with Power Wedge seater.

**Actuation:** Lever-operated, detent-positioned.

**Operation:**  
With valve in center position, pump is started.

Cable is inserted into stressing tool, valve is placed in "A" position. "Pull" portion of stressing tool is pressurized to specified level for proper cable tensioning ("A" port is checked internally, can only be released by building pressure in "B" position).

Valve is placed in "B" position, which is pressure controlled and will not exceed 440 bar. "Return" portion of stressing tool is pressurized and will release "A" port when pressure reaches approximately one-half the "A" port pressure. "A" port remains open as long as this pressure differential is maintained.

Pump is stopped, valve is placed in "A" position, releasing "B" port pressure.

**Used on these pumps:** PA17\*, PA46\*, PA55, PE17\*, PE21\*, PE30, PE46\*, PE55, PE60, PE120, PE400, PG30\*, PG55, PG120, PG400, PQ60 and PQ120 series.

\* These pumps may have reduced first flow stage characteristics due to internal valve restrictions.

Order No.	Description
9628	Post-tensioning valve for 700 Bar (max.) single-acting/Power Wedge seater. Wt., 2,4 kg.

**"TWIN" 4-WAY/3-POSITION (TANDEM CENTER) MANUAL VALVE**

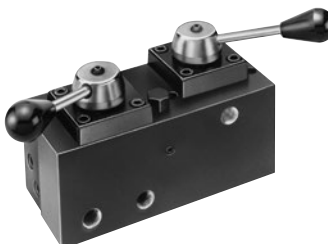

Pump-mounted, 6-position detented 5-way manual dual valve. Rated pressure to valve "A" is 700 Bar and valve "B" is 420 bar. Case pressure is 35 bar max.

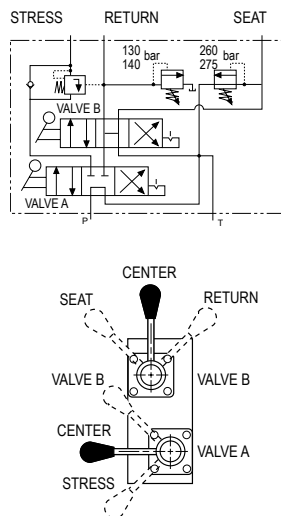

**Applications:** Multi-strand, double-acting stressing jacks with an auxiliary seating cylinder.

**Actuation:** Dual lever-operated, detent-positioned.

**Operation:**  
With valves "A" and "B" in center position, pump is started, and cable is inserted into stressing tool.

Valve "A" is placed in "Stress" position and cylinder extends to tension cable. Pump pressure controls force exerted by tensioning cylinder in this position. "Stress" port is checked internally, and can only be released by building pressure in the valve "B" return position.

When desired cable tension is achieved, valve "A" is placed in valve "B" position and valve "B" in "Seat" position. Seating portion of cylinder will be pressurized to seating pressure controlled by "Seat" relief valve (factory set to 275 bar).

Valve "B" is shifted to "Return" position, which is pressure controlled and will not exceed 155 bar. "Return" portion of stressing tool should be pressurized and will release "Stress" port when pressure reaches 15% of "Stress" port pressure.

"Stress" port will remain open and cylinder will return as long as pressure differential is maintained. "Stress" and "Seat" ports are open to reservoir.

When cylinder has fully returned, both valves are shifted to "Center" position and oil will be directed to reservoir. Maximum pressure setting for the "Seat" relief valve is 420 bar.

**Used on these pumps:** PA17\*, PA46\*, PA55, PE17\*, PE21\*, PE30, PE46\*, PE55, PE120, PE400, PG30\*, PG55, PG120, PG400, PQ60 and PQ120 series.\*

\* These pumps may have reduced first flow stage characteristics due to internal valve restrictions.

Order No.	Description
9632	Post-tensioning valve for 700 Bar (max.) double-acting systems. Wt., 6,2 kg.

**CAUTION:** To prevent sudden, uncontrolled descent of a load as it is being lowered, use a 9596 Load-Lowering Valve or 9720 Counter Balance Valve in conjunction with the directional valve used in your application.

**IMPORTANT:** Conversion kit 251528 must be used when mounting any of the valves on this page on PA17 or PE17 pumps.

**IMPORTANT:** When ordering any valve for a PE30 or PG30 series pump, 12,7 mm longer mounting screws are required. For valves 9569, 9570 and 9579, order four 10856 cap screws. For valves 9552, 9572 and 9592, order four 12001 cap screws.

**OIL COOLER KITS**

	Order No.	Description
	252511	Oil cooler kit designed for use with PE604T or PE604PT pumps with 115V. Wt., 2,3 kg.
	252512	Oil cooler kit designed for use with PE604T or PE604PT pumps with 220V. Wt., 2,3 kg.

**FLUID LEVEL/TEMPERATURE GAUGE**

	Displays fluid level and temperature of hydraulic oil in reservoir.	
	0° - 100° C. 32 mm wide and 162 mm high.	
Order No.	Description	
350431	Fluid level/temperature gauge.	

**RESERVOIR BREATHER KITS**

	Order No.	Description
	206767	Reservoir breather kit designed for use on PA17, PA55, PE17, PE55, PE120, PG55, PG120, PQ60 and PQ120 series pumps. Wt., 0,6 kg.
	250175	Reservoir breather kit designed for use on PE21 and PE46 series pumps. These kits replace the reservoir filler cap when the pump is used in dusty and dirty environments. Wt., 0,6 kg.

**CASTERS**

	50,8 mm diameter casters attach to the bottom of large reservoir for portability.	
	Sold individually. Order the amount required.	
Order No.	Description	
10494	Single caster wheel. Wt., 0,1 kg.	

**FOOT CONTROL GUARD**

	Order No.	Description
	16339	Foot Guard for use with 10461 and 251660 foot controls.

**MAGNETIC STRIP**

	Order No.	Description
	207762	Magnetic strip with adhesive back can be added to No. 25017, 202777, 202778 and 304718 hand controls. Provides 2,7 kg. of holding force. Wt., 50 g.

**VITON™ \* SEAL KITS**

	Viton™* seal kits Can be used in all "C" and "RH" series cylinders, as well as the P12, P55, P59, P157/P159, P157D/P159D and P300/P300D series of hand pumps. These seals are required when fire resistant hydraulic fluids are used. Not required with Flame-Out® fluid.		
	Order No.	Use With	Model
	300507	P12	All
	300472	P23, P55	All
	300510	P59	All
	300508	P157, P159, P300	A
	300690	P157, P159	B
	300696	P300	B
300508	P157D, P159D, P300D	A	

\* Viton™ is a trademark or registered trademark of The Chemours Company

**UNIVERSAL PUMP CART**



Mobilize your hydraulic pumps with the PC200. The rugged tubular frame can easily handle pumps weighing up to 91 kg. With 305 mm wheels, the cart rolls easily. Just load the pump onto the cart and wheel it right to the job. The universal mounting hole pattern lets you handle a wide variety of Power Team pumps.

**Cart can be used with the following pumps:** PA60, PA64 and PA554 air/hydraulic pumps; PE55 series, PE183-2 and PE184-2 electric/hydraulic pumps; PE21, PQ60 and PQ120 series "Quiet" pumps; PG55 series gas engine/hydraulic pumps; and pumps with optional 19 L- and 38 L reservoirs; Nos. RP50, RP51, RP101 and RP103.  
*(Shown with pump, pump not included)*

Order No.	Description
PC200	Universal pump cart with 305 mm wheels. Wt., 12,2 kg.

**PROTECTIVE PUMP ROLL CAGE**

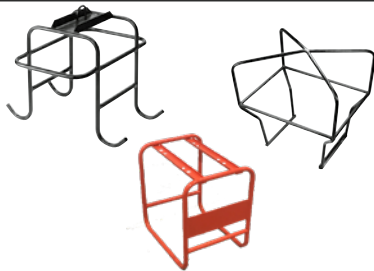

Safeguards pump, gas engine and valves on the job site. Horizontal bars provide convenient hand holds for carrying pump, a pick-up point permits lifting unit with an overhead crane or other device. Standard equipment on PG1203 and PG1204. Can be ordered as an option with any other gas, air, or electrically driven hydraulic pump equipped with a 19 liter reservoir.

**NOTE:** Refer to PG1203/PG1204 pump for details.

Order No.	Description
PC200RC	Roll cage for use with PC200. (Cannot be used on pumps with 38 liter reservoirs.) Wt., 16,3 kg.
RC2GAL	Roll cage for use with PA46, PA55, PE46, PE55 pumps with 9 liter reservoirs.
RC5	Roll cage for PG55 & PG120. For use with PG120 and PG 55 series pumps. Wt., 8,8 kg.

**Large capacity reservoirs**

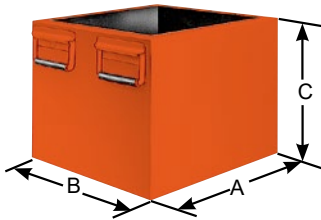

Reservoirs are equipped with drain plugs and all necessary conversion items. Hydraulic oil is not included with reservoir kits. Please order separately.

Order No.	Cap. (l)	Usable Oil (l/min)	Use With	Size (mm.)		
				A	B	C
RP20**	7,6	7,1	PA6, PA50 series (models A-E)	292	241	165
RP20-F**	7,6	7,1	PA6 series (model F), PA 50 series (model F & G)	292	241	165
RP20M*	9,5	7,2	PA6, PA50 series (models A-E)	292	241	165
RP20M-F*	9,5	7,2	PA6 series (model F), PA50 series (model F & G)	292	241	165
RP21*	9,5	7,2	PE18 series	292	241	165
RP22†	9,5	7,1	PE55, PE120, PA55	292	241	165
RP50	19,0	18,4	PE55, PE120, PA55	457	317	216
RP51	19,0	18,4	PA46, PE21	457	317	216
RP100	37,9	35,1	PE55, PE120, PA55	457	317	368
RP101	37,9	35,1	PG55, PG120	457	317	368
RP103*	37,9	37,0	PQ60, PQ120	392	362	313
RP104	37,9	35,1	PA46, PE46, PE21	457	317	356

\* Four mounting holes: 1/2"-20, for 50,4 mm diameter swivel casters (No. 10494)

\*\* High density polyethylene reservoir.

† Aluminum reservoir.

**METAL RESERVOIR CONVERSION KITS FOR PUMPS (INCLUDES GASKETS AND FASTENERS)**

Pump Number	Metal Reservoir Order Number	Metal Reservoir Capacity (l)	Reservoir Wt. (kg)	Pump Number	Metal Reservoir Order Number	Metal Reservoir Capacity (l)	Reservoir Wt. (kg)	Pump Number	Metal Reservoir Order Number	Metal Reservoir Capacity (l)	Reservoir Wt. (kg)
PA6	213896	1,7	1,4	PA50	213896	1,7	1,4	PA174	213895	9,5	4,1
PA6A	213896	1,7	1,4	PA50R	213896	1,7	1,4	PE172	213895	9,5	4,1
PA6D	213896	1,7	1,4	PA6R	213896	1,7	1,4	PE172A	213895	9,5	4,1
PA6-2	213895	9,5	4,1	PA50R2	213895	9,5	4,1	PE172S	213895	9,5	4,1
PA6D2	213895	9,5	4,1	PA172	213895	9,5	4,1	PE174	213895	9,5	4,1

Model Shown:  
**9593**

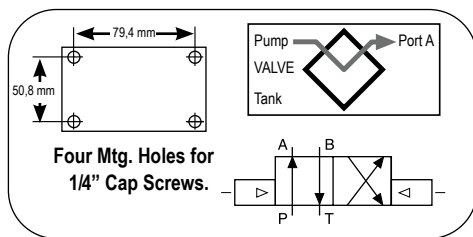

### 3/4-WAY / 2-POSITION SOLENOID ACTUATED VALVES

**Application:** Single or double-acting cylinders.

**Actuation:** 9593, 9524 and 9554 are solenoid-operated

**Operation with single-acting cylinder:** Either oil port "A" or "B" must be plugged on valve. With port "B" plugged, solenoid is energized to position "A," oil port "A" becomes pressurized. When solenoid is energized to position "B," oil port "A" becomes the return port.

**Operation with multiple single-acting cylinders:** A pressure line from one bank can be connected to oil port "A" and the other to oil port "B" on the valve. Sequence: When energized to position "A," oil port "A" becomes pressurized and clamps the fixture connected to oil port "A". Oil port "B" becomes a "return" port for cylinder connected to oil port "B," and retracts it. The opposite happens when solenoid "B" is energized.

**Operation with double-acting cylinder:** Port "A" is connected to "advance" port of cylinder, oil port "B" connects to cylinder "return" port. Solenoid is energized to position "A," oil port "A" becomes pressurized to extend cylinder piston. The opposite happens when solenoid "B" is energized. Valve does not hold in "retract" position.

**NOTE:** When using more than one valve on a pump, the tank port may require a check valve to permit inadvertent, momentary extension of a retracted cylinder.

**NOTE:** If pump is equipped with an internal outlet check, a "hold" position can be maintained with the pump shut-off.

Order No.	Description
9593	3/4-way 2-position, remote-mounted solenoid valve, 115V, 50/60 Hz., Prod. Wt. 7,0 kg.
9524	3/4-way 2-position, remote-mounted solenoid valve, 230V, 50/60 Hz., Wt. 7,0 kg.
9554	3/4-way 2-position, remote-mounted solenoid valve, 24V, 50/60 Hz., Wt. 7,0 kg.

Model Shown:  
**9595**

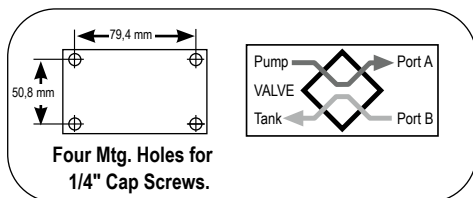

### 3/4-WAY / 2-POSITION AIR ACTUATED VALVES

**Application:** Single or double-acting cylinders.

**Actuation:** 9595 is air-operated.

**Operation with single-acting cylinder:** Either oil port "A" or "B" must be plugged on valve. With port "B" plugged, solenoid is energized to position "A," oil port "A" becomes pressurized. When solenoid is energized to position "B," oil port "A" becomes the return port.

**Operation with multiple single-acting cylinders:** A pressure line from one bank can be connected to oil port "A" and the other to oil port "B" on the valve. Sequence: When energized to position "A," oil port "A" becomes pressurized and clamps the fixture connected to oil port "A". Oil port "B" becomes a "return" port for cylinder connected to oil port "B," and retracts it. The opposite happens when solenoid "B" is energized.

**Operation with double-acting cylinder:** Port "A" is connected to "advance" port of cylinder, oil port "B" connects to cylinder "return" port. Solenoid is energized to position "A," oil port "A" becomes pressurized to extend cylinder piston. The opposite happens when solenoid "B" is energized. Valve does not hold in "retract" position.

**NOTE:** When using more than one valve on a pump, the tank port may require a check valve to permit inadvertent, momentary extension of a retracted cylinder.

**NOTE:** If pump is equipped with an internal outlet check, a "hold" position can be maintained with the pump shut-off.

Order No.	Description
9595	3/4-way 2-position, remote-mounted air-operated solenoid valve (minimum of 3,5 bar air pressure required), Prod. Wt. 5,2 kg.

**CAUTION:** To prevent sudden, uncontrolled descent of a load as it is being lowered, use a 9596 Load-Lowering Valve or 9720 Counter Balance Valve in conjunction with the directional valve used in your application.

**CAUTION:** The Posi-Check® feature will not hold the load when shifted directly A to B-B to A or from hold to A or B.

**NOTE:** Maximum tank line pressure for remote-mounted valves is 35 bar.

Model Shown:  
**9508**

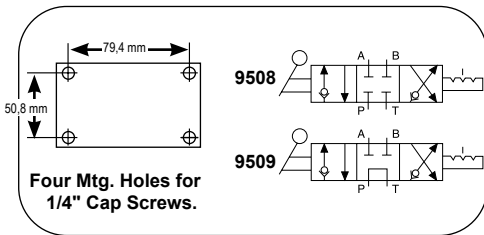
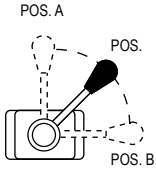

**4-WAY / 3-POSITION (CLOSED CENTER) AND (TANDEM CENTER) MANUAL VALVES WITH POSI-CHECK®**

**Application:** Single or double-acting cylinders. When used with single-acting cylinders, one port must be plugged. For double-acting cylinders, either port can be used to “advance” or “return.”

**Actuation:** Lever-operated, detent-positioned.

**Functions:** The 9508 provides “advance,” “hold” and “return” positions with all ports blocked (closed center) in the “hold” position. The 9509 has “advance,” “hold” and “return” with tandem center (cylinder ports are blocked, pump remains running). Both valves have Posi-Check® feature to guard against pressure loss when shifting from “advance” to “hold.”

Order No.	Description
9508	4-way 3-position (closed center) manual valve, including sub-plate for remote mounting. Wt., 2,9 kg.
9509	4-way 3-position (tandem center) manual valve, including sub-plate for remote mounting. Wt., 2,9 kg.

**9508**

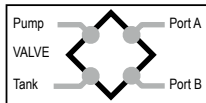

**9509**

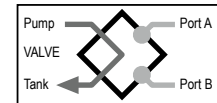

Model Shown:  
**9526**

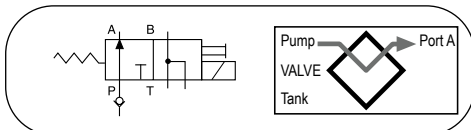

**3-WAY / 2-POSITION SOLENOID VALVE**

**Application:** Single-acting cylinders.

**Actuation:** Solenoid-operated, 115/230/24V, 50/60 Hz.

**Function:** Advances cylinder piston when solenoid is de-energized, and pump is running. When solenoid is energized, oil is directed back through valve “return” port and cylinder piston returns. To place cylinder in “hold” position, pump must be stopped or its flow held at the valve “pressure” port with the solenoid de-energized.

**NOTE:** Valve is equipped with a 9631 snubber valve in port “A.” The line from the “return” port of the valve must be unrestricted (100 bar back pressure maximum) back to the reservoir.

**IMPORTANT:** A 9580 in-line check valve must be installed in the “pressure” port if the supply pump is not equipped with an outlet check valve.

**NOTE:** Valves above are shipped without control switch. Use 202777 remote hand switch.

Order No.	Description
9559	3-way 2-position solenoid valve, 115V 50/60 Hz. Includes a remote mounting sub-plate. Wt., 4,4 kg.
9526	3-way 2-position solenoid valve, 230V 50/60 Hz. Includes a remote mounting sub-plate. Wt., 4,4 kg.
9556	3-way 2-position solenoid valve, 24V 50/60 Hz. Includes a remote mounting sub-plate. Wt., 4,4 kg.

Model Shown:  
**9514**

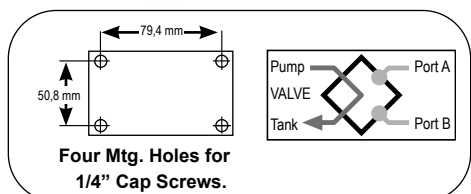

**4-WAY / 3-POSITION (TANDEM CENTER) SOLENOID VALVE WITH POSI-CHECK®**

**Application:** Double-acting cylinders.

**Actuation:** Solenoid-operated, 115/230/24V, 50/60 Hz.

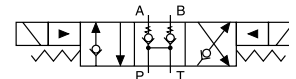

**Functions:** Push button control of “advance,” “hold” and “return.” The Posi-Check® feature guards against pressure loss when shifting from “advance” to “hold.” With valve in “hold” position, cylinder ports are blocked and oil is directed from pump to reservoir.

**NOTE:** Do not allow return tank pressure to exceed 500 bar at the valve, Consult factory before installing a pressure switch on any of these valves.

Order No.	Description
9514	4-way 3-position (tandem center) solenoid valve, 115V, 50/60 Hz. Remote hand control included. Wt., 4,6 kg.
9525	4-way 3-position (tandem center) solenoid valve, 230V, 50/60 Hz. Remote hand control included. Wt., 4,6 kg.
9555	4-way 3-position (tandem center) solenoid valve, 24V, 50/60 Hz. Remote hand control included. Wt., 4,6 kg.

**LOAD-LOWERING VALVE**

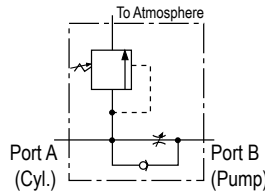

**Application:** Precision metering for controlled cylinder piston return.

**Operation:** Permits free flow when extending cylinder, built-in pressure relief and Posi-Check® locks and holds load in raised position until operator opens valve. May be pre-set to provide consistent metered return, or operator may select rate of return with each actuation. Has 3/8" NPTF ports.

**NOTE:** Pressure relief valve setting is 830 bar. Operating pressure is 700 Bar and max. flow rate is 19 l/min.

Order No.	Description
9596	Load-lowering valve. Wt., 1 kg.

**SEQUENCE VALVE**

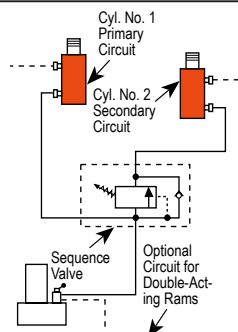
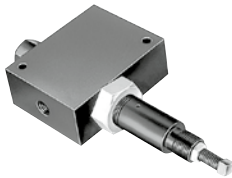

**Application:** Used when one cylinder in a multi-cylinder application must advance before any other.

**Operation:** Pump is connected to port "P" and separate cylinders to ports "A" and "B." When pressure is applied to port "P," cylinder "A" advances. Cylinder "B" will not advance until a predetermined pressure setting is reached in cylinder "A." Pressure setting is adjustable from 35 to 550 bar with adjustment screw (factory preset at 70 bar). Has 3/8" NPTF ports.

Order No.	Description
9597	Pressure control sequencing valve. Wt., 2,5 kg.

**PRESSURE REDUCING VALVE**

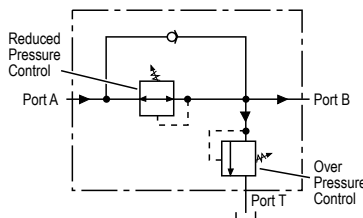

**Application:** Provides complete, independent pressure control to two or more clamping systems operated by a single power source.

**Operation:** Can be used to provide different pressures in various stages of a single system. Virtually zero leakage across valve means each system can be operated by a single continuous pressure source. Adjustable from 70 to 350 bar at outlet port "B" (secondary). Has 1/4" NPTF ports.

Order No.	Description
9608	Pressure reducing valve. Wt., 2,6 kg.

**CAUTION:** Over Pressure control must be set at a higher value than operating pressure.

**COUNTER BALANCE VALVE**

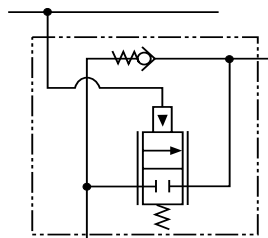

**Application:** Double-acting cylinders. Provides positive holding and controlled, "chatter-free" lowering of a load.

**Operation:** Load is raised at flow rate of pump, and held when pump is shut-off. When the pump is shifted to "retract," the counter balance valve will continue to hold the load until system pressure exceeds pressure caused by load. The load can then be lowered smoothly to the flow rate of the pump. The counter balance valve is designed to operate with pumps having a high pressure flow rate of up to 1,9 l/min. and cylinder ratios of 3 to 1.

Order No.	Description
9720	Counter balance valve, including two pairs of fittings (male and female), hydraulic hoses, and dust caps. Wt., 4,5 kg.
9721	Counter balance valve, does not include couplers, hoses, fittings and dust caps.

**CAUTION:** The 9720 patented counter balance valve has a pilot pressure as high as 210 bar. Because this pressure is applied to the rod end of the cylinder while it is already under load, the system should not be sized for loads greater than 80% of cylinder rated capacity. To prevent sudden, uncontrolled descent of a load as it is being lowered, use a 9596 Load-Lowering Valve or 9720 Counter Balance Valve in conjunction with the directional valve used in your application.

**METERING VALVE**

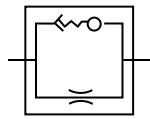

**Application:** For systems using large cylinders or extended lengths of hydraulic hose.

**Operation:** Controls surges by restricting flow if it exceeds 26,5 l/min. When flow subsides, valve reopens automatically. Has 3/8" NPTF male end to thread into return port of system control valve, and a 3/8" NPTF female end, permitting return hose to be directly connected.

Order No.	Description
9631	Metering valve. Wt., 0,1 kg.

**"IN-LINE" PRESSURE REGULATOR VALVE**

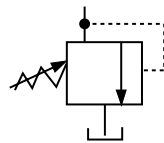

**Application:** Single or double-acting cylinders. Permits adjusting operating pressures at various values below relief valve setting of pump.

**Operation:** Regulator valve is easily adjusted to maintain pressures between 20 and 700 Bar. Maintains a given pressure setting within 3% over repeated cycles. Flow range is 0,3 l/min to 23 l/min.

Order No.	Description
9633	In-line pressure regulator valve with two 3/8" NPTF inlet ports, one 1/8" NPTF tank port and 1 m drain line kit. Wt., 1,9 kg

**RELIEF VALVE**

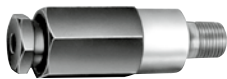

**Application:** Provide an economical means of protecting a hydraulic circuit against over pressurization.

**Operation:** These factory preset valves are designed for maximum flow rate of 19 l/min. Furnished with 1/8" NPTF male port. All valves weigh 0,1 kg. See chart below for ordering information.

**NOTE:** Care should be exercised to protect workers from hot, pressurized hydraulic oil. Install these valves only in an enclosed or shielded area.

Accessories

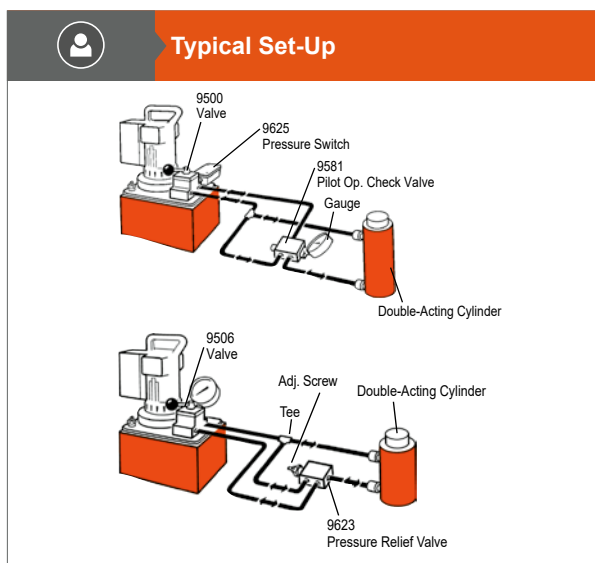

Relief Valve Order No.	Pressure Setting* (bar)
RV21278	697/738
RV21278-6	41/44
RV21278-10	62/69
RV21278-15	103/117
RV21278-17	110/124
RV21278-20	131/152
RV21278-25	159/186
RV21278-27	179/193
RV21278-28	186/207
RV21278-30	207/235
RV21278-32	214/228
RV21278-35	241/262
RV21278-38	283/310
RV21278-40	304/331
RV21278-43	338/366
RV21278-48	352/393

Relief Valve Order No.	Pressure Setting* (bar)
RV21278-50	352/393
RV21278-52	366/407
RV21278-55	386/428
RV21278-57	400/442
RV21278-60	421/462
RV21278-65	455/497
RV21278-70	490/531
RV21278-75	524/566
RV21278-80	559/600
RV21278-83	580/621
RV21278-86	600/642
RV21278-88	614/662
RV21278-90	628/669
RV21278-114	793/834
RV21278-6280	440/476

\*All RV's are Preset - Non-Serviceable

**SHUT-OFF VALVE**



**Application:** This needle valve permits fine metering of hydraulic oil  
**Operation:** Can be used for controlling multiple single-acting cylinders.

Order No.	Description
9575	Shut off valve with 3/8" NPTF ports. Wt., 0,6 kg.

**CHECK VALVE**

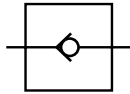

**Application:** Permits flow of hydraulic oil in one direction only.  
**Operation:** Installs right in hydraulic line.

Order No.	Description
9580	Check valve with 3/8" NPTF male ends. Wt., 0,2 kg.

**PILOT-OPERATED CHECK VALVE**

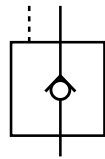

**Application:** For use with open or tandem center valves. Permits free flow of fluid in one direction.  
**Operation:** Flow is blocked in opposite direction until pilot oil pressure is applied. This prevents the loss of pressure if the valve is inadvertently shifted or the pump line is broken. Minimum cracking pressure is 4,1 bar. Required pilot pressure is approximately 16% of checked system pressure.

Order No.	Description
9581	Pilot-operated check valve with 3/8" NPTF ports. Wt., 1,7 kg.

**"IN-LINE" PRESSURE RELIEF VALVE**

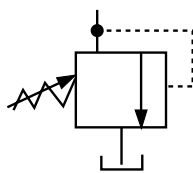

**Application:** Single or double-acting cylinders. For remote locations in a hydraulic circuit where maximum pressure requirements are less than basic overload valve setting in pump.  
**Operation:** Adjustable from 70 to 700 Bar. Valve is spring-loaded and direct-acting.

Order No.	Description
9623	Pressure relief valve with 3/8"NPTF ports. Wt. 0,9 kg.

Model Shown:  
**9639, 9638**



**Performance Requirements**

For additional technical information or to order a **Material Safety Data Sheet** go to [www.powerteam.com](http://www.powerteam.com).

**Features**

**STANDARD HYDRAULIC OIL**

- For dependable performance of all your hydraulic pumps and cylinders.
- Contains foam suppressant additives and has a high viscosity index.

**FLAME-OUT® 220 FIRE RESISTANT HYDRAULIC FLUID\***

- Contains anti-rust, anti-foam and anti-sludge additives.
- Provides fire resistant protection. Note: Will burn if heat source is extreme enough. Will not, however, propagate the flame and is self-extinguishing when there is no ignition source.
- Provides maximum lubrication and heat transfer.
- Offers a wider operating temperature range.
- No need to change seals in your Power Team equipment. Just drain the standard oil and replace it with Flame-Out® 220.

**BIODEGRADABLE HYDRAULIC FLUID**

- Biodegradable, non-toxic fluid withstands moderate to severe operating conditions. Provides excellent protection against rust.
- Offers superior anti-wear properties and has excellent multi-metal compatibility.

**LOW TEMPERATURE OIL**

- Provides smooth, reliable operation in the coldest climate conditions.

Accessories

**Technical Specifications**

Description	Grade (ASTM)	Specific Gravity @ 16°C (kg/l)	Color (ASTM)	Flash Point	Fire Point	Pour Point	Viscosity		Viscosity Index	Foam Test (ASTM)
							SUS @ 38°C	SUS @ 99°C		
Standard Oil	215	0,88	2 Amber	204°C	221°C	-34°C	215	48	100 min.	Pass
Flame-Out®	220	0,91	Light Amber	260°C	288°C	-26°C	220	55	140 min.	Pass
Biodegradable	—	0,92	2 Amber	224°C	NA*	-30°C	183	53	213 min.	Pass
Low Temp.	—	0,87	6.5 Red	180°C	204°C	-45°C	183	52	190 min.	Pass

**Ordering Information**

Order Number	Oil Description	Quantity (l)
9636	Standard Oil	0,9
9637		3,8
9638		9,5
9616		208
9639	Flame-Out®	3,8
9640		9,5
9645	Biodegradable	3,8
9646		9,5
9647	Low Temperature	3,8

**ON/OFF MOTOR CONTROL**

The following remote control switches will give you momentary "ON" control of your hydraulic pump. These switches are deadman type, spring loaded to the "OFF" position. They can be used with any Power Team electric hydraulic pump.



**25017**



**203225**



**10461**



**251660**

Order No.	Description
25017	Remote hand control. Has a push button switch, with a 3 m cord. Wt., 0,4 kg.
203225	Remote hand control. Heavy-duty with single push button switch in a neoprene housing with 3 m cord. Housing seals out dust, lint and liquids (unit is not submersible). Wt., 0,4 kg.
10461	Remote foot control, with 3 m cord. Wt., 1,4 kg.
251660	Remote foot control, with 3 m cord. For use with the PE10 style pumps. Wt., 0,5 kg.

**SOLENOID & MOTOR CONTROL**



**202777  
202778  
304718**



**309652  
309653**



**209593**



**17627  
216209**

Order No.	Description
202777*	Remote hand control. Has rocker style switch that is momentary advance, spring center hold and detented retract. It comes with a 3 m cord, for use with 3-way/2 or 3-position valves. Wt., 0,4 kg.
202778**	Remote hand control. Has rocker style switch that is momentary advance, spring center hold and momentary retract. It comes with a 3 m cord, for use with 4-way/3-position valves. Wt., 0,4 kg.
304718**	Remote hand control. Has a rocker style switch that is momentary advance, spring center hold and momentary retract. The switch is wired to start and stop the motor when the valve is energized. It comes with a 3 m cord. To be used with 4-way/2-position valves. Wt., 0,4 kg.
309653	Remote foot control. Can be used in place of either of the above hand controls to control the same type of valves. The switch is momentary on, both advance and retract position, and is spring centered to the hold position. This foot switch comes with 3 m cord. Wt., 1,8 kg.
17627	Remote foot control. Same as the 309653, but without a cord. Wt., 0,9 kg.
309652	Remote foot control. Has same functions as 304718. Supplied with a 3 m cord. To be used with 4-way/2-position valves. Wt., 1,8 kg.
216209	Remote foot control. Same as the 309652, but without a cord. Wt., 0,9 kg.

\* For use on solenoid valves that are used on single-acting cylinders

\*\* For use on solenoid valves that are used on double-acting cylinders

**NOTE:** See valves listing to determine which remote to use.

**REMOTE AIR MOTOR CONTROLS**



**209593**

This remote hand control has two momentary push buttons, one for advance and one for retract with spring offset to hold. To be used with 4-way/2-position air pilot valves.

Order No.	Description
209593	Remote hand control with 3,7 m cord. Wt., 0,9 kg.

**SUB-PLATES**

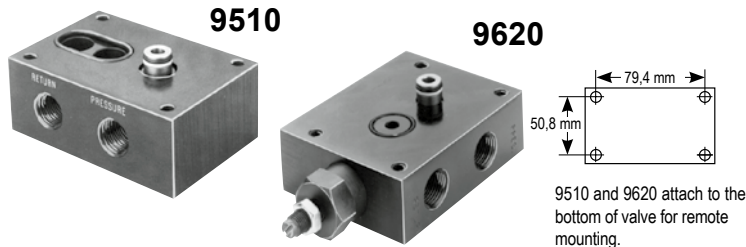

For remote mounting of control valves. Sub-plates convert pump-mounted valves to remote-mounted valves quickly and easily.

Order No.	Description
9510	Sub-plate for remote mounting the following valves; 9500, 9501, 9502, 9504, 9506, 9507, 9511, 9552, 9572, 9575, 9576, 9592 and 9594. Wt., 0,7 kg.
9620	For use with 9500, 9501, 9502, 9552, 9572, 9592 and 9594. Same as 9510, but has integral pressure regulating valve. Wt., 1,7 kg.

**PUMP-MOUNTED SUB-PLATES**

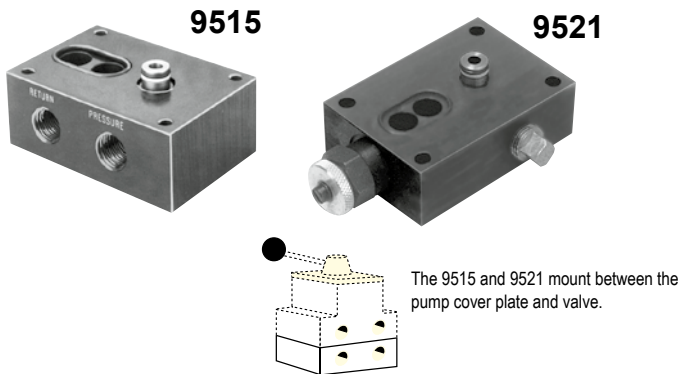

When fitted between pump cover plate, valve mounting flange, and control valve, provides a separate 3/8" NPTF female port, open to "return" regardless of position of valve. Also provides a separate 3/8" NPTF female pressure port. This sub-plate can be useful when you desire to use one pump with a deck-mounted control valve, plus a separate remote-mounted valve to control another function.

**For use with the following valves:** 9500, 9501, 9502, 9504, 9506, 9507, 9511, 9520, 9552, 9572, 9575, 9576, 9592, 9594, and 9609.

Order No.	Description
9515	Sub-plate, Wt., 0,6 kg.
9521	Sub-plate for use under most pump-mounted valves to provide adjustable pressure control on units not equipped with an external pressure regulator. Wt., 1,7 kg.

**AIR FILTER/REGULATOR/LUBRICATOR**



Recommended for use with single-speed air/hydraulic pumps.

Order No.	Description
9531	Filter/regulator. 1/4" NPTF inlet and outlet. Wt., 0,4 kg.

**PRESSURE SWITCH**

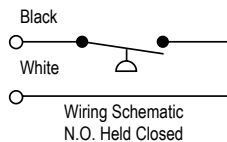

**Application:** Used in a hydraulic circuit where system pressure must be "held." Automatically (electrically) turns off pump motor when predetermined system pressure is reached.

Attaches directly to control valve manifold or can be mounted in-line to read system pressure. Has a 1/4" NPTF male thread, and a 1/4" NPTF fitting for gauge mounting if required. Adjustable from 70 to 700 Bar. Can also be used to actuate other electrical devices in the system. Wired normally open and held closed by spring pressure.

Order No.	Description
9625	In-line pressure switch with 1/4" NPTF gauge port. Wt., 0,5 kg.

**IMPORTANT:** Electrical rating of switch is 5 amps at 250V max. To prevent permanent damage to switch, a control relay must be installed to handle currents or voltage exceeding these limits. Pressure switch should never be used to directly actuate the electrical motor.

**PILOT-OPERATED AIR CONTROL VALVES**



**Application:** For use when an air pilot signal is required at a set hydraulic pressure. Can be used to shift valves, and start or stop pneumatic pumps.

Attaches directly to control manifold or can be mounted in-line to read system hydraulic pressure. Automatically turns on an air pilot signal when a predetermined system pressure is reached. Has 1/4" NPTF male thread and 1/4" NPTF fitting for gauge mounting if required. Adjustable from 35 - 700 Bar. Maximum rating of 700 l at 700 bar.

Order No.	Description
9641	Pilot-operated control valve, normally closed, with 1/4" NPTF male thread. Wt., 0,5 kg.
9643	Pilot-operated control valve, normally open, with 1/4" NPTF male thread. Wt., 0,5 kg.

Model Shown:  
**9755E**



Accessories

**Features**

**REINFORCED WIRE-BRAID RUBBER HOSES OFFER INCREASED DURABILITY**

- Hose reinforced with 4 braids of high tensile steel wire.
- The synthetic rubber covering is oil and weather resistant.
- 3/8" NPTF fittings on both ends.
- Operating pressure is 700 Bar.



**Cylinder Return Time**

Cylinder No.	9769E	9781E
	3,1 m Hose 6,4 mm I.D.	3,1 m Hose 9,5 mm I.D.
C2514C	51 sec.	14 sec.
C556C	1 min., 30 sec.	24 sec.
C5513C	4 min., 12 sec.	59 sec.
C10010C	6 min., 56 sec.	1 min. 3 sec.



**Hose with Coupler Half**

9754E Hose assembly consisting of 9756E (1,8 m hose) with 9798 (hose half coupler) and 9800 (dust cap)

**Ordering Information**

Hose Type	Hose I.D. (mm)	Hose Length (m)	Burst Rating (bar)	Order Number
Rubber, Wire-Braid	6,5	0,9	3250	9755E
Rubber, Wire-Braid	6,5	1,8	3250	9756E
Rubber, Wire-Braid	6,5	1,8	3250	9754E**
Rubber, Wire-Braid	6,5	2,4	3250	9757E
Rubber, Wire-Braid	6,5	3,1	3250	9758E
Rubber, Wire-Braid	6,5	3,7	3250	9759E
Rubber, Wire-Braid	6,5	6,1	3250	9760E
Rubber, Wire-Braid	6,5	9,1	3250	9761E
Rubber, Wire-Braid	6,5	15,3	3250	9762E

Hose Type	Hose I.D. (mm)	Hose Length (m)	Burst Rating (bar)	Order Number
Rubber, Wire-Braid*	9,5	0,9	2800	9733E
Rubber, Wire-Braid*	9,5	1,8	2800	9776E
Rubber, Wire-Braid*	9,5	3,1	2800	9777E
Rubber, Wire-Braid*	9,5	4,6	2800	9734E
Rubber, Wire-Braid*	9,5	6,1	2800	9778E
Rubber, Wire-Braid*	9,5	9,1	2800	9735E
Rubber, Wire-Braid*	9,5	12,2	2800	9736E
Rubber, Wire-Braid*	9,5	15,3	2800	9779E

\* High Flow

\*\*Furnished with 9798 hose half coupler and 9800 dust cap.

Model Shown:  
**9767E**



**Features**

**POLYURETHANE HOSES.**

- Nylon core tube with high tensile steel wire reinforcement.
- Hoses are equipped with plastic hose guards.
- Bend radius 70 mm
- Suitable for continuous service at temperatures from -40° to 100° C.



**Cylinder Return Time**

Cylinder No.	9769E	9781E
	3,1 m Hose 6,4 mm I.D.	3,1 m Hose 9,5 mm I.D.
C2514C	51 sec.	14 sec.
C556C	1 min., 30 sec.	24 sec.
C5513C	4 min., 12 sec.	59 sec.
C10010C	6 min., 56 sec.	1 min. 3 sec.



**BE SAFE!**

1. Inspect before and after each use.
2. Replace if any signs of degradation or wear that may affect safety or performance.
3. Keep the product clean.
4. Store properly.

**Ordering Information**

Hose Type	Hose I.D. (mm)	Hose Length (m)	Burst Rating (bar)	Order Number
Polyurethane	6,4	0,6	2800	9765E
Polyurethane	6,4	0,9	2800	9766E
Polyurethane	6,4	1,8	2800	9767E
Polyurethane	6,4	1,8	2800	9764E**
Polyurethane	6,4	2,4	2800	9768E
Polyurethane	6,4	3,1	2800	9769E
Polyurethane	6,4	3,6	2800	9770E
Polyurethane	6,4	6,1	2800	9771E
Polyurethane	6,4	15,3	2800	9772E
Polyurethane	6,4	22,9	2800	9750E
Polyurethane	6,4	30,5	2800	9751E

Hose Type	Hose I.D. (mm)	Hose Length (m)	Burst Rating (bar)	Order Number
Polyurethane*	9,5	1,8	2800	9780E
Polyurethane*	9,5	3,1	2800	9781E
Polyurethane*	9,5	6,1	2800	9782E
Polyurethane*	9,5	15,3	2800	9783E

\* High Flow

\*\*Furnished with 9798 hose half coupler and 9800 dust cap.

Model Shown:  
**9775**



Accessories

**Features**

**NON-CONDUCTIVE HOSE**

- For applications requiring electrical isolation.
- 3/8" NPTF fittings on both ends
- Leakage factor of less than 50 micro-ampere.
- Orange polyurethane for easy identification.
- Covering is not perforated, preventing moisture from entering the hose and affecting its overall conductivity.
- Hoses feature a minimum 2800 bar burst pressure.



**BE SAFE!**

1. Inspect before and after each use.
2. Replace if any signs of degradation or wear that may affect safety or performance.
3. Keep the product clean.
4. Store properly.



**Torque Wrench Hoses - Non-Conductive Dual Line**



Order Number	Hose Length (m)	Hose I.D. (mm)
TWH15	4,6	6,4
TWH20	6	6,4
TWH30	15,2	6,4















For torque wrench tools, refer to the tool section.

**Ordering Information**

Order Number	Couplers / Fitting	Hose I.D. (in.)	Hose Length (m)	Burst Rating (bar)
9773	3/8" Fitting NPTF	6,4	1,8	2800
9774	3/8" Fitting NPTF	6,4	3,1	2800
9775	3/8" Fitting NPTF	6,4	6,1	2800

**CYLINDER AND HOSE COUPLERS** are designed for use up to 700 bar with hydraulic jacks, cylinders, etc. They are the threaded union type for interchanging cylinders in seconds. Each half is valved with a precision ball for a tight shutoff when disconnected. These couplers also permit the separation of cylinders or hose from pump when at 0 bar with minimal oil loss.

**NO SPILL, PUSH TO CONNECT COUPLERS** are designed to permit high oil flow, the no-spill, push-to-connect couplers with locking collar and flush face design are for high pressure applications. The flush-face concept makes it easy to clean both coupler ends before connecting. Our unique push-to-connect, “dry-break” design eliminates oil spillage. The locking collar makes accidental disconnects a thing of the past. For 700 bar operation.

	Order No.	Description		Order No.	Description
	9795	Complete quick coupler with two 9800 dust caps, 3/8" NPTF.		251410	Quick-connect, screw-on female coupling. Used on 700 bar torque wrenches, nut-splitters, hoses, and pumps.  1/4" NPT Female Thread
	9798	Mail (hose) half coupler 3/8" NPTF. Includes half dust cap.		251411	Quick-connect, screw-on male nipple. Used on 700 bar torque wrenches, nut-splitters, hoses, and pumps.  1/4" NPT Female Thread
	9796	Female (cylinder) half coupler with 9800 dust cap, 3/8" NPTF.		252364	Metal dust cover for female coupler
	9796-V*	Female (cylinder) half coupler with Viton™ seals and 9797 metal dust cap, 3/8" NPTF.		252365	Metal dust cover for male coupler
	9796-E	Female (cylinder) half coupler with EPR seals and No. 9797 metal dust cap, 3/8" NPTF.		9792	No-spill, push-to-connect, Female (cylinder) half quick coupler only. (Wt., 0,14 kg.)
	9799	Optional metal dust cap (hose half).		9793	No-spill, push-to-connect, Male (hose) half quick coupler only. (Wt., 0,14 kg.)
	9797	Optional metal dust cap for cylinder half.		9794	No-spill, push-to-connect, Complete quick coupler (male and female). Dust caps not included. (Wt., 0,23 kg.)
	9800	Dust cap for male or female 3/8" NPTF half couplers. (Wt., 0,14 kg.)			

\* Viton™ is a trademark or registered trademark of The Chemours Company

Model Shown:  
**9040E**



**Accessories for Analog Gauges**



**9049 - Dampener Fitting**

High-performance pulsation dampener.  
1/4" NPTF male x 1/4" NPTF female.

**Features**

**HEAVY-DUTY HYDRAULIC PRESSURE GAUGES**

- Gauges feature an easily readable and highly visible, red Day-glo® needle.
- High strength steel bourdon tube ensures high cycle life.
- Stainless steel cases and lens locking rings.
- Have 1/4" NPT connections.
- Gauges are calibrated and comply to ASME B40.1 GRADE B



**Typical Set-Up - Mounting Situations**

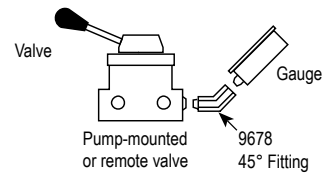
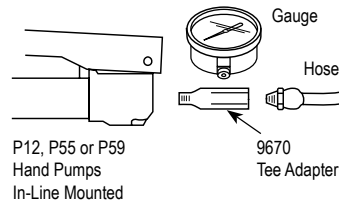

**Ordering Information**

Order Number	Face Dia. (mm)	Pressure Range (bar)	Tonnage Range (ton)	Major Graduations (bar)	Minor Graduations (bar)	Use With Cylinder Series
9040E	63,5	0 - 690	-	2000 psi, 100 bar	200 psi, 20 bar	All
9052E	101,6	0 - 690	-	1000 psi, 100 bar	100 psi, 20 bar	All
9053E	101,6	0 - 690	0-5	100 bar, 1 Ton	10 bar, 0,1 Ton	C & RLS
9055E	101,6	0 - 690	0-10	2000 psi, 1 Ton	200 psi, 0,1 Ton	C, RD, RH, RLS & RSS
9057E	101,6	0 - 690	0-15	2000 psi, 1 Ton	200 psi, 0,2 Ton	C
9059E	101,6	0 - 690	0-17,5, 0-30, 0-50	2000 psi, 5 Ton	200 psi, 0,5 Ton on 30, 50 Ton Scales; 0,2 Ton on 17,5 Ton Scale	RT172, RT302, RT503
9061E	101,6	0 - 690	0-20	100 bar, 5 Ton	10 bar, 0,5 Ton	RH, RLS, RSS
9063E	101,6	0 - 690	0-25	2000 psi 5 Ton	200 psi, 0,5 Ton	C & RD
9065E	101,6	0 - 690	0-30	2000 psi, 5 Ton	200 psi, 0,5 Ton	RH†, RLS & RSS
9067E	101,6	0 - 690	0-50	2000 psi, 5 Ton	200 psi, 0,5 Ton	RH†, RLS & RSS
9069E	101,6	0 - 690	0-55	2000 psi, 5 Ton	200 psi 0,5 Ton	C, R, RA & RD
9071E	101,6	0 - 690	0-60	2000 psi, 5 Ton	200 psi, 1 Ton	RH, except RH6010
9073E	101,6	0 - 690	0-75	100 bar, 5 Ton	10 bar, 1 Ton	C, RLS & RD8013
9075E	101,6	0 - 690	0-100	2000 psi, 10 Ton	200 psi, 1 Ton	C, R, RA, RD, RH, RLS†, RSS† & RT1004†
9077E	101,6	0 - 690	0-150	2000 psi, Initial 10 Then 20 Ton	200 psi, 2 Ton	C, R, RD & RLS
9079E	101,6	0 - 690	0-200	2000 psi, 20 Ton 10 Then 20 Ton	200 psi, 2 Ton	R, RD & RH†
9089	152,4	0 - 690	0-690	1000 psi, 100 bar	100 psi, 10 bar	All

† The tonnage scale on the gauge may vary slightly among different series cylinders due to different effective area.

Model Shown:

**LM4D-E Series**



**Features**

- The control modules are designed to be easily portable, making it suitable for various work environments.
- Equipped with female couplers on all ports, allowing it to be quickly connected to up to four hydraulic cylinders.
- Includes four silicone-filled gauges, each capable of measuring pressures up to 10,000 psi (700 bar).
- The presence of the gauges allows operators to work safely by keeping track of the hydraulic pressure within the system.
- The module is protected by a robust roll cage, which adds an extra layer of durability and protection.

**45° Gauge Adapter**

**9040GA-E**  
The Power Team 9040GA-E gauge adapters are ideal for monitoring and controlling loads. The 45° angle of the 9040GA provides easy viewing of the 2.5" (63.5 mm) gauge.

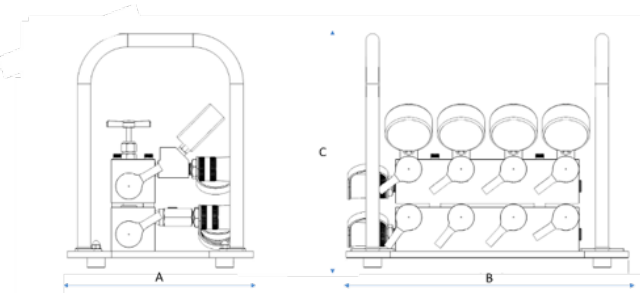

▶ The LM4 Series is ideal for simple lifting projects where safety and portability are required.



**Ordering Information**

Order Number	Description	Length (A)	Width (B)	Height (C)	Weight	Max. Operating Pressure
LM4S-E	Lifting Manifold, 4 Port, Single Acting	10.65 in / 27.05 cm	16.15 in / 41.02 cm	13.38 in / 33.97 cm	34 lb / 15.4 kg	10,000 psi (700 bar)
LM4D-E	Lifting Manifold, 4 Port, Double Acting	10.65 in / 27.05 cm	16.15 in / 41.02 cm	13.38 in / 33.97 cm	55.8 lb / 25.3 kg	10,000 psi (700 bar)

Model Shown:

9042DG, 9042DG1500



Accessories

### Features

- Digital gauge is easier to read and offers better accuracy than a conventional analog gauge.
- The laser welded stainless steel sensor & socket and the IP67 weatherproof rating make this product suitable for use in the most demanding of applications.
- Five pre-programmed engineering units allow technicians to read pressure in the unit of measure most applicable to the process.
- The gauge also features a bar graph display feature for enhanced visibility.
- Includes automatic-off battery conservation, pressure tare, minimum pressure memory and maximum pressure.
- Vibration & shock tested to MIL-STD-202G.
- Agency Compliance / Approval: RoHS, CE, ASME B40.7, UL, cUL 61010-1.
- The gauges are calibrated for life at the factory and can be certified in the field, if required.

▶ Power Team's 9042DG was the perfect choice in accurately monitoring the force applied in this H frame press application.



► **Technical Attributes**



- 1 Protective rubber boot
- 2 Back-light and large 12,2 mm display easy reading
- 3 Displays in multiple engineering units: psi, bar, mPa, inHg, kg/cm<sup>2</sup>
- 4 Weatherproof IP67 enclosure
- 5 2,000 hr. life, (2) AA (LR6) batteries
- 6 Typical Cycle Life: 10,000,000
- 7 1/4" NPTF Male Threads (9042DG); 9/16-18 UNF-2B (9042DG1500). High pressure 60° core port.

► **Technical Specifications**

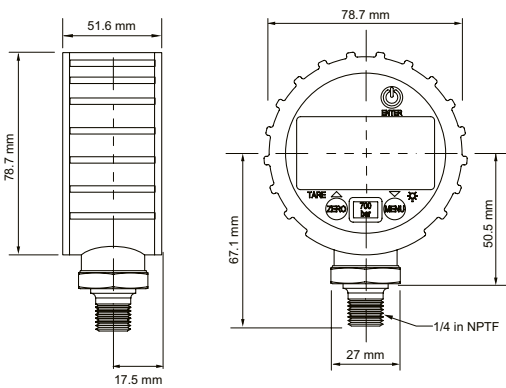

► **Ordering Information**

Order No.	Face Dia. (mm)	Rated Pressure (bar.)	Temp Range (°C)	Tool Use	IP Rating	Batteries Included	Battery Life (hrs.)	F.S. Accuracy	Prod. Weight (kg)
9042DG	63,5	0-700	-20 to +60	All	IP67	2 x AA (LR6)	2000	0.50%	0,24
9042DG1500	63,5	0-1500	-20 to +60	All	IP67	2 x AA (LR6)	2000	0.25%	0,24



**Typical Mounting Setups for 9042DG**

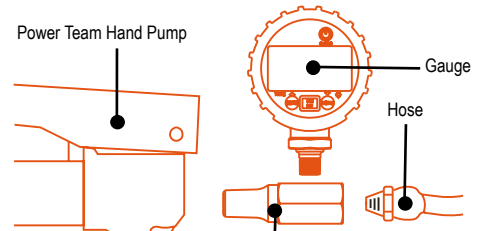

Tee adapter (No. 9670) is used for installing a gauge in line in a hydraulic circuit.

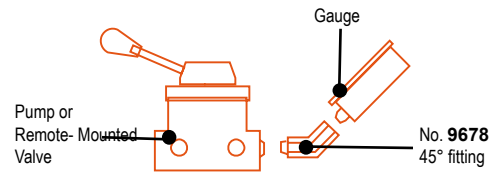

**Hardware Requirements for 9042DG**



- Does your pump have a 3/8" or 1/4" NPTF port?
- Are you direct-plumbing the gauge to your tool or seeking to quick-disconnect?
- Refer to the Power Team Catalog under the accessories section for a comprehensive range of fittings and couplers to meet your needs.





**Custom Scale**





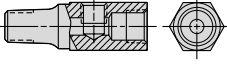
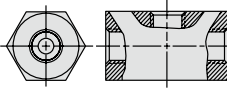
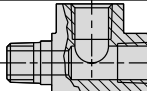
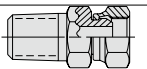
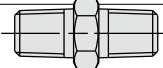
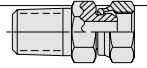

User programmable unit of measure allows you to set a custom scale to have the gauge display torque, force or weight to match the cylinder or tool being used.

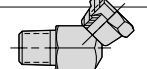
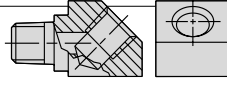
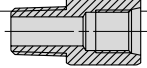
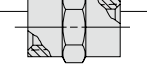
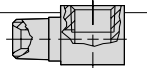
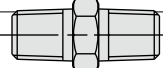
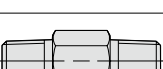

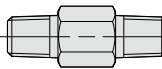
**Safety Tip**

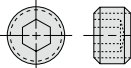
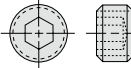
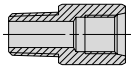
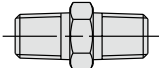
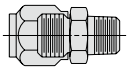
When using couplers to detach the gauge, always use a metal cover (ordered separately) on the pump side (female) coupler when the gauge is removed.

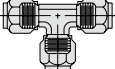
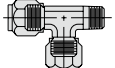
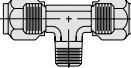
	Order No.	Description
	9190	<b>Hydraulic tubing.</b> 3/8" O.D. x .065" wall, 15,3 m. (10 pieces 1,53 m long.) Wt. 5,5 kg.
	9670	<b>Tee adapter.</b> For installing gauge between pump and hose coupling. Has 1/4" and 3/8" NPTF female and 3/8" NPTF male ports. Wt. 0,2 kg.
	9671	<b>Double tee adapter.</b> Permits use of more than one cylinder in series with one pump. Three 3/8" NPTF female ports. Wt. 0,5 kg.
	9672	<b>Service tee.</b> Two 3/8" NPTF female internal, one 3/8" NPTF male external. Wt. 0,3 kg.
	9673*	<b>Swivel connector.</b> 3/8" NPSM male, 1/4" NPSM female. Wt. 0,1 kg.
	9674	<b>Male connector.</b> 43 mm long, 1/4" x 3/8" NPTF. Wt. 0,1 kg.
	9675*	<b>Swivel connector.</b> 3/8" NPTF male, 3/8" NPSM female. Wt. 0,1 kg.
	9676*	<b>Swivel connector.</b> 1/4" NPTF male, 3/8" NPSM female. Wt. 0,1 kg.
	9677*	<b>45° swivel connector.</b> 3/8" NPTF male, 3/8" NPSM female. Wt. 0,1 kg.
	9678	<b>45° fitting.</b> Used when mounting gauge at an angle on connection such as 9670. Male and female 1/4" NPTF ends. Wt. 0,1 kg.
	9679	<b>Connector.</b> 1/4" NPTF female and 3/8" NPTF male. Wt. 0,1 kg.
	9680	<b>Coupling.</b> Both ends 3/8" NPTF female. Wt. 0,1 kg.
	9681	<b>Street elbow.</b> Male and female 3/8" NPTF ends. Wt. 0,1 kg.
	9682	<b>Male connector.</b> 43 mm long, 3/8" NPTF male ends. Wt. 0,1 kg.
	9683	<b>Male connector.</b> 57 mm long, 3/8" NPTF male ends. Wt. 0,1 kg.

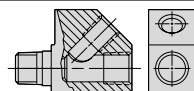
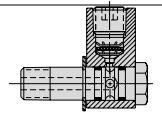





	Order No.	Description
	9684	<b>Male connector.</b> 57 mm long, 1/4" NPTF male ends. Wt. 0,1 kg.
	9685	<b>Coupling.</b> 1/4" NPTF female and 3/8" NPTF female. Wt. 0,1 kg.
	9686	<b>90° elbow.</b> 3/8" NPTF female ends. Wt. 0,2 kg.
	9687	<b>Pipe plug.</b> Heat-treated, 3/8" NPTF. Wt. 0,1 kg.
	9688	<b>Pipe plug.</b> Heat-treated, 1/4" NPTF. Wt. 0,1 kg.
	9689	<b>Connector.</b> 1/4" NPTF male and 3/8" NPTF female. Wt. 0,1 kg.
	9690	<b>Male connector.</b> 43 mm long, 1/4" NPTF male ends. Wt. 0,1 kg.
	9692	<b>Straight connector.</b> 3/8" tube x 3/8" male NPTF. Wt. 0,1 kg.
	9693	<b>90° elbow.</b> 3/8" tube x 3/8" male NPTF. Wt. 0,1 kg.
	9694	<b>45° elbow.</b> 3/8" tube x 1/4" male NPTF. Wt. 0,1 kg.
	9695	<b>Tee.</b> 3/8" tube. Wt. 0,1 kg.
	9696	<b>Male run tee.</b> 3/8" tube x 1/4" male NPTF. Wt. 0,1 kg.
	9697	<b>Male branch tee.</b> 3/8" tube x 1/4" male NPTF. Wt. 0,1 kg.
	9698	<b>Cross.</b> 3/8" tube. Wt. 0,2 kg.
	9699	<b>45° gauge fitting.</b> 3/8" NPTF male and female, and 1/4" NPTF female at 45°. Wt. 0,3 kg.
	9705	<b>Fitting, swivel.</b> 3/8" NPTF male to 3/8" NPTF female. 90° fitting with internal 370 micron screen. May be rotated 360° about male thread axis.

\* **CAUTION:** On part numbers 9673, 9675, 9676 and 9677 the female swivel end of these adapters is a straight pipe thread (NPSM) with a 30° seat. All male pipe fittings that are used with these female swivel adapters must have an internal 30° seat in order to effect a proper seal. All Power Team male fittings are manufactured with a 30° seat except 9687 and 9688.

**NOTE:** Power Team hydraulic fittings are intended for use with our high pressure hydraulic products and are suitable for use at max. working pressures of 700 Bar unless otherwise noted.



**MANIFOLD BLOCKS**

Select from a wide assortment of high pressure manifold blocks to customize your system.

	Order No.	Description
	9691	<b>"Y" Manifold.</b> Extremely useful when connecting two hydraulic cylinders to a single line. Has three 3/8" NPTF ports. Wt. 0,45 kg.
	9634	<b>Manifold block.</b> This manifold is for multiple-cylinder installations, has four 3/8" NPTF ports and two 6,4 mm mounting holes. 2" Square 1.5" thick. Wt. 0,7 kg.
	9635	<b>Manifold block.</b> This hex-shaped manifold offers extra versatility with six 3/8" NPTF ports and two 6,4 mm mounting holes. 2.5" Hex x 1.25 thick. Wt. 0,9 kg.
	9617	<b>Manifold block.</b> When a multiple-cylinder installation is required, this manifold is invaluable. Has six 3/8" NPTF ports to handle larger multiple-cylinder systems. Wt. 1,4 kg.
	9648	<b>Manifold block.</b> This 178 mm long manifold block has seven 3/8" NPTF ports and two 6,4 mm mounting holes. Wt. 1,2 kg.
	9627	<b>Manifold block.</b> This 406 mm long manifold block allows you to mount the 9575 or 9596 valves without interference. Has seven 3/8" NPTF ports and two 6,4 mm mounting holes. Wt. 2,7 kg.
	9626	<b>Pump-mounted, manifold block.</b> Converts pump-mounted valves for use with remote-mounted valves. This manifold block is sub-plate mounted on the pump cover plate and provides 3/8" NPTF pressure and return ports. Maximum recommended flow rate is 19 l/min. <b>Note:</b> If used on PE30 or PG30 series pump, 12,7 mm longer mounting screws are required. Order four (4) No. 11956 screws separately.

**MANIFOLD BLOCKS WITH NEEDLE VALVES**

For independent multiple-cylinder operation, feature needle valves for precise manual control.

	Order No.	Description
	9642	<b>2-Port Manifold.</b> Manifold with two needle valves for control of two cylinders. Has four 3/8" NPTF ports. Wt. 3,7 kg.
	9644	<b>4-Port Manifold.</b> Manifold with four needle valves for control of four cylinders. Has six 3/8" NPTF ports. Wt. 7,3 kg.

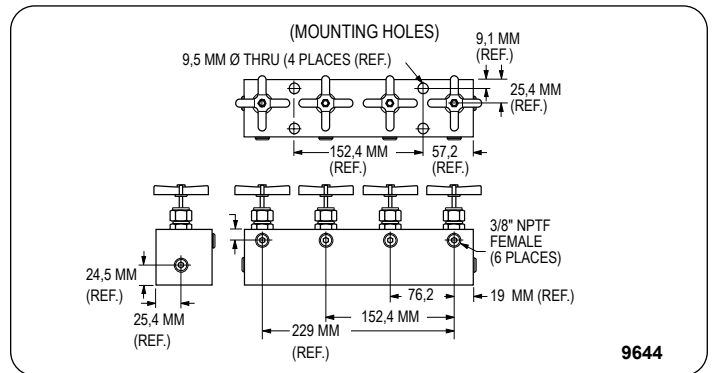
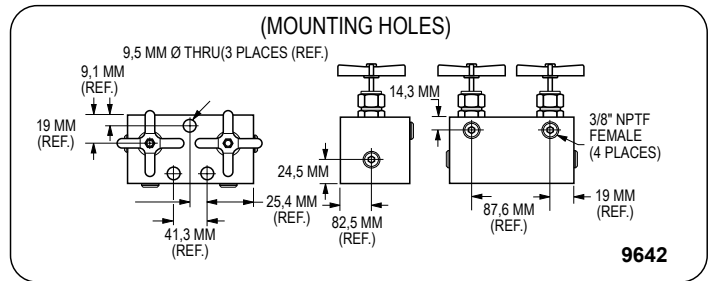

**Technical Dimensions**

Manifold Number	A (mm)	B (mm)	C (mm)
9617	177,8	38,1	38,1
9627	406,4	114,3	38,1
9648	177,8	38,1	38,1

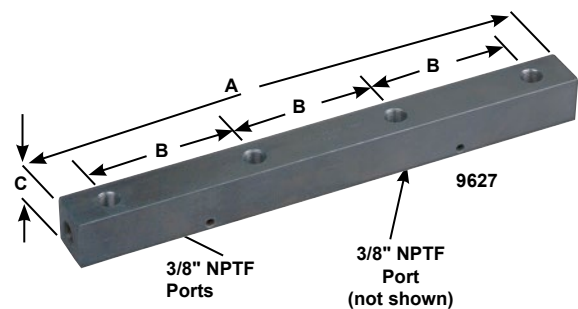

# SHOP PRESSES

Powerthon  
Limited  
**Lifetime**  
WARRANTY  
ISO 9001 Certified

Worry-Free  
Ownership

## THE PREFERRED CHOICE FOR HEAVY-DUTY, RIGID SHOP EQUIPMENT

Every piece of shop equipment goes through a detailed fabrication and assembly process, and is thoroughly inspected to ensure maximum performance in the field.

- Wide selection of H-Frame, C-Frame, and load positioning equipment to fit a wide range of applications.
- Turnkey models from available with a variety of power units ranging in manual, electric, air, and gas-driven variations.
- Array of reservoir sizes from 0,95 to 208 l.
- Valve configurations, such as dump, 2-way, 3-way and 4-way in manual and solenoid options.
- Hydraulic flow up to 6,9 l. @ 700 bar.



	<b>Section / Series</b>	<b>Shop Equipment</b>	<b>Cylinder Type</b>	<b>Tonnage Range</b>	<b>Pages</b>
	<b>Introduction</b>	—	—	—	<b>147-148</b>
	<b>SPM, SPX</b>	C-Frame	Single-Acting, Spring Return	23	<b>149</b>
	<b>SPM, SPH, SPE</b>	H-Frame	Single-Acting Double-Acting	9	<b>150</b>
	<b>SPA, SPM, SPE</b>	H-Frame Economy	Single-Acting	23	<b>151</b>
	<b>SPA, SPM, SPE</b>	H-Frame Open-End-Access™	Single-Acting Double-Acting	23	<b>152</b>
	<b>SPA, SPM, SPE</b>	H-Frame	Single-Acting Double-Acting	50	<b>153</b>
	<b>SPM, SPE</b>	H-Frame	Single-Acting Double-Acting	91	<b>154</b>
	<b>SPE</b>	H-Frame	Double-Acting	136-181	<b>155-156</b>
	<b>RB</b>	H-Frame Roll-Bed®	Double-Acting	73-181	<b>157-158</b>
	<b>AT</b>	Alignment Tools	—	—	<b>159-160</b>
	<b>FC</b>	Floor Cranes	—	—	<b>161</b>



## SELECTING THE RIGHT SHOP EQUIPMENT:

**Step 1:** What is the largest size of material you will be working with on your application?

---

**Step 2:** What capacity, or pressure, is required to perform the work?

---

**Step 3:** What is the speed, or frequency, the press will be operated. (ad-hock or production use)?

---

## SHOP EQUIPMENT SIZING CONSIDERATIONS:

Knowing how a hydraulic press operates can help you determine whether or not you need one for your application. If a press is needed, ask yourself these four questions.

1. What is the size of the largest work piece?  
For arbor and H-Frame presses, this will dictate the throat size (horizontal opening) and daylight (vertical space required).
2. What pressure is required OR what capacity is required?  
For arbor presses and H-Frame presses this will dictate how much force is required to perform the pressing operation. It is recommended to always double the tonnage required.
3. What speed and/or frequency do I need to operate the press?
4. How many parts or operations per shift is required? If the required amounts are quite high, an electric or air model power pump would be more suited verses a manual hand pump.

When selecting Power Team's Shop Equipment, you will need to select the type of press style, cylinder size and prime mover to operate and control the press.

Basic components for our shop equipment:

- A pump (or prime mover) is used to transfer the oil from a reservoir out to the tool. This can be in the form of an electric, air or manual pump.
- A control valve is used to divert or meter the flow / direction / volume of the oil out to the tool.
- A cylinder or work-head is used to fill the area above the piston cap with oil through the A-port. This forces the piston down.
- The control valve then redirects the oil either to the B-port for double-acting cylinders or diverts it back to the reservoir on spring return single-acting cylinders.



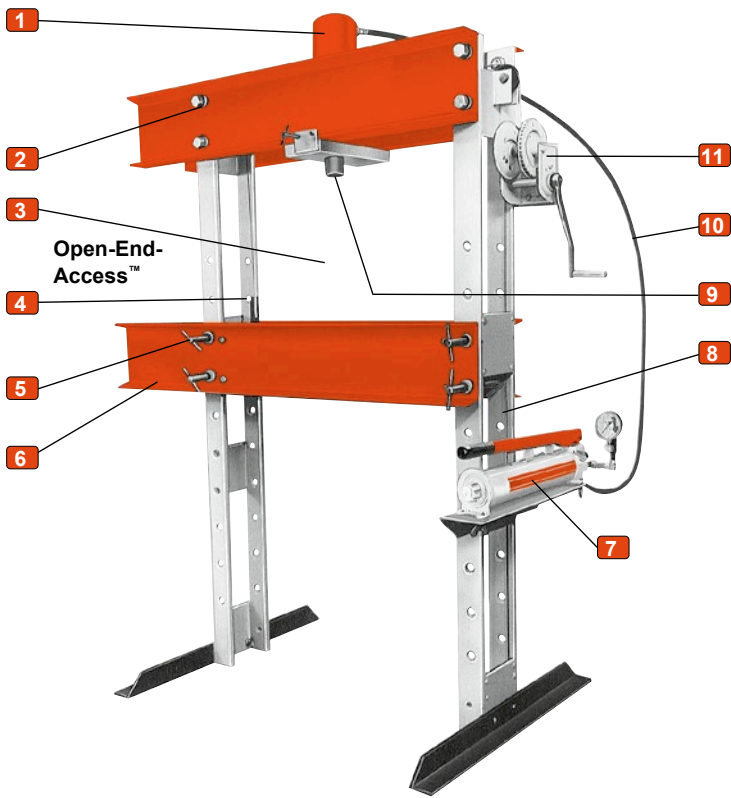

**Horizontal pressing capabilities**

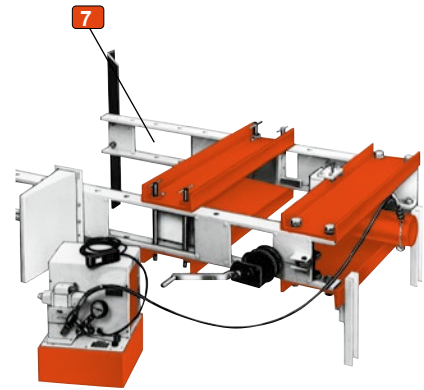

**⚠ IMPORTANT SAFETY INFORMATION:**

Power Team has protective blankets available which may afford protection from injury to users and others should part breakage occur. Power Team recommends the use of these blankets for all pushing, pulling, pressing, and lifting applications.

- 1 2 to 1 safety factor**  
Hydraulic cylinders meet ASME B30.1 standards. Single or double-acting cylinders are available.
- 2 Full rated capacity** Across width of upper frame, even with work-head moved to one side. (Heavy-duty presses only).
- 3 Larger work area** than most competitors' models.
- 4 Alignment lever** for simple pin replacement after raising or lowering the bed.
- 5 Close manufacturing tolerance** allows even load distribution over four alloy steel pins, not two, like some competitors. (Heavy-duty presses only).

- 6 Open-end-access™ feature** on 23 ton press provides additional work area by mounting cylinder on outside for C-frame advantage.
- 7 Electric, air or hand hydraulic pumps** are available. All are standard Power Team pumps. Externally-adjustable relief valve for precise operator control of working pressure is standard on all electric pumps (except PE10 and PE17 series.)  
**A 24V hand switch** for remote control on pumps equipped with solenoid valves.

**NOTE:** CSA approved electric pumps are standard on all presses.

- 8 Rugged uprights**, 50 % stronger than channel iron. Four post design means open side for easy loading of long material.
- 9 Fast cylinder approach** to work provided by 2-speed hand, air or electric pumps.
- 10 3/8" I.D. hose** on spring return cylinders on heavy-duty presses provides up to six times faster cylinder return than standard 1/4" I.D. hose.
- 11 One-Person operation** for bed adjustment. Winch unit quickly raises or lowers bed to desired height. Self-locking winch mechanism prevents bed from dropping when handle is released.

- 12 Frames can be used horizontally** for pressing jobs on extra-long shafts.
- NOTE:** Certain features do not apply to Power Team 10 ton, Roll-Bed®, or economy presses.
- NOTE:** Certain press applications may require guarding. Because of the multitude of possible press uses, it is impossible to design a guard that will meet every customer need. The end-user must provide their own guarding where the situations dictate.

Model Shown:  
**SPM256C**



Shop Equip.

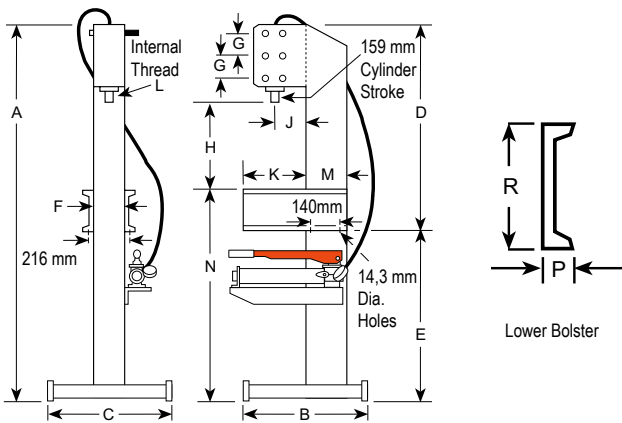

**Features**

**C-FRAME PRESSES**

- Open-End-Access™ design makes loading and unloading of work easy.
- Bench mount requires less than 1,4 sq. mm. of space.
- Cylinder head adjusts to three convenient working positions, providing up to 51 cm of “daylight.”
- Can be bench-mounted or mounted on optional base.
- Hydraulic cylinder delivers a 15 cm stroke and is driven by a P59 two-speed hand pump.

**Optional Pedestal Base**



No. 60846 – Provides a stable base for SPM256C. Includes a bracket for mounting the pump on the side of pedestal press. Only 0,37 sq. m. of floor space is needed. Wt., 34 kg.



**Technical Dimensions**

A	B	C	D	E	F	G	Cyl. Retracted		J	K	L	M	N	P	R	Floor Space	
(mm)	(mm)	(mm)	(mm)	(mm)	(mm)	(mm)	(mm)	(mm)	(mm)	(mm)	(in.)	(mm)	(mm)	(mm)	(mm)	(mm)	
1972	622	610	1057	914	152	127	260	387	514	165	318	11/2 – 16	203	1092	51	178	610 x 622

**Ordering Information**

Order No.	Cap. (tons)	Type Cyl. Used	Stroke (mm)	Cyl. Model	Speed †† Advance Pressing		Type of Pump	Pump Model	Prod. Wt. (kg)
					(mm / stroke)	(mm / stroke)			
SPM256C *	23	Single-Acting	159	C256C	3,3	0,8	Hand	P59	108

\* SPM256C does not include No. 60846 pedestal base.  
†† Typical performance based on pump specifications. Actual speeds may vary with operating conditions.

Model Shown:

**SP1010A, SPM1010**



**Features**

**H-FRAME**

- Ideal for small pressing jobs, repairing small motor armatures, removing and installing gears, bearings, other press-fit parts.
- Bench press has 391 x 457 mm work area. Floor press bed height is adjustable from 127 to 1041 mm with horizontal “daylight” of 553 mm.
- Choices of power sources include: single-speed hand pump, electric/hydraulic or air/hydraulic.
- Hydraulic gauges, hoses and fittings included.



**Pump Electrical Specifications**

PE10-220 Series – 1/4 hp, 230V, 50 cycle, single-phase.

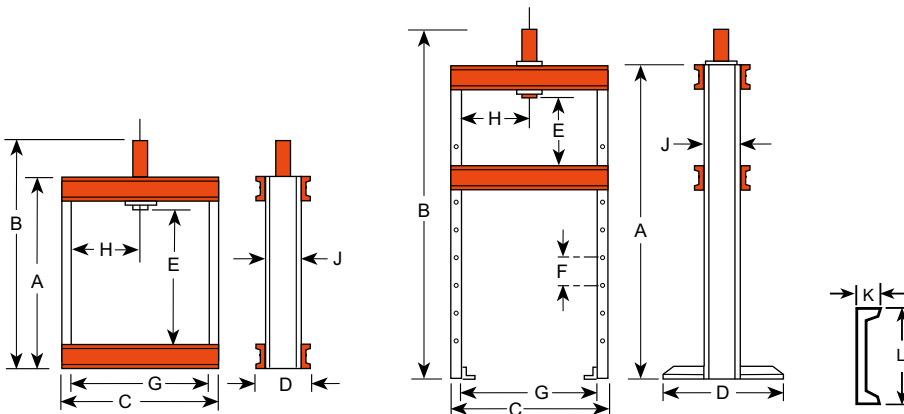

**Technical Dimensions**

Frame	A	B	C	D	E	F	G	H	J	K	L	Bench Space (mm)	Floor Space (mm)
	(mm)	(mm)	(mm)	(mm)	(mm)	(mm)	(mm)	(mm)	(mm)	(mm)	(mm)		
Bench	622	841	641	182	391	—	559	279	102	40	102	182 x 641	—
Floor	1499	1718	641	711	127-1041	152	559	63,5-470	102	40	102	—	711 x 730

**Ordering Information**

Order No.	Frame	Cap. (tons)	Type Cyl. Used	Stroke (mm)	Cyl. Model	Speed †† Advance Pressing		Type of Pump	Pump Model	Prod. Wt. (kg)
						(mm / min.)	(mm / min.)			
SPM1010	222481 Bench	9	Single-Acting	257	C1010C	1,5 mm/stroke	1,5 mm/stroke	Hand	P55	41,2
SPH1010-E220	222480 Floor	9	Single-Acting	257	C1010C	1,5 mm/stroke	1,5 mm/stroke	Hand	P55	77,5
SPE1010D-E220	222480 Floor	9	Single-Acting	257	C1010C	55,7	5,1	Elec. †	PE172-E220	79,3
SP1010A	222480 Floor	9	Single-Acting	257	C1010C	93,7	7,6	Air	PA9H	78,1
SPE1010D	222480 Floor	9	Double-Acting	257	RD1010	55,7	5,1	Elec. †	PE174-E220	87,0

† “Advance” position holds pressure with motor shut-off. “Return” position advances cylinder with motor running and returns cylinder with motor shut-off.  
 †† Typical performance based on 7 bar and 700 bar pump specifications. Actual speeds may vary with operating conditions.

Model Shown:  
**SPE256**



**Features**

**ECONOMY PRESSES**

- Rugged, yet reasonably priced. Handles many “big press” tasks, and perfect for many of the “in-between” jobs you see almost daily.
- Press bed height easily adjustable with winch. Bed will not drop when handle is released.
- Choice of power sources for rapid cylinder advance: two-speed hydraulic hand pump, electric/hydraulic or air/hydraulic. (**Note:** Stroke length limited to 159 mm on economy models).

Shop Equip.

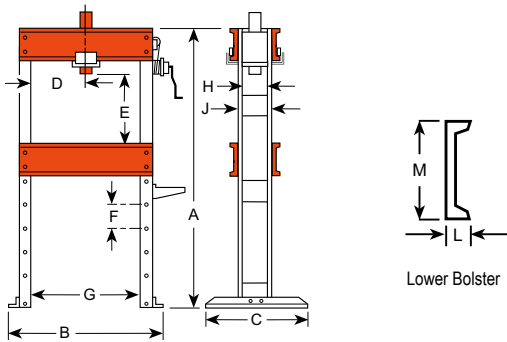

**Pump Electrical Specifications**

Pump Series	Description
PE17-220	0,4 Kw, 230V, 50 cycle, single-phase.
PE21-220	1 hp, 230V, 50 cycle, single-phase.

**Technical Dimensions**

A	B	C	D	E	F	G	H	J	K	L	M	Floor Space
(mm)	(mm)	(mm)	(mm)	(mm)	(mm)	(mm)	(mm)	(mm)	(mm)	(mm)	(mm)	(mm)
1727	1092	711	76-737	175-1102	114	813	140	165	178	64	203	1092 x 711

**Ordering Information**

Order No.	Cap. (tons)	Type Cyl. Used	Stroke (mm)	Cyl. Model	Speed †† Advance Pressing		Type of Pump	Valve Type	Pump ‡ Model	Prod. Wt. (kg)
					(mm / min.)	(mm / min.)				
SPA256	23	Single-Acting	159	SPA256	249	30	Air.	2-Way Foot	PA6	197
SPM256	23	Single-Acting	159	SPM256	3,0 mm/stroke	0,8 mm/stroke	Hand.	Load Release	P59	205
SPE256-E220	23	Single-Acting	159	SPE256	1184	84	Elec.	2-Way †	PE172-E220	210

† Holds pressure with motor shut-off. Also has an automatic dump setting. Furnished with a 3,1 m remote motor control.

†† Typical performance based on 7 bar and 700 bar pump specifications. Actual speeds may vary under operating conditions.

‡ Pump standard with press. Other Power Team pumps can be substituted. dBA at idle and 700 bar: PE172-67/81 dBA; PE21-70; dBA measured at 0,9 m distance, all sides.

Model Shown:  
**SPE2514**

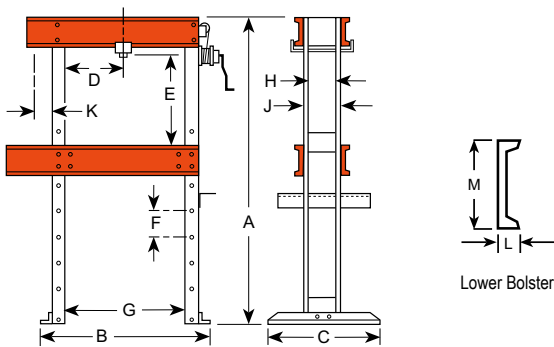

**Features**

**OPEN-END-ACCESS™ PRESSES**

- Design permits use as both H-Frame and C-Frame press. Cylinder can be mounted on frame extension to handle jobs which won't fit between uprights.
- Open-end-Access™ press models are also available with remote control to enable the operator to view work from all sides with fingertip control of cylinder piston travel.
- Off-center pressing loads of full capacity can be applied across entire width of frame.
- Press bed height easily adjustable with winch. Bed will not drop when handle is released.
- Choice of power sources for rapid cylinder advance: two-speed hydraulic hand pump, electric/hydraulic or air/hydraulic.

Pump Electrical Specifications	
Pump Series	Description
PE17-220	0,4 Kw, 230V, 50 cycle, single-phase.
PE21-220*	1 hp, 230V, 50 cycle, single-phase.

\*Not CE Compliant

Shop Equip.

**Technical Dimensions**

A	B	C	D*	E	F	G	H	J	K	L	M	Floor Space
(mm)	(mm)	(mm)	(mm)	(mm)	(mm)	(mm)	(mm)	(mm)	(mm)	(mm)	(mm)	(mm)
1727	1092	711	76-737	175-1102	114	813	140	165	178	64	203	1092 x 711

\* Lateral head movement

**Ordering Information**

Order No.	Cap. (tons)	Type Cyl. Used	Stroke (mm)	Cyl. Model	Speed ††† Advance Pressing		Type of Pump	Valve Type	Pump ‡ Model	Prod. Wt. (kg)
					(mm / min)	(mm / min)				
SPA2514	23	Single-Acting	362	C2514C	249	30	Air	2-Way Foot	PA6	309
SPM2514	23	Single-Acting	362	C2514C	12,4 mm/stroke	0,8 mm/stroke	Hand	Load Release	P159	314
SPE2514-E220	23	Single-Acting	362	C2514C	1.184	84	Electric	2-Way ††	PE172-E220	301
SPE2514S-E220	23	Single-Acting	362	C2514C	1.321	102	Electric	3-Way †	PE172S-E220	344
SPE2514DS-E220	23	Double-Acting	362	RD2514	1.321	102	Electric	4-Way †	PE174S-E220	357

† Solenoid valve with 12 volts remote control hand switch.  
 †† Holds pressure with motor shut-off. Also has an automatic dump setting. Furnished with a 3,1 m remote motor control.  
 ††† Typical performance based on 7 bar and 700 bar pump specifications. Actual speeds may vary under operating conditions.  
 ‡ Pump standard with press.  
 Other Power Team pumps can be substituted. dBA at idle and 700 bar: PE172-67/81; PE21-70; PQ60-74/76 measured at 0,9 m distance, all sides.  
**NOTE:** Frame is shipped assembled

Model Shown:  
**SPE5513DS**



Hydraulic gauge and hydraulic fittings are included with presses.

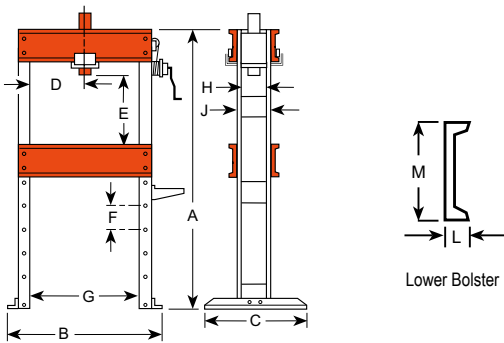

Lower Bolster

**Features**

**H-FRAME SHOP PRESS**

- Full off-center pressing at full rated capacity across width of upper frame without buckling or bending.
- Maximum "daylight" is 1067 x 914 mm, making positioning of even bulky work pieces easy.
- Height of press bed is easily adjusted with winch. Friction brake prevents bed from dropping and handle from spinning upon release.
- Presses with single-acting cylinders offer choice of 2-speed hand operated, electric/hydraulic, or air/hydraulic pump. Models with double-acting cylinders have an electric/hydraulic pump.
- Press models equipped with remote control enable operator to view work from all sides with fingertip control of cylinder piston travel.
- Press can be used horizontally for special applications with user-supplied support legs.



**Pump Electrical Specifications**

Pump Series	Description
PE55-E220	0,84 kW, 12000 rpm, 220V, 50/60 Hz universal motor.

Shop Equip.

**Technical Dimensions**

A	B	C	D*	E	F	G	H	J	L	M	Floor Space
(mm)	(mm)	(mm)	(mm)	(mm)	(mm)	(mm)	(mm)	(mm)	(mm)	(mm)	(mm)
1829	1232	914	83-832	152-1067	152	914	171	203	76	305	1232 x 914

\* Lateral head movement

**Ordering Information**

Order No.	Cap. (tons)	Type Cyl. Used	Stroke (mm)	Cyl. Model	Speed ††† Advance Pressing		Type of Pump	Valve Type	Pump ‡ Model	Prod. Wt. (kg)
					(mm / min)	(mm / min)				
SPA556	50	Single-Acting	159	C556C	114	12,7	Air	2-Way Foot	PA6	318
SPM556	50	Single-Acting	159	C556C	5,8 mm/stroke	0,4 mm/stroke	Hand	Load Release	P159	232
SPM5513	50	Single-Acting	337	C5513C	18,9 mm/stroke	0,7 mm/stroke	Elec.	2-Way	P460	435
SPE556	50	Single-Acting	159	C556C	551	38	Elec.	2-Way ††	PE172-E220	333
SPE556-E220	50	Single-Acting	337	C5513C	551	38	Elec.	2-Way ††	PE172-E220	444
SPE5513-E220	50	Single-Acting	337	C5513C	620	48	Elec.	3-Way †	PE172S-E220	478
SPE5513D-E220	50	Double-Acting	337	RD5513	551	38	Elec.	4-Way	PE174-E220	450
SPE5513DS-E220	50	Double-Acting	337	RD5513	1679	137	Elec.	4-Way †	PE554S-E220	505

† Solenoid valve with 24V remote control hand switch.

†† Holds pressure with motor shut-off. Also has an automatic dump setting. Furnished with a 3,1 m remote motor control.

††† Typical performance based on 7 bar and 700 bar pump specifications. Actual speeds may vary with operating conditions.

‡ Pump standard with press. Other Power Team pumps can be substituted. dBA at idle and 700 bar: PE172—67/81; measured at 0,9 m distance, all sides.

**NOTE:** Frame is shipped assembled.

Model Shown:  
**SPE10013DS**

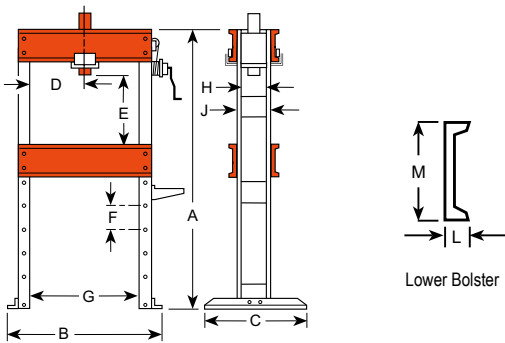

**Features**

**H-FRAME SHOP PRESS**

- Cylinder work-head glides across upper frame on rollers, locks in place for off-center pressing jobs. May be used horizontally for special pressing applications with user-supplied supports.
- Press bed is raised and lowered by winch which locks in place for insertion of bed retaining pins. Upper bolster can be lowered 203 mm for convenient positioning on repetitive jobs.
- Generous “daylight” of 1067 x 1270 mm accommodates bulky work pieces, uprights are placed for easy side entry of bars or shafts for straightening or bending.
- Choice of single or double-acting cylinder. Hydraulic pump options include: 2-speed hand pump with large 7,6 l reservoir, PE172 electric/hydraulic pump or “PQ” series “Quiet” electric/hydraulic pump with low noise level.

Pump Electrical Specifications	
Pump Series	Description
PE17-E220	0,4 Kw, 230V, 50 cycle, single-phase.
PQ120-E380	2 hp, 230V, 50 cycle, single-phase.
PQ120-220	2,24 KW, 460V, 60 cycle, three-phase.

\* To order 380V, 50 cycle, add suffix “-380” to order no.

Shop Equip.

**Technical Dimensions**

A	B	C	D*	E	F	G	H	J	L	M	Floor Space
(mm)	(mm)	(mm)	(mm)	(mm)	(mm)	(mm)	(mm)	(mm)	(mm)	(mm)	(mm)
1962	1626	914	178-1092	51-1067	203	1270	203	254	86	381	914 x 1988

\* Lateral head movement

**Ordering Information**

Order No.	Cap. (tons)	Type Cyl. Used	Stroke (mm)	Cyl. Model	Speed †† Advance Pressing		Type of Pump	Valve Type	Pump ‡ Model	Prod. Wt. (kg)
					(mm / min)	(mm / min)				
SPM10010	91	Single-Acting	260	C10010C	9,0 mm/stroke	0,3 mm/stroke	Hand	3-Way	P460	769
SPE10010-E220	91	Single-Acting	260	C10010C	889	74	Elec.	3-Way	PE552-E220	813
SPE10010R-E220	91	Single-Acting	260	C10010C	292	20	Elec.	2-Way	PE172-E220	766
SPE10013DS-E380	91	Double-Acting	330	RD10013	889	147	Elec.	4-Way †	PQ1204S-E380	854

† Solenoid valve with 24V remote control hand switch.

†† Typical performance based on 7 bar and 700 bar pump specifications. Actual speeds may vary under operating conditions.

‡ Pump standard with press. Other Power Team pumps can be substituted. dBA at idle and 700 bar: PQ120—73/78. Measured at 0,9 m distance, all sides.

NOTE: Frame is shipped assembled.

Model Shown:  
**SPE20013DS**



Hydraulic gauge and hydraulic fittings are included with presses.

Shop Equip.

**Features**

**H-FRAME SHOP PRESS**

- Standing 2,3 m tall, these giants handle the really big jobs.
- May be used horizontally for special pressing applications with user-supplied supports.
- Work-head has wide horizontal travel. Rugged press frame withstands load of rated capacity across full width of frame.
- Winch mechanism provides easy positioning of press bed, locks in place for insertion of retaining pins.
- Upper bolster can be lowered 279 mm for convenient positioning on repetitive jobs.
- Uprights are placed for easy side entry of bars or shafts for straightening or bending.
- Fast cylinder approach is provided by PQ1204S "Quiet" electric/hydraulic pump.
- Remote control hand switch, enables operator to view work from all sides with fingertip control of cylinder piston travel.

**Pump Electrical Specifications**

Pump Series	Description
PQ1204S-E380	2,24 Kw, 400V, 50Hz, three-phase.

**NOTE:** To order press with 230V, 60 cycle, single-phase pump, order press less PQ1204S. Order pump No. PQ604S separately.



Adjustable head accommodates a wide array of applications



Winch provides easy positioning of press bed



Large footing for a solid base and stability

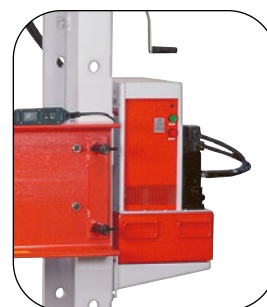

PQ120 Series pump provides the pressure and control

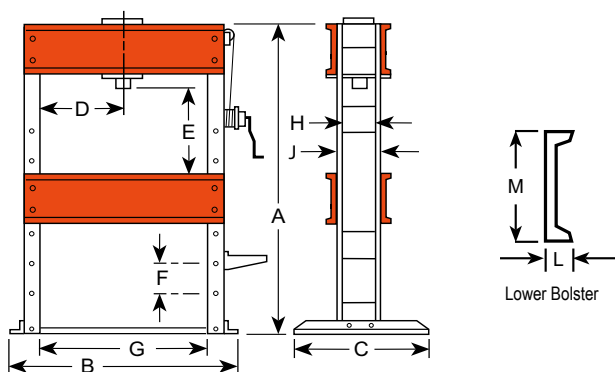

**Technical Dimensions**

A	B	C	D*	E	F	G	H	J	L	M	Floor Space
(mm)	(mm)	(mm)	(mm)	(mm)	(mm)	(mm)	(mm)	(mm)	(mm)	(mm)	(mm)
2286	1803	1118	279-991	228-1111	279	1.270	318	381	105	457	1117 x 1803

\* Lateral head movement

**Ordering Information**

Order No.	Cap. (tons)	Type Cyl. Used	Stroke (mm)	Cyl. Model	Speed † Advance Pressing		Type of Pump	Valve Type	Pump ‡ Model	Prod. Wt. (kg)
					(mm / min)	(mm / min)				
SPE15013DS-E380	136	Double-Acting	333	RD15013	610	99	Elec.	4-Way *	PQ1204S-E380	1366
SPE20013DS-E380	181	Double-Acting	333	RD20013	457	74	Elec.	4-Way *	PQ1204S-E380	1484

\* Solenoid valve with 24V remote control hand switch.

† Typical performance based on 7 bar and 700 bar pump specifications. Actual speeds may vary under operating conditions.

‡ Pump standard with press. dBA at idle and 700 bar: 73/78, measured at 0,9 m distance, all sides.

NOTE: Frame is shipped assembled.

Shop Equip.

Model Shown:  
**RB10013S**



Hydraulic gauge and hydraulic fittings are included with presses.

Shop Equip.

▶ **Roll-bell enables easy loading and unloading of large gears to simplify the pressing operation**

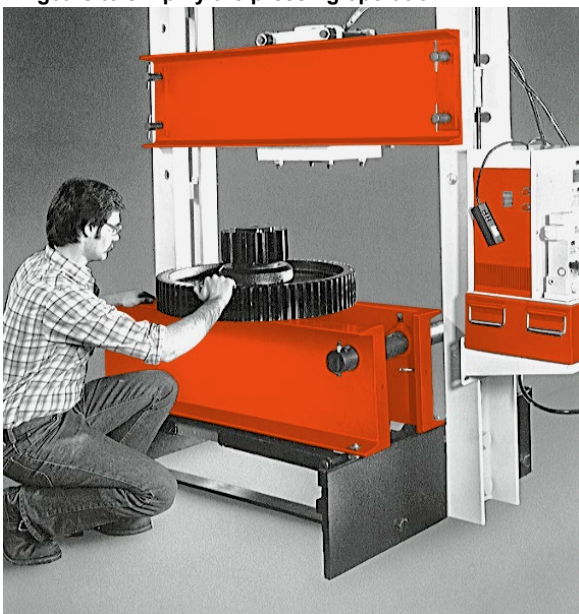

▶ **Features**

**H-FRAME ROLL-BED® PRESS**

- The original, patented Roll-Bed® extends out for easy loading and unloading with a crane or other lifting device, supporting loads up to 1361 kg.
- Movable work-head glides easily side-to-side for full off-center load capacity across width of upper frame.
- “Daylight” is 1283 x 1524 mm for 73 and 91 ton models; 1302 x 1625 mm on 136 and 181 ton presses.
- Fast approach of double-acting, 334 mm stroke cylinder is provided by PQ1204S “Quiet” electric/hydraulic pump with remote control hand switch. Operator can view work from all sides with fingertip control of cylinder piston travel.
- Adjustable lower bed width for secure balancing and centering of heavy jobs.
- Lifting mechanism has a turn crank handle to raise or lower upper bolster (a heavy-duty 1/2" drill motor can replace handle for automatic adjustment). Four locking pins hold bolster in place for pressing.



**Pump Electrical Specifications**

Pump Series	Description
PQ120	2,24 Kw, 380V, 50 cycle, three-phase.

**NOTE:** To order press with a 230V, 50 cycle, single-phase pump, order press less PQ1204S. Order pump No. PQ604S separately.

**NOTE:** Different voltage and valve options can be obtained by substituting certain PA, PE or PQ series pumps. Consult the factory.



Lifting screw and locking pins make bolster raising a one-man job.



Bearings make bed positioning smooth and easy.



Lever lowers bed for pressing, raises it for rolling.



Cylinder is easily moved across width of upper bolster.

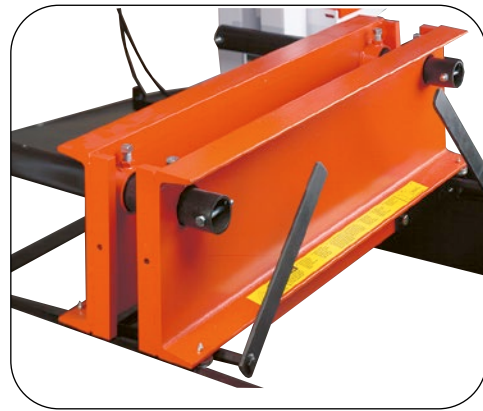

Width adjusts from 102 mm to over 686 mm; is secured with locking bolts.

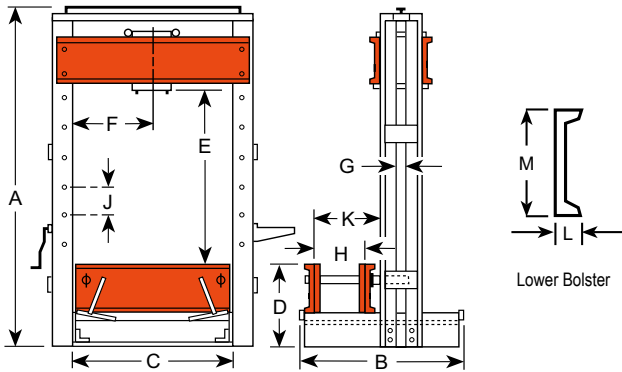

► **Technical Dimensions**

Cap. (Tons)	A (mm)	B (mm)	C (mm)	D (mm)	E (mm)	F (mm)	G (mm)	H (mm)	J (mm)	K (mm)	L (mm)	M (mm)	Floor Space (mm)
73	2861	1632	1283	686	305-1524	368-914	76,2	102-692	203	927	86	381	1632-1537
91	2861	1632	1283	686	305-1524	368-914	76,2	102-692	203	927	86	381	1632-1537
136	3131	1734	1302	762	229-1626	352-949	76,2	102-689	279	946	105	457	1734-1607
181	3131	1734	1302	762	229-1626	352-949	76,2	102-689	279	946	105	457	1734-1607

► **Ordering Information**

Order No.	Cap. (tons)	Type Cyl. Used	Stroke (mm)	Cyl. Model	Speed †† Advance Pressing		Type of Pump	Valve Type	Pump ‡ Model	Prod. Wt. (kg)
					(mm / min)	(mm / min)				
RB8013S-E380	73	Double-Acting	333	RD8013	1168	190	Elec.	4-Way †	PQ1204S-E380	1307
RB10013S-E380	91	Double-Acting	333	RD10013	889	147	Elec.	4-Way †	PQ1204S-E380	1334
RB15013S-E380	136	Double-Acting	333	RD15013	610	99	Elec.	4-Way †	PQ1204S-E380	2019
RB20013S-E380	181	Double-Acting	333	RD20013	457	74	Elec.	4-Way †	PQ1204S-E380	2059

† Solenoid valve with 24V remote control hand switch.

†† Typical performance based on 7 bar and 700 bar pump specifications. Actual speeds may vary with operating conditions. 1361 kg. maximum load can be supported on bed when raised on the rollers.

‡ Pump standard with press. dBA at idle and 700 bar: PQ120-73/78; measured at 0,9 m distance, all sides.

NOTE: Frame is shipped assembled.

Shop Equip.

Model Shown:

**PTAT-1108, PTAT-1104**

Stud Hole: 3/8" to 1-1/4" or 3/8" to 3/4"



**Features**

- Provides the ability to make precise horizontal adjustments within .001" (.025 mm).
- Portable sets allow aligning your motors, pumps, and gear boxes safe, quick, and easy.
- Eliminates the use of jack bolts, frames and heavy hammers for alignment.
- Align rotating machinery with precision.

**Ordering Information**

	ALIGNMENT TOOL RANGE			ECCENTRIC SOCKET SIZES				MOTOR APPLICATION			
	Model	Quantity	Tool Range	Socket	Quantity	Socket Size	Stud Hole	Power Range	AC Motor Frame	DC Motor Frame	
PTAT-1108	PTAT-1104	PTATN-1	2	13/16" to 1-5/8"	PTES-1	2	9/16"	3/8"	2-30 HP	182-286TS	182A-288A
		PTATN-2	2	7/8" to 2"	PTES-2	2	3/4"	1/2"			
		PTATN-3	2	7/8" to 2-5/8"	PTES-3	2	15/16"	5/8"	20-300 HP	324T-449TS	323A-368A
					PTES-4	2	1-1/8"	3/4"			
		PTATN-4	22	1-1/2" to 4-1/2"	PTES-5	2	1-5/16"	7/8"	300+ HP	5040-505S	403A-448A
	PTES-6				2	1-1/2"	1"				
	PTATN-5	22	1-7/8" to 6-1/8"	PTES-7	2	1-11/16"	1-1/8"	300+ HP	400M-8211S	503A-688A	
				PTES-8	2	1-7/8"	1-1/4"				

Shop Equip.

Model Shown:

**PTM-AT1108, PTM-AT1104**

Stud Hole: 8mm to 30mm or 8mm to 12mm



Alignment Tool



Eccentric Socket



Eccentric socket

Easy on easy off design

Precise, smooth, easy motor foot movement

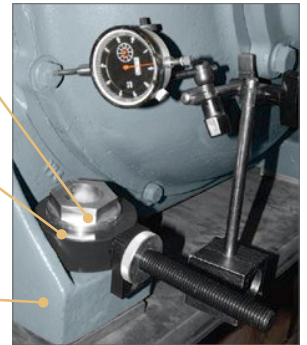

\*Kits do not include measurement devices

**Ordering Information**

	ALIGNMENT TOOL RANGE			ECCENTRIC SOCKET SIZES				MOTOR APPLICATION			
	Model	Quantity	Tool Range	Socket	Quantity	Socket Size	Stud Hole	Power Range	AC Motor Frame	DC Motor Frame	
PTM-AT1108	PTM-AT1104	PTATN-1	2	21 to 42 mm	PTES-1	2	13 mm	8 mm	1-22 kW	80-132	132-180
		PTATN-2	2	22 to 51 mm	PTES-2	2	17 mm	10 mm			
		PTATN-3	2	22 to 67 mm	PTES-3	2	19 mm	12 mm	14-224 kW	160-225	200-225
					PTES-4	2	24 mm	16 mm			
		PTATN-4	22	38 to 114 mm	PTES-5	2	30 mm	20 mm	224+ kW	250-355	250-355
	PTES-6				2	36 mm	24 mm				
	PTATN-5	22	48 to 156 mm	PTES-7	2	46 mm	30 mm	224+ kW	400	400	

Model Shown:

**PTUB200**

Stud Hole: 3/8" to 1-1/4 or 3/8" to 3/4"



**Features**

- Innovative precision undercut bolt and washer system helps reduce downtime and increase productivity
- Maximum clearance hardened grade-8 bolts along with through-hardened plated washers help to maintain perfect alignment.
- Virtually eliminate the problem of bolt binding with motor alignment.

**Includes**

Order No.	Size (in.)	Quantity
<b>Undercut Bolts (Diameter x Length)</b>		
PTU5125	5/16 x 1-1/4	12
PTU5150	5/16 x 1-1/2	12
PTU6125	3/8 x 1-1/4	12
PTU6150	3/8 x 1-1/2	12
PTU8150	1/2 x 1-1/2	12
PTU8175	1/2 x 1-3/4	12
PTU8200	1/2 x 2	12
<b>Hardened Washers (Diameter)</b>		
PTUW5	5/16	24
PTUW6	3/8	24
PTUW8	1/2	36

Model Shown:

**PTUB300**

Diameter: 9/16" to 3/4"



**Includes**

Order No.	Size (in.)	Quantity
<b>Undercut Bolts (Diameter x Length)</b>		
PTU9150	9/16 x 1-1/2	12
PTU9200	9/16 x 2	12
PTU9250	9/16 x 2-1/2	12
PTU1020	5/8 x 2	12
PTU1022	5/8 x 2-1/4	12
PTU1025	5/8 x 2-1/2	12
PTU1220	3/4 x 2	12
PTU1222	3/4 x 2-1/4	12
PTU1225	3/4 x 2-1/2	12
<b>Hardened Washers (Diameter)</b>		
PTUW5	9/16	36
PTUW6	5/8	36
PTUW8	3/4	36

Shop Equip.

Model Shown:  
**FC2200**



**Features**

**MOBILE FLOOR CRANES**

- Adjustable legs spread to clear obstacles (telescoping boom for extra reach)
- Rugged construction, reliable hydraulics.
- Boom collapses completely and legs fold for compact space-saving fold-away storage
- 2-speed hydraulic hand pump provides fast boom travel and precise operator controlled descent.
- Roller bearing wheels and a steering dolly provide ease of mobility. Lifting chain is included.
- U.S. Patent No. 3,367,512

Shop Equip.



**Ordering Information**

Order No.	Description
FC2200	1000 kg. cap. crane with fold-away feature, adj. leg spread, lifting chain and 2-speed hand pump. Wt., 206 kg.
FC4400	2000 kg. cap. crane with fold-away feature, adj. leg spread, lifting chain and 2-speed hand pump. Wt., 293 kg.

► **Technical Dimensions**

► **Features**

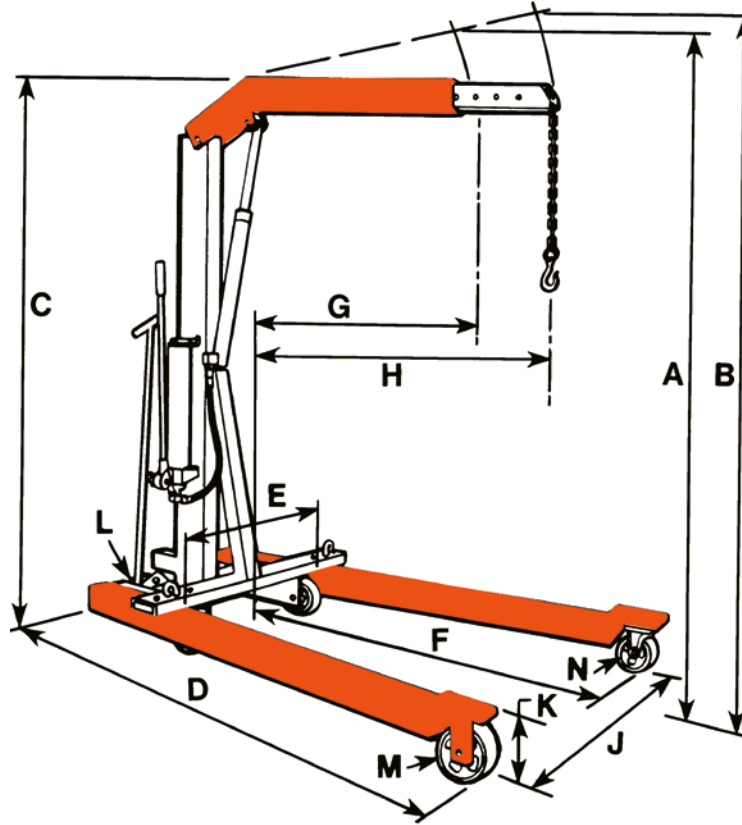

Shop Equip.

	Description	FC2200	FC4400
A	Max. boom height, ret (mm)	2718	2819
B	Max. boom height, ext (mm)	2972	3099
C	Overall height, boom horizontal (mm)	2032	2083
D	Overall length (mm)	2108	2261
E	Min. throat width (mm)	610	635
F	Inside leg length (mm)	1372	1461
G	Eff. boom reach -ret. (mm)	838	902
H	Eff. boom reach -ext. (mm)	1219	1238
J	Inside leg width (mm)	610-914-1219 (3-Position)	660-1016-1333 (3-Position)
K	Leg height (mm)	203	241
L	Dolly wheel diameter (mm)	127	127
M	Wheel diameter (mm)	152	203
N	Caster diameter (mm)	152	152
	Floor space, folded (mm)	686 x 965	787 x 1067
	Height, folded (mm)	2007	2184
	Cap. boom ret. (kg)	1000	2000
	Cap. boom ext. (kg)	750	1500

# JACKS







## SELECT FROM A WIDE RANGE OF LIFTING JACK PRODUCTS AND MAINTENANCE SETS TO COMPLETE YOUR SYSTEM REQUIREMENTS

- A hydraulic jack is a powerful lifting or pushing tool designed to provide effective lift over greater distances than a basic mechanical jack.
- Non-inflated air jacks are less than 2,54 mm thick, making lifting tasks in small spaces seem routine, tonnages up to 68 tons.
- Turnkey maintenance sets offer matched hydraulic system components, adapters and hydraulic spreader, contained in a rugged carrying and storage case.
- Specialty hydraulic jacks support post tension, low height or clearance applications.
- Portable high tonnage jacks are totally self-contained, their modular design allows you to change lifting modules to suit your tonnage or height requirements.



Powerthon  
Limited  
**Lifetime**  
WARRANTY  
ISO 9001 Certified

Worry-Free  
Ownership

	<b>Section / Series</b>	<b>Page Content</b>	<b>Tonnage Range</b>	<b>Pages</b>
	<b>Introduction</b>	Choosing the Right Jack	—	165-166
	<b>9</b>	Sidewinder Mini Jacks Low Profile Bottle Jacks Portable Hydraulic Power Bottle Jacks Telescoping Bottle Jacks	4,5 - 18 11, 18 & 27 2 - 100 5-12	167 168 169 170
	<b>J</b>	Economy Toe Jacks	5, 10 & 25	171
	<b>M</b>	Maintenance Sets	2 & 9	172
	<b>RJ</b>	Portable Railroad Edition Jacks and Accessories	91	173-174
	<b>JE / JA</b>	Portable High Tonnage Railroad Jacks and Accessories	50, 91, 130	175-176
	<b>SK</b>	10 and 25 Ton Start-Up Kits	9 & 23	177-178
	<b>SJ</b>	Post-Tension and Stressing Jacks and Accessories	18 & 27	179-180



## SELECTING THE RIGHT JACK:

**Step 1:** Select the style jack that best suits the application and your intended lift.

**Step 2:** How much clearance, or open space, is available? What is the minimum height?

**Step 3:** How much lift, or extension, is required for the load? What is the tonnage needed?

## JACK SIZING CONSIDERATIONS:

### 1. What do you need to lift?

Depending on the vehicle or machine you need to lift, you will require appropriate equipment. You don't lift a 18 ton truck with the same equipment you would use to lift a 2 ton vehicle.

To choose the right fit, first look at the hydraulic jack capacity. Today, on the market, you can find various sizes of hydraulic jacks, with a lifting capacity going from 1 ton to 272 tons, and even more.

### 2. What is the free space available?

The best jack in the world is useless if you can't place it under the load. Nowadays, application start height is getting lower and lower, requiring a more compact equipment.

Ground clearance is an important parameter to consider, you need to be able to place the jack without damaging the load.

### 3. What is the maximum lifting height you would need?

To make the best choice, compare the number of strokes and maximum height of each hydraulic jack.

In addition, ask the how many extensions are available with the hydraulic jack. Some of the equipment has 1 or 2 additional extensions, which will cover more applications with the same equipment.

## JACK SERIES:

### Hydraulic Bottle Jacks

Choose from this complete line of premium quality, standard bottle jacks. Ideal for use in any number of industrial lifting and pushing applications.

Tonnage Range: 2-100





**Maintenance Sets**

Matched hydraulic system components, adapters and a hydraulic spreader, contained in a rugged carrying and storage case. Portable sets are ideal for pushing, pulling, lifting, straightening, or clamping at remote job sites.

Types: Manual or electric drive maintenance sets

Tonnage Range: 9 - 23



**Portable High Tonnage Jacks**

Totally self-contained, modular design allows you to change lifting modules to suit your tonnage or height requirements.

Tonnage Range: 50 - 272

Model Shown:

9210A, 9220A, 9105A, 9205A



Features

COMPACT SIDEWINDER MINI JACK FITS IN YOUR PALM AND DELIVERS 4,5 , 9 & 18 TONS OF LIFTING FORCE.

- Retracted height of just 63,5 mm for the smallest jack and 130,2 mm for the 18 ton, allows you to slip this jack into the narrowest of crevices.
- Jacks operate either horizontally or vertically. Handles function in line with base for easier use in confined spaces.
- The perfect addition to any toolbox, this remarkable little jack has multiple uses that are limited only by your imagination. Use it as a jack, or a spreader. Use it to turn your mechanical gear puller (note: puller capacity must match jack capacity) into a hydraulic puller.
- High strength piston and pump linkage for long life.
- All models include over-travel protection.
- Lever Bar included on all models.
- All jacks meet ASME B30.1 standards and carry the Power Team PowerThon™ Lifetime Warranty.

9105A Sidewinder jack is the ideal choice for straightening this crushed box steel .



Ordering Information

Order Number	Cap. (tons)	Stroke (mm)	Retracted Height (mm)	Max. Height (mm)	No. Pump Strokes to Ext. Piston	Saddle Dia. (mm)	Base Size Dia. (mm)	Pump Handle Length (mm)	Handle Effort at Rated Cap. (kg)	Carry Handle	Metric Tons @ 700 bar	Prod. Wt. (kg)
9105A	4,5	19	63,5	85,9	30	29,0	73,9	240	26	No	4,5	1,9
9205A	4,5	38	88,9	130,3	38	29,0	73,9	240	26	No	4,5	2,4
9210A	9	30	120,7	149,4	36	42,2	110,0	440	28	No	9,2	5,5
9220A	18	30	130,3	160,3	46	52,8	119,9	605	35	No	18,1	8,0

Note: Jacks are not serviceable, other than handle.

Model Shown:

**9012A, 9020A, 9130A**



**Features**

**THE RIGHT CHOICE FOR THOSE LOWER CLEARANCE JOBS OR APPLICATIONS**

- All the quality, features and lifting capacity of the standard jacks in short form. The 11 ton and 18 ton models feature screw extensions for added versatility.
- All jacks operate both vertically and horizontally for use in a variety of lifting, pushing and spreading applications.
- Large base area for increased strength and stability during lifting.
- High strength piston and pump linkage for long life.
- All models include over-travel protection.
- Lever Bar included on all models.
- All jacks meet ASME B30.1 standards and carry the Power Team PowerThon™ Lifetime Warranty.

▶ **9130A Low Profile Hydraulic Bottle Jack provides the lifting capacity and low height for this underground mining application.**



Jacks

**Ordering Information**

Order Number	Cap. (tons)	Stroke (mm)	Retracted Height (mm)	Length of Screw Ext. (mm)	Height with Screw Ext. (mm)	No. Pump Strokes to Ext. Piston ‡	Saddle Dia. (mm)	Base Size (mm)	Pump Handle Length (mm)	Handle Effort at Rated Cap. (kg)	Carry Handle	Metric Tons @ 700 bar	Prod. Wt. (kg)
9012A	11	95	171	76	343	26	48	165x106	605	27	Yes	10,9	6,4
9020A	18	85	181	40	305	22	51	183x129	800	32	Yes	18,1	10,1
9130A	27	79	181	-	260	35	60	192x141	1000	23	Yes	27,2	13,7

‡ 2 Speed: Rapid advance≈40 strokes; Lift mode≈160 strokes.

Note: Jacks are not serviceable, other than handle.

Model Shown:

9030A, 9008A, 9112A



**Features**

**IDEAL FOR INDUSTRIAL LIFTING AND PUSHING APPLICATIONS FOR MRO**

- Choose from this complete line of premium quality bottle jacks. Ideal for use in any number of industrial lifting and pushing applications.
- The 9110B, 9015B, 9022B and 9033B feature a beveled base which allows the jack to “follow” the load, reducing the chance of dangerous side-loading.
- Jacks feature a screw extension for quicker setup.
- High strength piston and pump linkage for long life.
- All models include over-travel protection.
- Lever Bar included on all models. All jacks can be used in the vertical, angled or horizontal positions.
- Serrated or contoured saddles help stabilize the load for a safer lift.
- 100 ton jack features dual pumps for time-saving two-speed operation.
- Not CE Compliant
- All jacks meet ASME B30.1 standards and carry the Power Team PowerThon™ Lifetime Warranty.

**Ordering Information**

Order Number	Cap. (tons)	Stroke (mm)	Retracted Height Min. (mm)	Length of Screw Ext. (mm)	Height with Screw Ext. (mm)	No. Pump Strokes to Ext. Piston	Saddle Dia. (mm)	Base Size (mm)	Pump Handle Length (mm)	Handle Effort at Rated Cap. (kg)	Carry Handle	Metric Tons @ 700 bar	Prod. Wt. (kg)
9002A	2	114	181	49	344	5	25	110x65	311	34,0	No	1,8	2,2
9003A	3	114	191	60	365	10	29	114x72	489	20,4	No	2,7	2,6
9005A	4,5	121	200	70	391	12	35	132x76	545	24,9	No	4,5	3,6
9008A	7	121	200	70	391	18	38	152x89	605	34,0	No	7,3	5,5
9112A	11	149	241	80	470	26	48	165x106	605	27,2	Yes	10,9	7,9
9015B	14	156	230	114	505	27	60	130x140 †	700	40,8	No	13,6	8,3
9120A	18	159	270	92	521	22	51	183x129	800	31,8	Yes	18,1	12,9
9022B	20	156	240	109	521	36	60	165x160 †	700	40,8	Yes	20,0	10,7
9030A	27	159	279	—	438	35	60	192x141	1000	22,7	Yes	27,2	18,7
9033B	30	143	240	106	502	56	65	184x176 †	700	39,9	Yes	29,9	14,5
9050A	45	171	305	—	476	36	76	237x187	1000	38,6	Yes	45,4	35,4
9110B	100	156	300	—	456	40/160 ‡	111	339x291	700	35,8	Yes	99,8	70,0

† Comes with a Beveled Base.

‡ 2 Speed: Rapid advance≈40 strokes; Lift mode≈160 strokes.

Note: Jacks are not serviceable, other than handle.

Model Shown:

**9006X, 9011X, 9013X**



**Features**

**THE RIGHT CHOICE FOR THOSE LOWER HEIGHT APPLICATIONS FOR MRO.**

- Telescoping jacks offer all of the quality features and capabilities of the standard bottle jack line with a bonus. The super-long stroke of these jacks saves time and effort by eliminating the need to lift or crib. In most applications, the user can place the jack once and complete the lift.
- The 9006X, 9011X, 9012X, and 9013X all feature a unique beveled base that allows the jack to “follow” the load laterally as it is raised, greatly reducing side-loading of the piston.
- High strength piston and pump linkage for long life.
- All models include over-travel protection.
- Lever Bar included on all models.
- All jacks meet ASME B30.1 standards

**Ordering Information**

Order Number	Cap. (tons)	Stroke (mm)	Retracted Height (mm)	Length of Screw Ext. (mm)	Height with Screw Ext. (mm)	No. Pump Strokes to Ext. Piston	Saddle Dia. (mm)	Base Size Beveled Base (mm)	Pump Handle Length (mm)	Handle Effort at Rated Cap. (kg)	Carry Handle	Metric Tons @ 700 bar	Prod. Wt. (kg)
9006X	5	305	216	—	512	14	44	121x133	700	36	No	5,4	6,4
9011X	10	262	200	68	530	25	41	160x165	700	40	No	10	8,8
9012X	11	305	230	120	620	-	50	185x144	700	39	Yes	11	13
9013X	12	254	230	84	570	35	48	176x186	700	36	Yes	11,8	11,3

Note: Jacks are not serviceable, other than handle.

Model Shown:

**J24T, J55T, J106T**

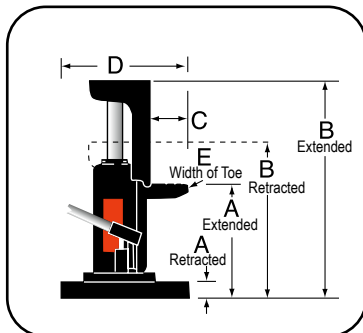

**Features**

**LOW HEIGHT INDUSTRIAL LIFTING AND PUSHING APPLICATIONS.**

- These bottle jack-style toe jacks are loaded with many of the same features as our standard bottle jacks, but the toe-lift feature and swiveling pump handle socket make them ideal for machinery lifting and positioning.
- An internal pressure relief provides added safety by limiting the jack's lifting capability to the capacity of the toe.
- Spring return is an added feature on the J55T and J106T jacks.
- Swiveling pump handle assembly available on the 5 and 10 ton models. The swiveling jack assembly allows you to access and pump the unit from numerous positions.
- High strength piston and pump linkage for long life.
- All models include over-travel protection.
- Lever Bar included on all models.
- All jacks meet ASME B30.1 standards and carry the Power Team PowerThon™ Lifetime Warranty.

**Technical Dimensions**

Order Number	Ret.	Ext.	Ret.	Ext.	C (mm)	D L x W (mm)	E (mm)
	A		B				
	(mm)	(mm)	(mm)	(mm)			
J24T	16,0	139,7	235,0	355,6	47,8	283 x 240	50,8
J55T	25,4	149,4	292,1	416,1	47,8	283 x 240	76,2
J106T	31,8	181,1	327,2	476,3	63,5	283 x 240	100,1

**Ordering Information**

Order Number	Cap. (tons)	Max. Lift Stroke (mm)	Strokes to Ext. Piston (25 mm)	Handle Effort at Max. Load (kg)	Carry Handle	Metric Tons at 700 bar	Prod. Wt. (kg)
J24T	2	121	14	19	Yes	1,8	8,3
J55T	4,5	121	22	27	Yes	4,5	24,0
J106T	9	146	31	33	Yes	8,1	38,0

Note: Jacks are not serviceable, other than handle.

Model Shown:  
**IM10E, IM10H**



NOTE: Actual storage box may differ from photo.

**Features**

**TURNKEY, EXTREMELY VERSATILE MECHANICS MAINTENANCE KIT FITS MANY APPLICATIONS.**

- Matched hydraulic system components, adapters and hydraulic spreader, contained in a rugged carrying and storage case.
- Portable sets are ideal for pushing, pulling, lifting, straightening, or clamping at remote job sites.
- Cylinders in set are rated at 9 tons at 700 bar. Set components are designed for full rated capacity of cylinders.
- Set IM10H/IM10L includes hand operated pump. Set IM10E includes the Quarter Horse® electrically driven portable power unit.



**Application Flexibility**

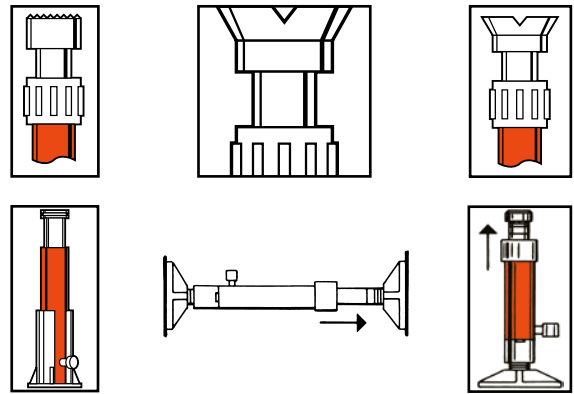

Jacks

**Ordering Information**

Order No.	IM10B	IM10E
<b>CONTENTS OF SET</b>	<b>Items Included below</b>	<b>Items Included below</b>
Hydraulic spreader	HS2000	HS2000
Hand pump (electric)	PB102-1	PE102
Hydraulic gauge (700 bar)	9041	9041
Tee adapter	9670	9670
Hose & coupler assembly	9754	9754
90° V base	25395	25395
Threaded coupler	25664	25664
Serrated saddle	31772	31772
Flat base	32325	32325
Extension rod - 127 mm length	350897	350897
Extension rod - 254 mm length	38909	38909
Extension rod - 457 mm length	350898	350898
Cylinder support base	420062	420062
Cylinder, 10 ton, 257 mm stroke	C106CBT	C106CBT
Cylinder, 10 ton, 156 mm stroke	C1010CBT	C1010CBT
Storage box	350722	350722
Prod. Weight (kg)	48,1	48,1

Order No.	IM10H	IM10L
<b>CONTENTS OF SET</b>	<b>Items Included Below</b>	<b>Items Included Below</b>
Hydraulic spreader	HS2000	HS2000
Hand pump	P59	P59L
Hydraulic gauge (700 bar)	9041	9041
Tee adapter	9670	9670
Hose & coupler assembly	9754	9754
90° V base	25395	25395
Threaded coupler	25664	25664
Serrated saddle	31772	31772
Flat base	32325	32325
Extension rod - 127 mm length	350897	350897
Extension rod - 254 mm length	38909	32890
Extension rod - 457 mm length	350898	350898
Cylinder support base	420062	420062
Cylinder, 10 ton, 156 mm stroke	C106CBT	C106CBT
Storage box	350722	350722
Prod. Weight (kg)	40,4	36,8

Model Shown:  
**RJ100T24E**



**HEAVY-DUTY SELF-CONTAINED INDUSTRIAL LIFTING JACK FOR RAIL MAINTENANCE.**

- Wide base cylinder design for stability.
- Double-acting cylinder with locking collar.
- The bottom of the cylinder is a bolted joint, using the base plate as part of the cylinder. This will allow for service of even the oldest or most abused jacks.
- Cribbing storage rack location is such that it allows easy access during cribbing placement and removal.
- Jack has a 6,1 m remote pendant for user safety and control.
- Easy to maneuver, large tires and small footprint make it easy to get into tight spaces.
- Adjustable handle, allows the user to easily to position the jack under loads.

► **Technical Specifications**

Type of Pump	Low Pressure Pump		High Pressure Pump		Current Draw at Max. Internal Relief Settings (amps)	Unload Pressure (bar)	Internal Relief Pressure (bar)	Tank (l)	Valving
	Flow (l / min.)	Pressure (bar)	Flow (l / min.)	Pressure (bar)					
<b>Electric</b>	7,2	30	1,0	700	28	62 - 84,5	700	7,6	4-Way / 3-Pos. Tandem Center Manual
<b>Air</b>	5,4		0,5		NA				

► **Ordering Information**

Order Number	Description	Stroke (mm)	Retracted Height
			A (mm)
RJ100T24E	Jack, 50-220 Ton RR 610 mm Retracted, Electric	356	610
RJ100T37E	Jack, 50-220 Ton RR 940 mm Retracted, Electric	686	940
RJ100T24A	Jack, 100 Ton RR 610 mm Retracted, Air	356	610
RJ100T37A	Jack, 100 Ton RR 940 mm Retracted, Air	686	940
RJ100T24A-C*	Jack, 100 Ton RR 610 Retracted, Air with Crib Block	356	610
RJ100T24E-C*	Jack, 50-220 Ton RR 610 Retracted, Elect with Crib Block	356	610
RJ100T37A-C*	Jack, 100 Ton RR 940 Retracted, Air with Crib Block	686	940
RJ100T37E-C*	Jack, 50-220 Ton RR 940 Retracted, Elect with Crib Block	686	940
RJ100T24A-E**	Jack, 100 Ton RR 610 Retracted, Air with Extension	356	610
RJ100T24E-E**	Jack, 50-220 Ton RR 610 Retracted, Elect with Extension	356	610
RJ100T37A-E†	Jack, 100 Ton RR 940 Retracted, Air with Extension	686	940
RJ100T37E-E†	Jack, 50-220 Ton RR 940 Retracted, Electric with Extension	686	940

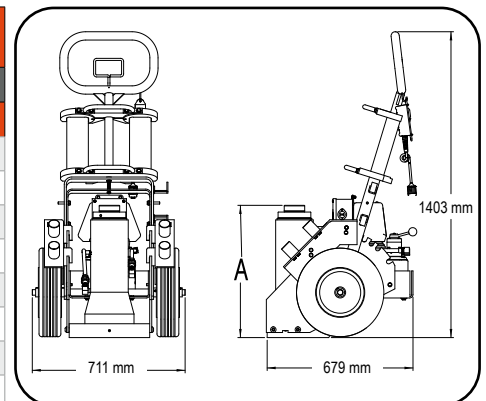

\* C models include RJ-CB-S crib set

\*\* 610 mm– E models include RJ-EXT-S1 set

† Shipping weights 940 mm– E version includes RJ-EXT-S set

**EXTENSIONS**



Order No.	Description
RJ-EXT5	Assembly, Extension 127 mm 100 Ton RR Jack
RJ-EXT7	Assembly, Extension 178 mm 100 Ton RR Jack
RJ-EXT9	Assembly, Extension 229 100 Ton RR Jack
RJ-EXT11	Assembly, Extension 279 mm 100 Ton RR Jack
RJ-EXT14	Assembly, Extension 356 mm 100 Ton RR Jack
RJ-EXT18	Assembly, Extension 457 mm 100 Ton RR Jack
RJ-EXT-S	Set, Extensions 100 Ton RR Jack 127 mm, 178 mm, 229 mm
RJ-EXT-S1	Set, Extensions 100 Ton RR Jack 127 mm, 279 mm, 457 mm

**CRIBBING BLOCKS**



Order No.	Description
RJ-CB1	Assembly, Crib Block 25 mm 100 Ton RR Jack
RJ-CB3	Assembly, Crib Block 76 mm 100 Ton RR Jack
RJ-CB5	Assembly, Crib Block 127 mm 100 Ton RR Jack
RJ-CB10	Assembly, Crib Block 254 mm 100 Ton RR Jack

**SPACERS**



Order No.	Description
RJ-SP-1	Spacer, 25 mm
RJ-SP-2	Spacer, 51 mm
RJ-SP-3	Spacer, 76 mm
RJ-SP-S	Spacer Set 100 ton RR Jack 25 mm, 51 mm, 76 mm

**SWIVEL CAPS**



Order No.	Description
RJ-SC-1	Assembly, Swivel Cap 100 Ton RR Jack

Jacks

Model Shown:

**JEM5526,PMA55S,PME55S**



Air pump and cart module

Electric pump and cart module

### Features

**PORTABLE AND COMPACT, IDEAL FOR LOCOMOTIVE/RAIL CAR, MINING AND HEAVY EQUIPMENT MAINTENANCE.**

- Modular design allows you to change lifting modules to suit your tonnage or height requirements.
- Select the collapsed height to fit your most frequent application and add jacking modules to suit your needs.
- Exclusive load control system provides positive, chatter-free control when lowering the load.
- Remote operation for maximum operator safety and control, motor or/an valve options.
- Easy to maneuver with large tires and small "footprint" make it easy to scoot into the tightest quarters.
- Adjustable, heavy-duty handle makes this jack easy to move, position under vehicles.
- Shielded and sheltered hydraulic lines for safer, longer, trouble-free service.



Jacks

### JACK MODULE EXTENSION

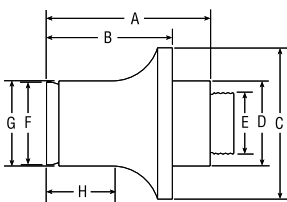

Order Number	Cap.	A	B	C	D	E	F	G	H	Prod. Wt. (kg)
	(tons)	(mm)	(mm)	(mm)	(mm)	(in.)	(mm)	(mm)	(mm)	
58945	50	223,8	173,0	127,0	66,8	1 11/18-8UNC	63,5	66,8	92,2	9,5
58943	91	228,6	177,8	174,8	98,6	2 3/4-12UNC	95,3	98,6	95,3	18,1
58944	136	219,2	168,4	203,2	114,3	3 1/4-8UNC	111,3	114,3	88,9	22,7

### Ordering Information - Cribbing Block sets - Includes one Jack Module Extension

Order Number	50 Ton CBS55		91 Ton CBS100		136 Ton CBS150		181 Ton CBS200	
No. in Set	(mm)	(mm)	(mm)	(mm)	(mm)	(mm)	(mm)	(mm)
A	381,1	76,2	38,1	76,2	38,1	76,2	38,1	76,2
B	44,4	82,5	44,4	82,5	44,4	82,5	44,4	82,5
C	139,7	139,7	139,7	139,7	222,2	222,2	254,0	254,0
Jack Module Ext.	173,0		177,8		168,3		168,3	
Total Stack Ht.	515,9		520,7		512,2		512,2	
Product Weight (kg.)	16,3		30,9		38,6		47,7	



**Pump Module, include Remote Pendant**

Pump	Motor Only	Motor & Valve
Air	PMA55	PMA55S
Electric**	PME55	PME55S



**Jack Modules**

Tonnage	Cylinder Stroke (mm)	Collapsed Height		
		660,4 mm	838,2 mm	1143,0 mm
50	333	JM25	JM35	JM45
91	333	JM210	JM310	JM410
136	461	JM215 †	JM315	JM415
181	461	JM220 *	JM320	JM420
272	333	<b>Contact Factory</b>		

\* Collapsed height; 711 mm and stroke 333 mm

\*\* Electric versions range from 50-200 tons

† Stroke 333 mm.

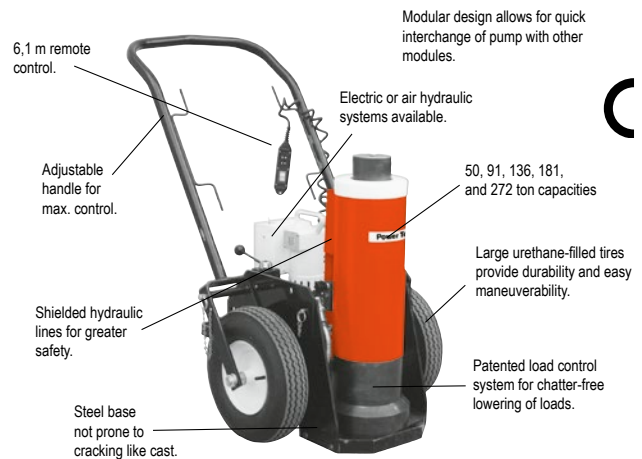

**PUMP & CART MODULES**

Pump and cart modules contain hydraulic pump, cart, remote control and all hoses and fittings required to connect to a jack module.

**JACK MODULES**

Jack modules easily separate from the pump and cart module.

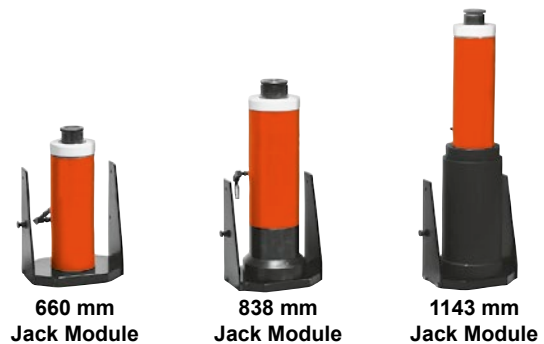
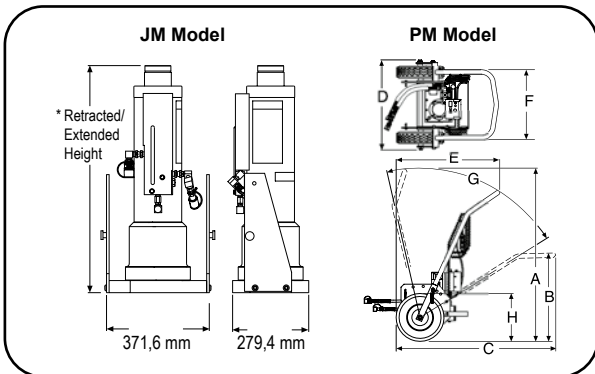

**Technical Dimensions**

Model Series	A (mm)	B (mm)	C (mm)	D (mm)	E (mm)	F (mm)	G* (deg.)	H (mm)
PMA	1464	752	1353	762	872	594	70°	406 Tire Dia.
PME								

\* Total range with varying degree increments.

**Ordering Information - Complete with Pump and Jack Modules, Fully Assembled**

Order Number	Cap. (tons)	Retracted Height (mm)	Extended Height (mm)	Stroke (mm)	Pump Type	Power Required	Valve Type	Remote Control
JEM5526	50	660,4	994	333	Electric	13/25 amps	Manual	Motor Only
JAM10033	91	838,2	1172	333	Air	1,4 cm <sup>3</sup> /min @ 6 bar	Manual	Motor Only
JAR10033	91	838,2	1172	333	Air	1,4 cm <sup>3</sup> /min @ 6 bar	Air Pilot	Motor & Valve
JEM15026	136	660,4	994	460,4	Electric	25 amps	Manual	Motor Only
JAM15033	136	838,2	1173	460,4	Air	1,4 cm <sup>3</sup> /min @ 6 bar	Manual	Motor Only

Model Shown:  
**SK10TE**



**Features**

**VERSATILE 10 TON MAINTENANCE KIT  
CONVENIENTLY PACKAGED IN A BOX.**

- 9 ton Start-Up Kit covers a range of lifting, shifting, and positioning needs
- Broad range of cylinder types and strokes to fit many applications
- Neatly packaged in a durable, molded storage case to securely house your equipment and is ready to use upon opening
- SK10TE kit is CE Compliant



**Storage Case Dimensions**



Plastic Molded Case, 800 mm (L) x 521 mm (H) x 292 mm (W).

**Ordering Information**

Kit Contents - Order no: SK10TE			
Hand Pump	Usable Oil Cap. (l)	Volume Per Stroke Low / High Press. (ml)	Weight (kg)
P19L	443	4,1 / 0,9	2,3
Gauge	Type	Primary Units	Face Diameter (mm)
9040E	analog	bar	63,5
Hose	Length (m)	Burst Rating	I.D. (mm)
9754E	1,8	4:1	6,5
Cylinders	Metric Tons	Stroke (mm)	Collapsed Height (mm)
C106C	9,1	155,6	247,7
RSS101	9,1	38,1	88,9
RH123	10,9	76,2	184,2
RLS100	10,9	11,1	44,5
Spreader	Min. Clearance (mm)	Max Spread (mm)	Weight (kg)
HS2000	14,2	101,6	2,2
Case	Material	L x H x W (mm)	Weight w/o Product (kg)
2008632	Heavy-Duty Plastic	800 x 520 x 292	5,8

Model Shown:  
**SK25T**



**NOTE:** Storage cases are not included with the 23 ton startup kits, they must be ordered separately.

**Features**

**THE RIGHT CHOICE FOR THOSE HIGHER TON MAINTENANCE KIT NEEDS.**

- 23 Ton Start-Up Kit covers a range of lifting, shifting, and positioning needs
- Broad range of cylinder types and strokes to fit many applications
- SK25TE kit is CE Compliant

**Optional 25 Ton Storage Cases**

**MB5**

**308435OR9**

Order No.	Description
<b>MB5</b>	Metal Box Construction, 813 mm (L) x 483 mm (W) x 356 mm (H)
<b>308435OR9</b>	Wooden Box Construction, 914 mm (L) x 445 mm (W) x 356 mm (H)

**Ordering Information**

Kit Contents - Order no: SK25TE			
Hand Pump	Usable Oil Cap. (l)	Volume Per Stroke Low / High Press. (l)	Weight (kg)
P59L	1082	12 / 2,6	4,1
Gauge	Type	Primary Units	Face Diameter (mm)
9040E	analog	bar	63,5
Hose	Length (m)	Burst Rating	I.D. (mm)
9754E	1,8	4:1	6,5
Cylinders	Capacity Mertic Tons	Stroke (mm)	Collapsed Height (mm)
C256C	23	158,8	273,0
RSS302	27	61,9	117,5
RH302	27	63,5	158,8
RLS300	27	12,7	58,7
Spreader	Min. Clearance (mm)	Max Spread (mm)	Weight (kg)
HS2000	14,2	101,6	2,2

Jacks

Model Shown:

**SJ2010, SJ3010**

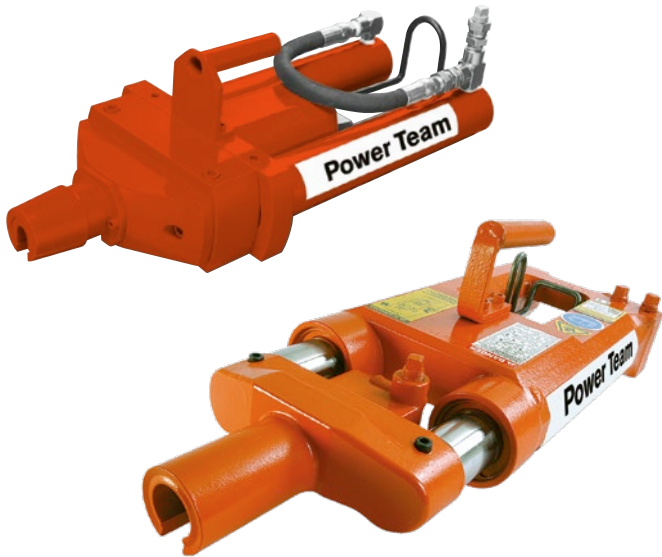

### Features

#### ONE OF THE MOST DURABLE MONO-STRAND JACKS IN THE INDUSTRY.

- Ideally suited for work on slab-on-grade where dirt, heat and high volume use take their toll.
- Available in single or double-acting models.
- Standard single-acting units have a 254 mm stroke.
- Standard double-acting units have an 152,4 mm stroke.
- Service repair is simple and components are long lasting and easily replaced.
- 76,2 mm detachable seater nose assembly easily replaced with optional 152,4 mm nose assembly.
- The jack of choice for high-rise and elevated work, thanks to fast return time and light weight.
- All hydraulic fluid controls are internal for more efficient and safer operation during tensioning and retraction.



#### Optional Dead-end Seater

Dead-end seaters for production work and field work available on special order. (Part #400120)

#### Multi-strand post-tensioning application



► **Technical Dimensions**

Order No.	A (mm)	B (mm)	C (mm)	Wt. (kg)
SJ2010	533,4	228,6	152,4	24,9
SJ2010P	558,8	259,2	177,8	34,5
SJ3010	558,8	259,2	177,8	34,5
SJ3010P	558,8	259,2	177,8	34,5
SJ2010DA	457,2	177,8	152,4	19,1
SJ3010DA	457,2	203,2	152,4	23,6

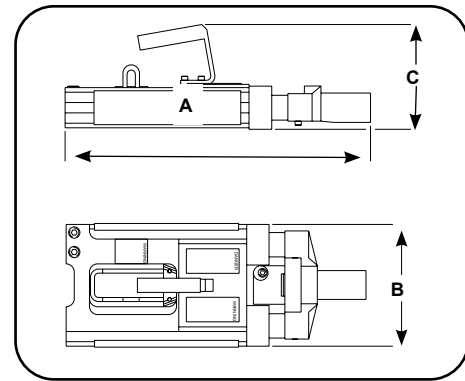

► **Ordering Information**

Order Number	Cap. (tons)	Stroke (mm)	Oil Cap. (l)	Strand Dia. (mm)	Seater Type	Int. Press. at Cap. (mm)	Metric Tons at 700 bar	Description	Recommended Pumps for this Stressing Jack	Prod. Wt. (kg)
SJ2010	18	254	0,7	11,1 - 12,7	Spring	227,3	20,3	Post-tension jack with spring, seater 12,7 mm strand.	PE554PT-E220	25
SJ2010P	18	254	0,7	11,1 - 12,7	Power	227,3	20,3	Post-tension jack with power seater, 12,7 mm strand.		25
SJ2010DA*	18	216	0,9	11,1 - 12,7	Power	192,4	23,9	Double-acting post-tension jack with power seater, 12,7 mm strand.		19
SJ3010	27	254	1,0	11,1 - 15,2	Spring	242,5	28,5	Post-tension jack with spring seater, 15,2 mm strand.		34,5
SJ3010P	27	254	1,0	11,1 - 15,2	Power	242,5	28,5	Post-tension jack with power seater, 15,2 mm strand.		34,5
SJ3010DA*	27	216	1,1	11,1 - 15,2	Power	191,87	36,0	Double-acting post-tension jack with power seater, 15,2 mm strand.		23,6

\*Options with Power Seaters require an additional hose to connect to the Power Seater to the valve.

**STRESSING JACK ACCESSORIES AND HOSES**

Used with Stressing Jack	76,2 mm Nose Piece #	76,2 mm Wedge Seater #	152,4 mm Nose Piece	152,4 mm Wedge Seater #	9,5 mm Dia. Gripper Set #	11,1 mm Dia. Gripper Set #	12,7 mm Gripper Set #	15,2 mm Gripper Set #	Replacement Gripper Handle #	Gripper Retainer Plate # (2 used)
SJ2010	252564	252562	252759	252763	252568	252761	252567	NA	252570	252565
SJ2010P	252564	252562	252759	252763	252568	252761	252567	NA	252570	252565
SJ2010DA	252543	252542	252760	252764	252650	252762	252555	NA	252556	252544
SJ3010	252564	252562	252759	252763	252568	252761	252567	252569	252570	252565
SJ3010P	252564	252562	252759	252763	252568	252761	252567	252569	252570	252565
SJ3010DA	253363	253361	253364	253362	253390	NA	253391	253365	252556	252544









# HYDRAULIC & MECHANICAL TOOLS

## SELECT FROM A WIDE RANGE OF HYDRAULIC & MECHANICAL TOOLS TO COMPLETE YOUR SYSTEM REQUIREMENTS

- Full range of torque wrenches, low clearance in-line drives and pumps for your bolting applications.
- Specialty tools include nut splitters, spreaders, bead breakers and pipe flange tools.
- Hydraulic clamps for those unique applications requiring higher forces.
- Hydraulic testers and accessories to monitor hydraulic circuits.
- Wide selection of mechanical tools, such as pliers, pry bars, O-ring picks, thread chasers and more.



Powerthon  
Limited  
**Lifetime**  
WARRANTY  
ISO 9001 Certified

Worry Free  
Ownership

	<b>Section / Series</b>	<b>Page Description</b>	<b>Page(s)</b>
	<b>TWHC, TWLC, TWSL</b>	High Cycle Torque Wrench, Low Clearance Torque Wrench, SlimLine Torque Wrench	<b>187-190 191-196 197-198</b>
	<b>FCV</b>	Flow Control Valve	<b>199</b>
	<b>NRP Series</b>	Pneumatic Torque Tools	<b>201-202</b>
	<b>PE55 TWP</b>	Electric Hydraulic Torque Wrench Pump	<b>202</b>
	<b>RWP55</b>	Air Hydraulic Torque Wrench Pump	<b>203</b>
	<b>HNS</b>	Hydraulic Nut Splitter	<b>204</b>
	<b>FLS</b>	Hydraulic Flange Spreader	<b>205-206</b>
	<b>HFS</b>	Pipe Flange, Hydraulic Spreader	<b>207</b>
	<b>HS</b>	Hydraulic Spreaders	<b>208</b>
	<b>CC</b>	Hydraulic C-Clamps & Accessories	<b>209</b>
	<b>HP35</b>	Hydraulic Punches and Accessories	<b>211-212</b>
	<b>HT</b>	Hydraulic Testers and Accessories	<b>213-215</b>
	<b>PLIERS</b>	Retaining Ring Pliers (Internal & External)	<b>216</b>
	<b>HAND TOOLS</b>	Wrenches, Pry Bars, Spanners & Jimmy Bars	<b>217</b>
	<b>SERVICE TOOLS</b>	Pipe Sealant, O-Ring Seal Picks, Thread Chaser, and Magnetic Pick-Up	<b>218</b>

Model Shown:  
**TWHC3**



▶ The TWHC50 is the perfect choice in this power generation application.



### Features

#### QUALITY MEANS LOWER COST OF OWNERSHIP

- Designed for high cycle life (2-3x more than existing technology)
- Increased reliability provided by simple drive assembly means less downtime
- Corrosion resistant material for use in harsh environments

#### ENHANCED USABILITY:

- Compact nose radius allows the tool to fit in tighter, hard-to-reach spaces
- Low weight, high strength design
- Fast operation, long stroke and optimum flow
- Multi-direction high flow swivel manifold
- Push-button square drive reversal and reaction arm positioning for all models except TWHC50

#### DESIGNED WITH SAFETY IN MIND:

- Fully-enclosed drive mechanism for operator safety
- Swivel manifold internal relief valve prevents retract side over-pressurization
- Fine tooth pawl prevents tool 'lock-on'



**HANDLES SOLD SEPARATELY**



The tool's designed long-stroke mechanism imparts a minimum 30 degree nut rotation per stroke while maintaining a tight and compact nose radius. This is a clear advantage over the short stroke and back-up pawl mechanisms of light alloy competitive models. Fewer parts and reduced torsion in operation equals reduced wear, maintenance and associated costs.

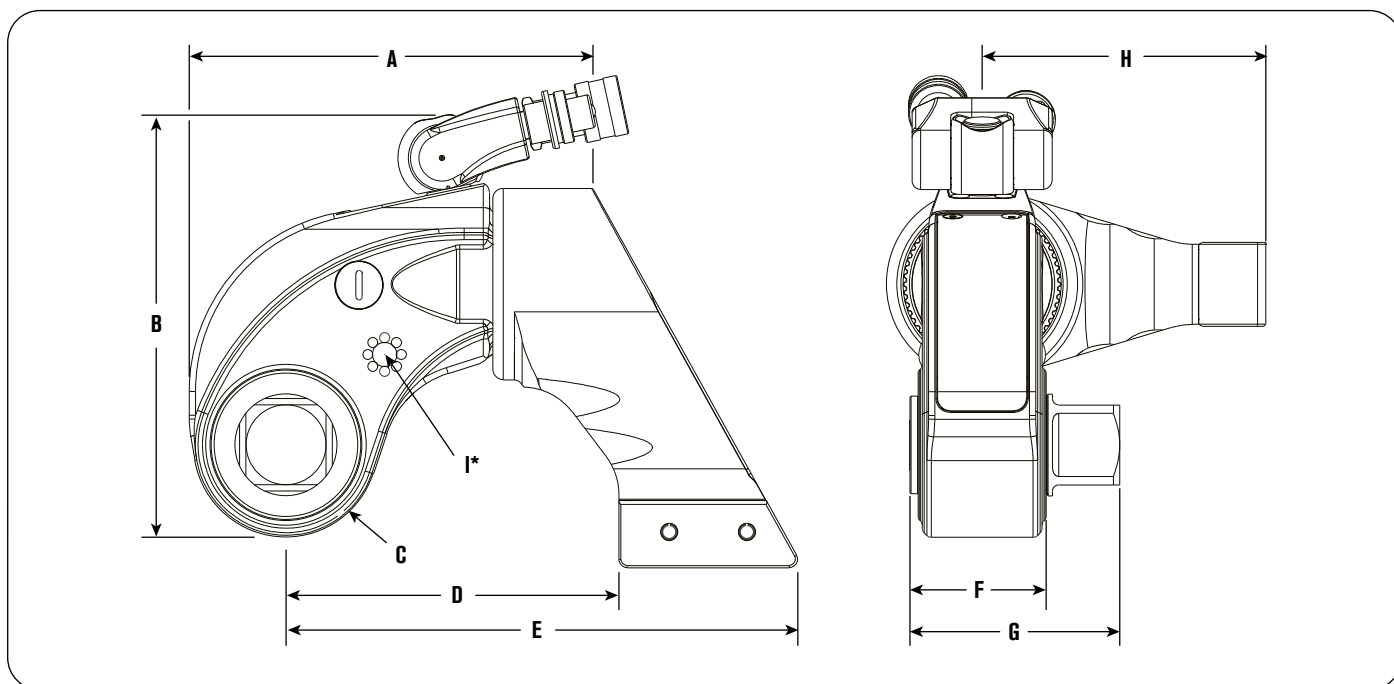

\* Dimension I shows thread size (on both sides of the tool) for safety handle or lifting point. TWHC50 model available with lifting points only.

**Technical Dimensions**

Model	Min Torque		Max Torque		Sq. Drive	A	B	C	D	E	F	G	H	I	Weight	
	lb-ft	Nm	lb-ft	Nm	In	Millimeters (Inches)										Kg
TWHC1	170	230	1413	1915	3/4	132 (5.20)	145 (5.71)	28 (1.10)	111.5 (4.39)	170.0 (6.69)	39.5 (1.56)	67.7 (2.67)	86.1 (3.39)	M6 X 1.0	2.8	6.2
TWHC3	376	510	3136	4249	1	165 (6.50)	173.5 (6.83)	36.5 (1.44)	129.6 (5.10)	197.7 (7.78)	53 (2.09)	83.7 (3.30)	105.1 (4.14)	M6 X 1.0	5.3	11.7
TWHC6	726	982	6050	8198	1½	192 (7.56)	201.6 (7.94)	44 (1.73)	158.5 (6.24)	243.7 (9.59)	61 (2.40)	99.9 (3.93)	135.1 (5.32)	M8 X 1.25	8.8	19.4
TWHC11	1336	1811	11134	15095	1½	231 (9.09)	233 (9.18)	53 (2.07)	186 (7.34)	300 (11.81)	86 (3.39)	130 (5.12)	207 (8.16)	M8 X 1.25	15.9	34.9
TWHC20	2439	3305	20325	27541	2½	280 (11.01)	310 (12.21)	64 (2.52)	220 (8.65)	364 (14.34)	94 (3.68)	155 (6.10)	212 (8.35)	M12 X 1.75	27.5	60.8
TWHC35	3890	5271	32418	43927	2½	340 (13.40)	346 (13.61)	78 (3.05)	251 (9.90)	425 (16.73)	121 (4.74)	182 (7.15)	228 (8.97)	M12 X 1.75	46.3	102
TWHC50	6360	8628	53000	71816	2½	404.5 (15.93)	356.6 (14.04)	88 (3.46)	266.5 (10.49)	446.6 (17.58)	115 (4.53)	192.2 (7.57)	258 (10.16)	M12 X 1.75	69	152

**Ordering Information**

Order No.	Description
TWHC1	Wrench
TWHC3	Wrench
TWHC6	Wrench
TWHC11	Wrench
TWHC20	Wrench
TWHC35	Wrench
TWHC50	Wrench

Order No.	Description
TWHC1H	Wrench with Handle
TWHC3H	Wrench with Handle
TWHC6H	Wrench with Handle

Order No.	Description
DFTAS000001	Handle for TWHC1
DFTAS000001	Handle for TWHC3
DFTAS000002	Handle for TWHC6
DFTAS000002	Handle for TWHC11
DFTAS000002	Handle for TWHC20
DFTAS000002	Handle for TWHC35

**TWHC EXTENDED REACTION ARM TWHC-ERA**



**Features**

- Long reach version of TWHC standard reaction arm
- 3 standard sizes per model (25 mm / 50 mm / 75 mm), specials upon request
- Replaces standard reaction arm via quick release locking pin
- Steel alloy construction
- 360° rotation
- Available for full range of tool sizes

**Ordering Information**

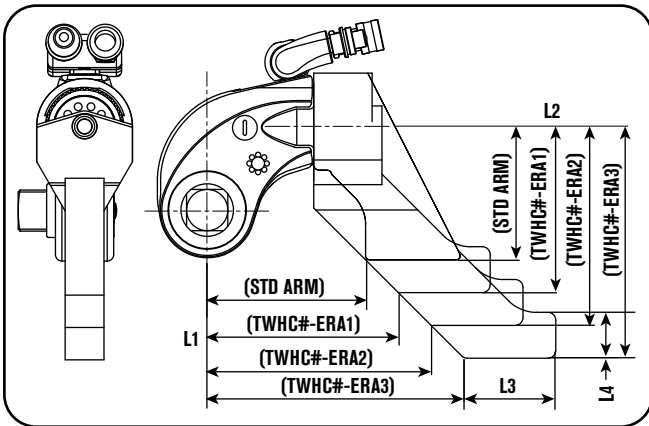

Tool Ref	Order No.	L1	L2	L3	L4	Weight (kg)
		(mm)	(mm)	(mm)	(mm)	
STD ARM		112,0	86,1	—	—	—
TWHC1	TWHC1-ERA1	136,9	111,0	59,9	30,0	2
	TWHC1-ERA2	162,1	135,9			2,3
	TWHC1-ERA3	186,9	161,0			2,6
STD ARM		130,0	104,9	—	—	—
TWHC3	TWHC3-ERA1	154,9	130,0	70,1	35,1	3
	TWHC3-ERA2	180,1	154,9			3,5
	TWHC3-ERA3	205,0	180,1			3,9
STD ARM		158,2	135,9	—	—	—
TWHC6	TWHC6-ERA1	183,9	161,0	95,0	39,9	5
	TWHC6-ERA2	209,0	185,9			5,6
	TWHC6-ERA3	233,9	211,1			6,2

**TW HANDLE**



**Features**

- Robust steel construction with ribbed polymer grip
- Multi-position on tool for balanced handling
- Cap-screw locking with positive 'docking'
- Is suitable for all wrench models (TWHC, TWLC). However, for larger sizes (TWLC30/TWHC20/35/50) we recommend the use of eye-bolt lifting.

**Ordering Information**

Order No.	Description	Tool Ref
DFTAS000001	Wrench Handle	TWHC1
		TWHC3
		TWLC2

Order No.	Description	Tool Ref
DFTAS000002	Wrench Handle	TWHC6
		TWHC11
		TWHC20
		TWHC35
		TWLC4
		TWLC8
		TWLC15

**TWHC REACTION PAD TWHC-RP**



**Features**

- In-Line Reaction Pad for TWHC wrenches used as simple pad, or modified platform for specific application (Machine-able/Weld-able platform)
- Replaces standard reaction arm via quick release locking pin
- Steel alloy construction
- 360° rotation
- Available for full range of tool sizes

**Ordering Information**

Tool Ref	Order No.	L1	L2	L3	Width (mm)	Weight (kg)
		(mm)	(mm)	(mm)		
TWHC1	TWHC1-RP	72,0	116,0	49,0	64,0	1
TWHC3	TWHC3-RP	86,1	137,9	55,1	75,9	1,5
TWHC6	TWHC6-RP	99,1	162,1	62,0	88,9	2,3

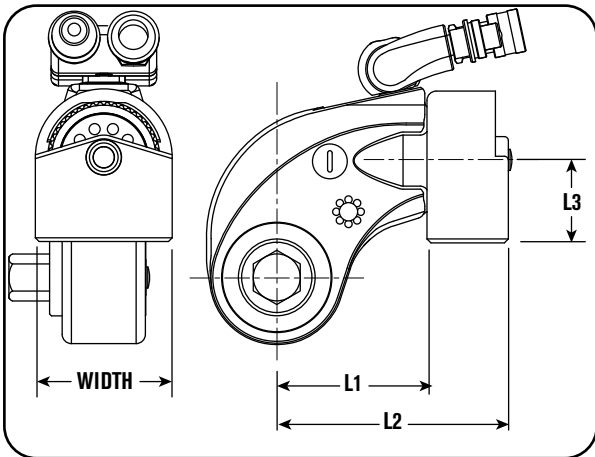

**TWHC LONG REACTION ARM TWHC-LRA**



**Features**

- Tubular extension arm for TWHC wrenches for in-line reaction outside wrench profile
- Replaces standard reaction arm via quick release pin locking
- Steel/light alloy construction (reaction flat machined on tube end)
- Can be cut down to suit specific length
- Available for full range of tool sizes

**Ordering Information**

Tool Ref	Order No.	L1	L2	Weight (kg)
		(mm)	(mm)	
TWHC1	TWHC1-LRA	500,9	152,4	4,5
TWHC3	TWHC3-LRA			6
TWHC6	TWHC6-LRA			8,1

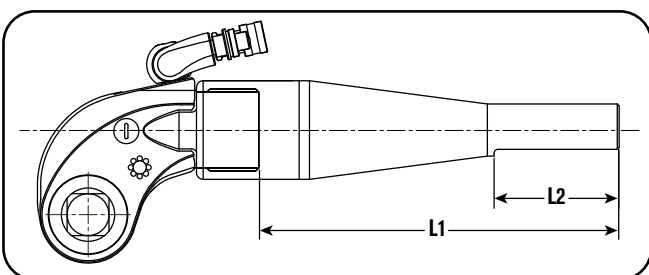

Model Shown:

**TWLC Body**



\* Links sold separately.  
Tool is not shipped with link.

**Features**

**THE CLEARANCE TOOL FEATURES A LONG NECK, SHORT HEIGHT, AND SMALL NOSE RADIUS FOR INACCESSIBLE BOLTING AREAS FOUND IN INDUSTRY.**

- Corrosion resistant finish, low weight, high strength steel body construction design with superior torsional strength.
- Fine tooth ratchet with floating piston design with small nose radius, allows for a fast operation cycle.
- Link pin does not fall out.
- Multi-axis high flow swivel manifold with internal relief valve prevents retract side over-pressurization
- “Hardened” steel reaction pad on TWLC8, 15 & 30
- Simple design, auto-connect drive piston quick interchangeable heads, no tools necessary, consistent torque output
- Replaceable reaction pad on larger models
- Power Team PowerThon™ Limited Lifetime Warranty

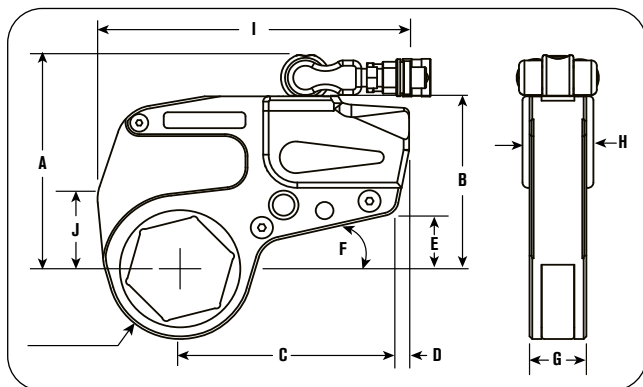

**Torque Wrench Hoses - Non-Conductive Dual Line**



Order No.	Hose Length (m)	Hose I.D. (in.)
TWH15E	4,6	1/4"
TWH20E	6,1	1/4"
TWH30E	15,2	1/4"

**Technical Dimensions**

Body Order No.	A (mm)	B (mm)	C (mm)	D (mm)	E (mm)	F (mm)	G (mm)	H (mm)
TWLC2	96,5	104,1	127,0	7,6	35,6	12,7	33,0	43,2
TWLC4	119,4	129,5	160,0	10,2	43,2	12,7	43,2	50,8
TWLC8	147,3	157,5	177,8	25,4	40,6	15,2	53,3	66,0
TWLC15	175,3	185,4	200,7	27,9	43,2	15,2	63,5	76,2
TWLC30	223,5	238,8	266,7	25,4	61,0	15,2	81,3	94,0

**Ordering Information**

Tool Model	Hex Range (mm)	Min.Torque (Nm)	Max.Torque (Nm)	Weight. (Body Only) (kg)
TWLC2	26 - 50	256	2135	1,0
TWLC4	33 - 80	647	5389	2,0
TWLC8	49 - 100	1293	10779	3,5
TWLC15	62 - 116	2416	20134	7,0
TWLC30	80 - 115	4686	39048	14,5



**Special sizes available upon request.**

**LOW CLEARANCE - REDUCERS**

Body Order No.	Link	Nut A/F (mm)	Reducer (mm)	Reducer	Reducer (mm)	Reducer	Reducer (mm)	Reducer
	Part No.			Part No.		Part No.		Part No.
TWLC2	TWL2-032	32	—	—	—	—	—	—
	TWL2-036	36	—	—	—	—	—	—
	TWL2-041	41	41-36	TWR2-041036	41-32	TWR2-041032	—	—
	TWL2-046	46	46-41	TWR2-046041	46-36	TWR2-046036	46-32	TWR2-046032
	TWL2-050	50	50-46	TWR2-050046	50-41	TWR2-050041	50-36	TWR2-050036
	TWL2-055	55	55-50	TWR2-055050	55-46	TWR2-055046	55-41	TWR2-055041
TWLC4	TWL4-060	60	60-55	TWR2-060055	60-50	TWR2-060050	60-46	TWR2-060046
	TWL4-041	41	41-36	TWR4-041036	41-32	TWR4-041032	—	—
	TWL4-046	46	46-41	TWR4-046041	46-36	TWR4-046036	46-32	TWR4-046032
	TWL4-050	50	50-46	TWR4-050046	50-41	TWR4-050041	50-36	TWR4-050036
	TWL4-055	55	55-50	TWR4-055050	55-46	TWR4-055046	55-41	TWR4-055041
	TWL4-060	60	60-55	TWR4-060055	60-50	TWR4-060050	60-46	TWR4-060046
	TWL4-065	65	65-60	TWR4-065060	65-55	TWR4-065055	65-50	TWR4-065050
	TWL4-070	70	70-65	TWR4-070065	70-60	TWR4-070060	70-55	TWR4-070055
TWLC8	TWL4-075	75	75-70	TWR4-075070	75-65	TWR4-075065	75-60	TWR4-075060
	TWL4-080	80	80-75	TWR4-080075	80-70	TWR4-080070	80-65	TWR4-080065
	TWL8-060	60	60-55	TWR8-060055	60-50	TWR8-060050	60-46	TWR8-060046
	TWL8-065	65	65-60	TWR8-065060	65-55	TWR8-065055	65-50	TWR8-065050
	TWL8-070	70	70-65	TWR8-070065	70-60	TWR8-070060	70-55	TWR8-070055
	TWL8-075	75	75-70	TWR8-075070	75-65	TWR8-075065	75-60	TWR8-075060
	TWL8-080	80	80-75	TWR8-080075	80-70	TWR8-080070	80-65	TWR8-080065
	TWL8-085	85	85-70	TWR8-085080	85-65	TWR8-085075	85-70	TWR8-085070
TWLC15	TWL8-090	90	90-85	TWR8-090085	90-80	TWR8-090080	90-75	TWR8-090075
	TWL8-095	95	95-90	TWR8-095090	95-85	TWR8-095085	95-80	TWR8-095080
	TWL8-100	100	100-95	TWR8-100095	100-90	TWR8-100090	100-85	TWR8-100085
	TWL15-070	70	70-65	TWR15-070065	70-60	TWR15-070060	70-55	TWR15-070055
	TWL15-075	75	75-70	TWR15-075070	75-65	TWR15-075065	75-60	TWR15-075060
	TWL15-080	80	80-75	TWR15-080075	80-70	TWR15-080070	80-65	TWR15-080065
	TWL15-085	85	85-80	TWR15-085080	85-75	TWR15-085075	85-70	TWR15-085070
	TWL15-090	90	90-85	TWR15-090085	90-80	TWR15-090080	90-75	TWR15-090075
	TWL15-095	95	95-90	TWR15-095090	95-85	TWR15-095085	95-80	TWR15-095080
	TWL15-100	100	100-95	TWR15-100095	100-90	TWR15-100090	100-85	TWR15-100085
TWLC30	TWL15-105	105	105-100	—	105-95	—	105-90	—
	TWL15-425	—	—	TWR15-425388	—	TWR15-425375	—	TWR15-425350
	TWL15-110	110	110-105	—	110-100	—	110-95	—
	TWL15-115	115	115-110	—	115-105	—	115-100	—
	TWL15-463	—	—	TWR15-463425	—	TWR15-463388	—	TWR15-463375
	TWL30-080	80	80-75	TWR30-080075	80-70	TWR30-080070	80-65	TWR30-080065
	TWL30-085	85	85-80	TWR30-085080	85-65	TWR30-085075	85-70	TWR30-085070
	TWL30-090	90	90-85	TWR30-090085	90-80	TWR30-090080	90-75	TWR30-090075
	TWL30-095	95	95-90	TWR30-095090	95-85	TWR30-095085	95-80	TWR30-095080
	TWL30-100	100	100-95	TWR30-100095	100-90	TWR30-100090	100-85	TWR30-100085
	TWL30-105	105	105-100	TWR30-105100	105-95	TWR30-105095	105-90	TWR30-105090
	TWL30-425	—	—	TWR30-425388	—	TWR30-425375	—	TWR30-425350
	TWL30-110	110	110-105	—	110-100	—	110-95	—
	TWL30-115	115	115-110	—	115-105	—	115-100	—
TWL30-463	—	—	TWR30-463425	—	TWR30-463388	—	TWR30-463375	
TWL30-120	120	120-115	—	120-110	—	120-105	—	
TWL30-500	—	—	TWR30-500463	—	TWR30-500425	—	TWR30-500388	
TWL30-130	130	130-120	—	130-115	—	130-110	—	
TWL30-135	135	135-125	TWR30-135125	135-120	TWR30-135120	135-115	TWR30-135115	
TWL30-145	145	—	—	—	—	—	—	
TWL30-150	150	—	—	—	—	—	—	
TWL30-155	155	—	—	—	—	—	—	

AVAILABLE UPON REQUEST

Tools

Nut A/F (mm)	TWLC2					TWLC4					TWLC8																
	Link Order No.	Radius R (mm)	I (mm)	J (mm)	Weight (Link Only) (kg)	Link Order No.	Radius R (mm)	I (mm)	J (mm)	Weight (Link Only) (kg)	Link Order No.	Radius R (mm)	I (mm)	J (mm)	Weight (Link Only) (kg)												
26	TWL2-026	31,5	180,1	38,1	2	-	36,6	227,1	53,1	224,0	-	50,5	274,1	77,0	7												
27	TWL2-027					-																					
29	TWL2-029					-																					
30	TWL2-030					-																					
32	TWL2-032					-																					
33	TWL2-033					-																					
35	TWL2-035	-	-	-	-	-	-	-	-	-	-	-	-	-	-												
36	TWL2-036	-	-	-	-	-	-	-	-	-	-	-	-	-	-												
38	TWL2-150	34,5	181,1	39,9	2	TWL4-150	36,6	227,1	53,1	224,0	-	50,5	274,1	77,0	7												
40	TWL2-040					TWL4-040					-					-	-	-	-	-	-	-	-	-	-	-	-
41	TWL2-041	-	-	-	-	TWL4-041	-	-	-	-	-	-	-	-	-												
43	TWL2-043	37,1	182,9	39,9	2	TWL4-043	39,1	227,1	53,1	4	-	50,5	274,1	77,0	7,5												
44	TWL2-044					TWL4-044					-					-	-	-	-	-	-	-	-	-	-	-	-
46	TWL2-046	-	-	-	-	TWL4-046	-	-	-	-	-	-	-	-	-												
48	TWL2-188	39,9	184,9	42,9	2	TWL4-188	41,9	227,1	53,1	4	TWL8-188	50,5	274,1	77,0	7,5												
49	TWL2-049					TWL4-049					-					-	-	-	-	-	-	TWL8-049	-	-	-	-	-
50	TWL2-050					TWL4-050					-					-	-	-	-	-	-	TWL8-050	-	-	-	-	-
52	TWL2-052	42,4	184,9	42,9	2	TWL4-052	44,5	227,1	53,1	4	TWL8-052	50,5	274,1	77,0	7												
54	TWL2-054					TWL4-054					-					-	-	-	-	-	-	TWL8-054	-	-	-	-	-
55	TWL2-055					TWL4-055					-					-	-	-	-	-	-	TWL8-055	-	-	-	-	-
57	TWL2-057	45,5	184,91	42,9	2	TWL4-225	47,5	227,1	53,1	4	TWL8-057	50,5	274,1	77,0	7,5												
59	TWL2-059					TWL4-059					-					-	-	-	-	-	-	TWL8-059	-	-	-	-	-
60	TWL2-060	-	-	-	-	TWL4-060	-	-	-	-	TWL8-060	-	-	-	-												
62	-	-	-	-	-	TWL4-062	50,0	227,1	53,1	4	TWL8-062	50,5	274,1	77,0	7,5												
63	-	-	-	-	-	TWL4-063					-					-	-	-	TWL8-063	-	-	-	-				
65	-	-	-	-	-	TWL4-065	-	-	-	-	TWL8-065	-	-	-	-												
67	-	-	-	-	-	TWL4-067	53,1	229,11	55,9	4	TWL8-067	50,5	274,1	77,0	7,5												
68	-	-	-	-	-	TWL4-068					-					-	-	-	TWL8-068	-	-	-	-				
70	-	-	-	-	-	TWL4-070	-	-	-	-	TWL8-070	-	-	-	-												
71	-	-	-	-	-	TWL4-071	55,63	229,11	55,9	4,5	TWL8-071	50,5	274,1	77,0	7,5												
73	-	-	-	-	-	TWL4-073					-					-	-	-	TWL8-073	-	-	-	-				
75	-	-	-	-	-	TWL4-075	-	-	-	-	TWL8-075	-	-	-	-												
77	-	-	-	-	-	TWL4-077	58,93	230,12	57,91	4,5	TWL8-077	50,5	274,1	77,0	7,5												
78	-	-	-	-	-	TWL4-313					-					-	-	-	TWL8-313	-	-	-	-				
80	-	-	-	-	-	TWL4-080	-	-	-	-	TWL8-080	-	-	-	-												
81	-	-	-	-	-	-	-	-	-	-	TWL8-081	67,1	277,11	71,9	8												
83	-	-	-	-	-	-	-	-	-	-	TWL8-083					-	-	-	-								
84	-	-	-	-	-	-	-	-	-	-	TWL8-084					-	-	-	-								
85	-	-	-	-	-	-	-	-	-	-	TWL8-085					-	-	-	-								
87	-	-	-	-	-	-	-	-	-	-	TWL8-087					-	-	-	-								
89	-	-	-	-	-	-	-	-	-	-	TWL8-089					-	-	-	-								
90	-	-	-	-	-	-	-	-	-	-	TWL8-090	73,41	277,11	71,88	8												
91	-	-	-	-	-	-	-	-	-	-	TWL8-091					-	-	-	-								
92	-	-	-	-	-	-	-	-	-	-	TWL8-092					-	-	-	-								
94	-	-	-	-	-	-	-	-	-	-	TWL8-094					-	-	-	-								
95	-	-	-	-	-	-	-	-	-	-	TWL8-095					-	-	-	-								
97	-	-	-	-	-	-	-	-	-	-	TWL8-097					-	-	-	-								
99	-	-	-	-	-	-	-	-	-	-	TWL8-388	-	-	-	-												
100	-	-	-	-	-	-	-	-	-	-	TWL8-100	-	-	-	-												

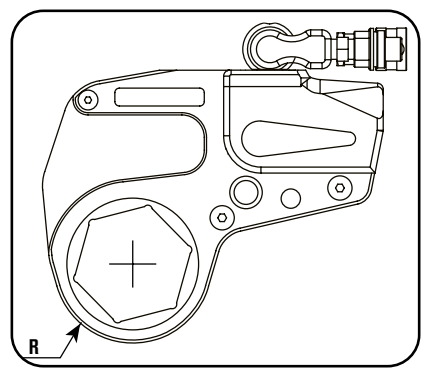

**NOTE:** The sizes listed on these pages encompass both heavy hex and standard hex nut sizes. Check your local Hydraulic Technologies Power Team Office for availability as some items may be special order.

Nut A/F (mm)	TWLC15					TWLC30					Nut A/F (mm)	TWLC30 (Continued)											
	Link Order No.	Radius R (mm)	I (mm)	J (mm)	Weight (Link Only) (kg)	Link Order No.	Radius R (mm)	I (mm)	J (mm)	Weight (Link Only) (kg)		Link Order No.	Radius R (mm)	I (mm)	J (mm)	Weight (Link Only) (kg)							
62	TWL15-062					-					122	TWL30-122											
63	TWL15-063					-					123	TWL30-123											
65	TWL15-065	60,5	312,9	87,9	12,5	-					124	TWL30-124	99,1	400,1	109,0	28,5							
67	TWL15-067					-				125	TWL30-125												
68	TWL15-068					-				127	TWL30-500												
70	TWL15-070					-				129	TWL30-129												
71	TWL15-071					-				130	TWL30-130												
73	TWL15-073	63,0	312,9	87,9	12,5	-					132	TWL30-132	104,9	400,1	109,0	28,5							
75	TWL15-075					-				133	TWL30-133												
77	TWL15-077					-				135	TWL30-135												
78	TWL15-313	66,5	312,9	87,9	13	-					137	TWL30-538					110,0	400,1	109,0	28,5			
80	TWL15-080					TWL30-080				138	TWL30-138												
81	TWL15-081					TWL30-081				140	TWL30-140												
83	TWL15-083					TWL30-083				141	TWL30-141												
84	TWL15-084					TWL30-084				143	TWL30-143												
85	TWL15-085					71,9	312,9	87,9	13,5	TWL30-085	77,0	392,9	103,9	26,5	144	TWL30-144							
87	TWL15-087									TWL30-087													
89	TWL15-089									TWL30-089													
90	TWL15-090									TWL30-090													
91	TWL15-091									TWL30-091												146	TWL30-146
92	TWL15-092	TWL30-092								148					TWL30-148								
94	TWL15-094	TWL30-094				149	TWL30-149																
95	TWL15-095	78,0	316,0	80,0	13,5	TWL30-095	83,1	392,9	103,9	26,5	150	TWL30-150											
97	TWL15-097					TWL30-097																	
99	TWL15-388					TWL30-388																	
100	TWL15-100					TWL30-100																	
102	TWL15-102					TWL30-102								151	TWL30-151								
103	TWL15-103	TWL30-103				152	TWL30-152																
105	TWL15-105	82,6	316,0	80,0	14	TWL30-105	88,9	392,9	103,9	27,5	154	TWL30-154											
106	TWL15-106					TWL30-106																	
108	TWL15-425					TWL30-425																	
110	TWL15-110	TWL30-110				155	TWL30-155																
111	TWL15-111	TWL30-111																					
113	TWL15-113	TWL30-113																					
114	TWL15-114	87,4	316,0	80,0	14	TWL30-114	91,9	392,9	103,9	27,5													
115	TWL15-115					TWL30-115																	
116	TWL15-116					TWL30-116																	
117	TWL15-463					TWL30-463																	
119	-					TWL30-119								99,1	400,1	109,0	28,5						
120	-					TWL30-120																	

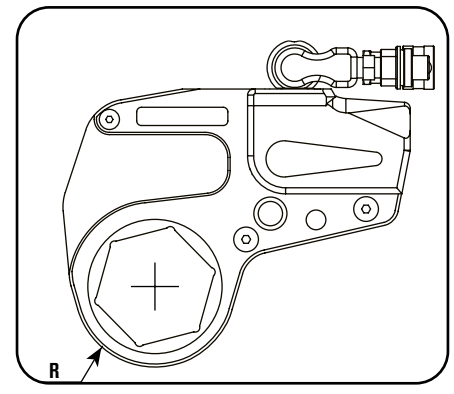

Tools

- To Specify a TWLC solution:
1. Find a link for your application (nut size)
  2. Choose the appropriate drive body
  3. Add reducers for additional nut sizes

**NOTE:** Please order Drive Body and Link separately and pay attention to the same size, for Example TWLC2 and TWL2-041.

**TWLC REACTION BAR TWLC-RB**

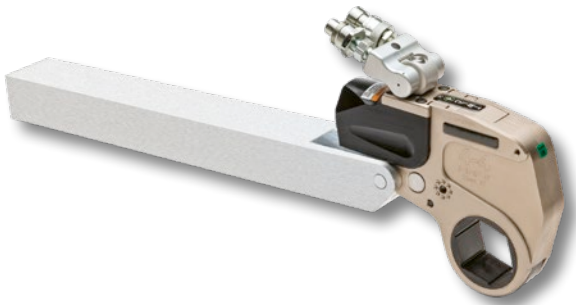

**Features**

- In-Line Extension Reaction Bar for TWLC wrenches allows extended reach on the same plane
- Pin engagement, no tools required
- Available for full range of tool sizes



**Reaction Accessories**

Power Team offers a varied range of alternative and optional reaction accessories which help to find a reaction point solution no matter how unusual the bolted application is.

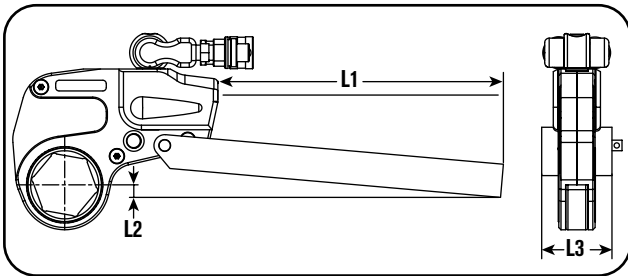

**Ordering Information**

Tool Ref	Order No.	L1 (mm)	L2 (mm)	L3 (mm)	Weight (kg)
TWLC2	TWLC2-RB	381,0	27,9	55,1	2,6
TWLC4	TWLC4-RB	457,2	35,1	66,0	4,8
TWLC8	TWLC8-RB	457,2	37,1	85,1	9,0
TWLC15	TWLC15-RB	508,0	40,0	102,0	14,5
TWLC30	TWLC30-RB	508,0	35,0	127,0	27,0

**TWLC REACTION PADDLE TWLC-RP**



**Features**

- Off-Set Reaction Arm for TWLC wrenches allows off-set reaction within wrench profile
- Pin engagement, no tools required
- Light alloy construction
- Available for full range of tool

**Ordering Information**

Tool Ref	Order No.	L1 (mm)	L2 (mm)	L3 (mm)	L4 (mm)	Weight (kg)
TWLC2	TWLC2-RP	84,1	35,1	142,0	13,0	0,5
TWLC4	TWLC4-RP	109,0	46,0	178,1	19,1	0,9
TWLC8	TWLC8-RP	136,4	57,2	220,0	25,9	1,8
TWLC15	TWLC15-RP	165,1	70,1	252,0	45,0	3,5
TWLC30	TWLC30-RP	200,0	86,1	317,0	43,9	6,0

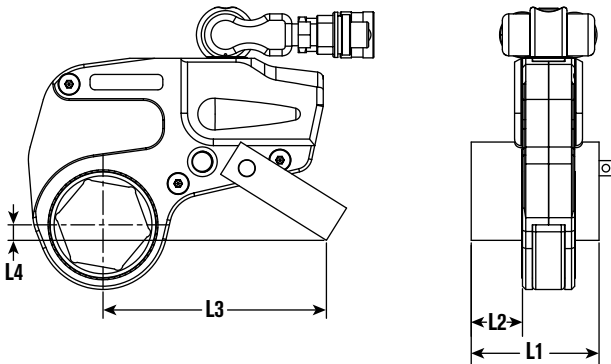

**HAVE A UNIQUE APPLICATION?  
DOES STANDARD PRODUCT NOT FIT?**



**CUSTOM REACTION PADS AND REDUCERS ARE AVAILABLE.**  
Contact Hydraulic Technologies or an authorized Power Team distributor for more details!

**WHEN NOTHING ELSE WILL WORK,  
SPLIT ADAPTERS ARE MADE TO ORDER  
AND AVAILABLE UPON REQUEST.**



TWLC15 split adapter,  
closed position



TWLC15 split adapter,  
open position

Model Shown:

**TWSL4-046 Link (left) & TWSL4-060 Link with TWLC4 Drive Body (right)**



**Features**

**ENGINEERED TO FIT INACCESSIBLE APPLICATIONS WITH MINIMAL CLEARANCE.**

- Dynamic engineering modeling (Finite Element Analysis and optimized tool design to extend life and durability).
- The SlimLine links use the same quick change Drive Body as the existing TWLC links
- Small nose radius, fits all standard API and ANSI flanges.
- Rigid steel body construction with corrosion resistant plating.
- Fully-enclosed drive mechanism for operator safety.
- Swivel manifold has an internal relief valve to prevent retract side over-pressurization.
- Multi-axis swivel technology for free positioning of tool and hoses.



**Other Related Items**

Contact your nearest Power Team sales representative for assistance in sizing the proper tool for your application, or go to [powerteam.com](http://powerteam.com) website for details about other available link sizes not listed.



**Pumps**



**Hoses**



**Tools**



**Drive Body interchanges with the TWLC & TWSL link sizes**

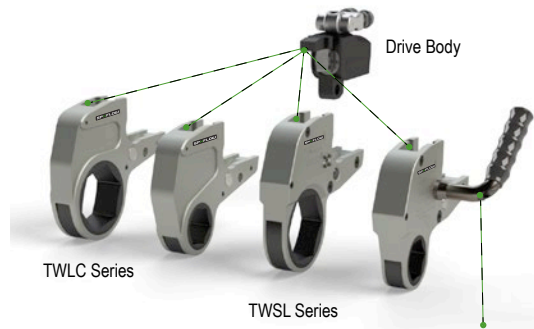

Optional Handle  
Order #: DFTAS000001 for TWSL2  
Order #: DFTAS000002 for TWSL4

The Drive Body is designed to interchange with the TWLC (Low Clearance) and the new TWSL (SlimLine) Links, lowering your tool investment across each series to broaden your application reach.

Tools

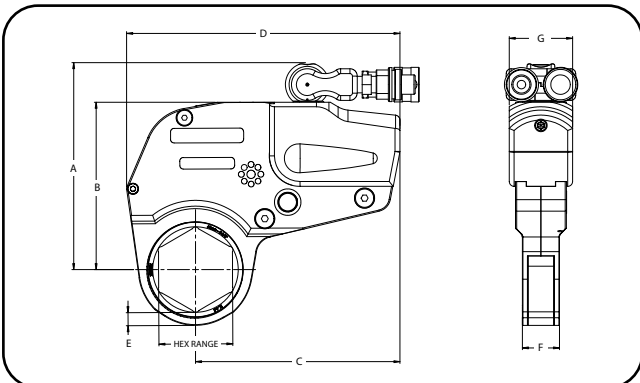

**Technical Dimensions**

Order No.	A (mm)	B (mm)	C (mm)	D (mm)	E (mm)	F (mm)	G (mm)
TWSL2	145,03	114,04	128,01	184,40	8,89	24,89	41,91
TWSL4	167,9	136,9	167,9	224,3	10,7	30,5	51,8

► **Technical Fit Overview**

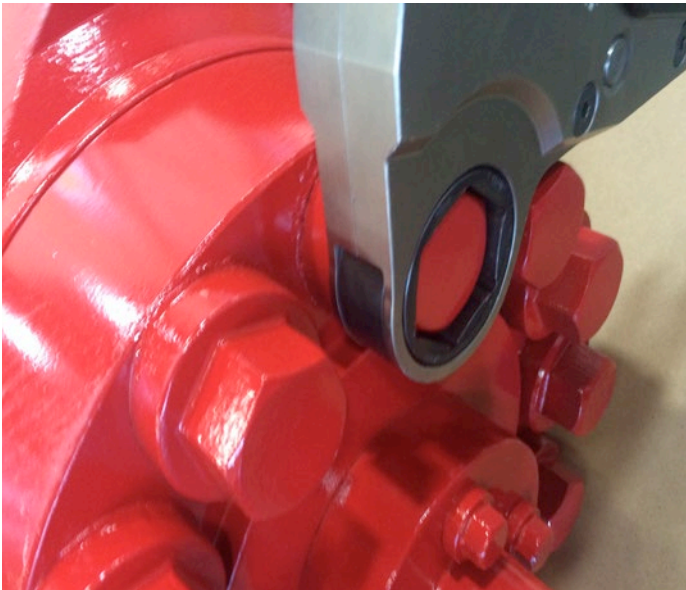

**SlimLine Application Range**

Due to the compact design, the maximum torque of the TWSL links vary depending on link size, reference the information below for complete details.

New SlimLine\* (TWSL Series)      Standard (TWLC Series)

\*Shown with optional handle, order # DFTAS000002.

► The TWSL's narrow width and reduced radius design enables the tool to fit into tight areas where standard low clearance links cannot.

► **Torque Wrench Drive Body Ordering Information for SlimLine**

Drive Body Order No.	Hex Range for SlimLine		SlimLine Min. Torque (Nm)	SlimLine Max. Torque (Nm)	Weight (Link Only) (kg)
	(mm)	(mm)			
TWLC2	28,7	60,5	Contact Factory for Details		1,0
TWLC4	46,0	79,5	685	3577 - 5707	2,0
TWLC8	57,2	100,1	Contact Factory for Details		3,5

Note: Links are sold separately from the drive body, refer to the tables below.

► **Torque Wrench Link Ordering Information for SlimLine**

Link Order No.	Hex Range for SlimLine		SlimLine Min. Torque (Nm)	SlimLine Max. Torque (Nm)	Weight (Link Only) (kg)
	(mm)	(mm)			
TWSL2-#	28,7	60,5	Contact Factory for Details		
TWSL4-#	46,0	79,5	685	3577 - 5707	3,6 - 3,8

Note: The "#" suffix will be replaced with the actual link size in a numeric value.

► **TWSL2 SlimLine Link Reference Table\***

Nut A/F (mm)	Link Order No.	Max. Torque (Nm)	Weight (Link Only) (kg)
31,75	TWSL2-032	1681	1,8
36,57	TWSL2-036	1938	1,9
41,40	TWSL2-041	2169	1,95
45,97	TWSL2-046	2508	1,95
50,8	TWSL2-050	2508	1,95
55,62	TWSL2-055	2508	1,99
60,45	TWSL2-060	2508	1,99

► **TWSL4 SlimLine Link Reference Table\***

Nut A/F (mm)	Link Order No.	Max. Torque (Nm)	Weight (Link Only) (kg)
46,0	TWSL4-046	3577	3,6
50,8	TWSL4-050	4434	3,7
55,6	TWSL4-055	4837	3,7
60,5	TWSL4-060	5242	3,8
65,0	TWSL4-065	5708	3,8
69,9	TWSL4-070	5708	3,8
74,7	TWSL4-075	5708	3,8
79,5	TWSL4-080	5708	3,8

Model Shown:  
**4000148**



### Features

- Pressure balanced spool mechanism allowing for easier trigger pull/squeeze effort (fatigue reduction)
- Two-stage trigger system (interlock and trigger) preventing accidental operation/advancement of the tool
- 2:1 Safety Factor pressure test min 1379 bar
- Can be used with any hydraulic torque wrench

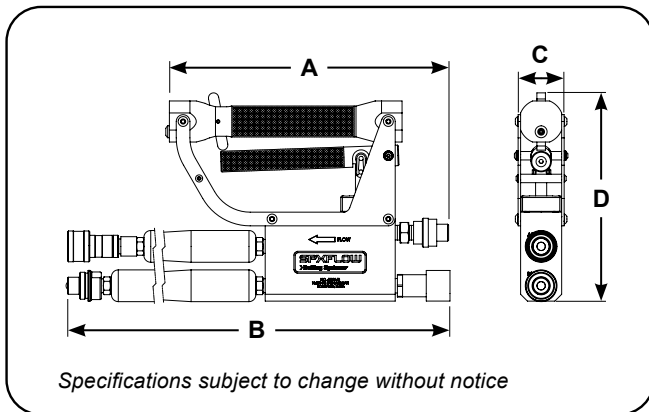

Tools

### Ordering Information

Order No.	A (mm)	B (mm)	C (mm)	D (mm)	Prod. Wt. (mm)
4000148	263,70	781,05	47,82	193,26	2,80

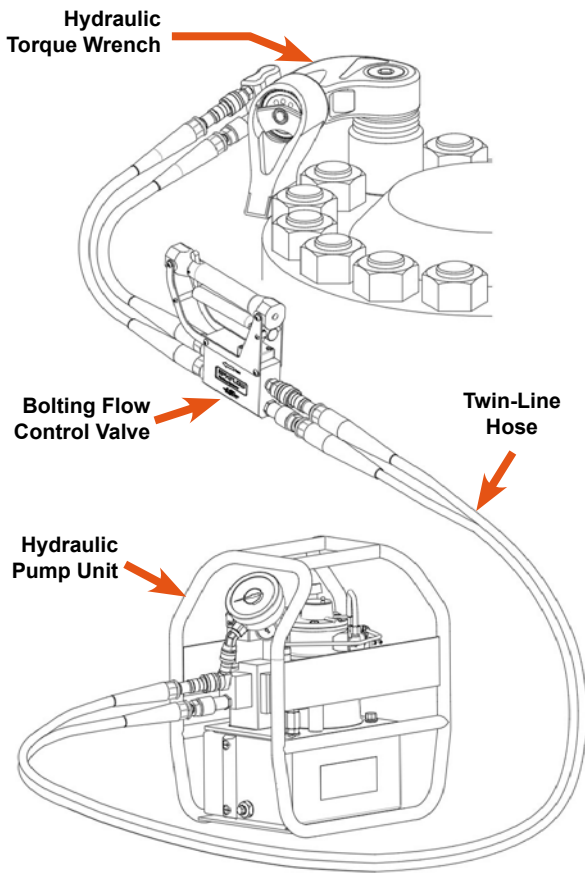

**Features**

**BOLTING FLOW CONTROL VALVE**

- ▶ Allows the operator to position the torque wrench with zero risk of entrapment or nipped fingers
- ▶ Suitable for hydraulic tool applications where local isolation and operator control is required
- ▶ Isolates the wrench whilst operator carries out drive direction changes, link switch over on low profile tools

**Other Related Items**



Pumps



Wrenches



Hoses

Refer to the Bolting Systems catalog or website for more details.

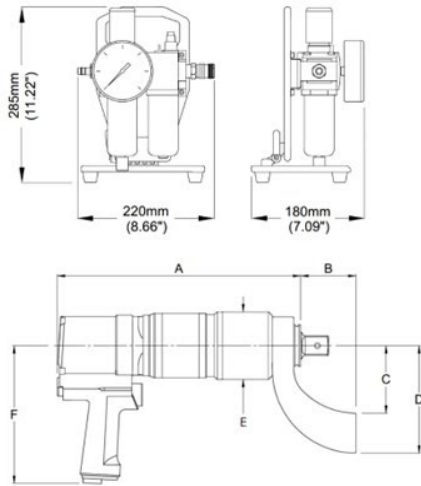

**Features**

**QUALITY MEANS HIGHER PRODUCTIVITY**

- High-speed continuous rotation, speeds up bolt working times
- Torque output accurate to +/- 3%.
- Unique calibration for each tool, with certificate.
- Stepless torque adjustment via air control unit, large easy read air pressure gauge

**DESIGNED WITH SAFETY IN MIND**

- Quiet operation for greater operator comfort.
- Robust, non-impact, low vibration gearbox design
- Pistol grip design for easy handling

**ENHANCED USABILITY**

- High-low gear, two-speed design for rapid nut rundown.
- Easy access motor switch to change drive direction
- 360 Degree rotating drive unit for easy reaction arm positioning
- Automatic switch-off at desired torque

**Technical Dimensions**

Tool Model	Min. Torque		Max. Torque		Square Drive (mm)	Rotation Speed RPM	A	B	C	D	E	F	Wt.	
	Nm	lb-feet	Nm	lb-feet									Kg	Lbs
NRP-9	60	44	900	664	19,05	40	317 (12.48)	72 (2.83)	88 (3.46)	140 (5.51)	88 (3.46)	180 (7.09)	7.4	16
NRP-15	100	74	1500	1107	19,05	28	317 (12.48)	72 (2.83)	88 (3.46)	140 (5.51)	88 (3.46)	180 (7.09)	7.4	16
NRP-30	190	140	3000	2214	25,4	13	351 (13.82)	72 (2.83)	88 (3.46)	140 (5.51)	88 (3.46)	180 (7.09)	8.5	19
NRP-45	300	221	4500	3321	31,75	9	362 (14.25)	9.2 (3.62)	105 (4.13)	175 (6.89)	102 (4.02)	180 (7.09)	11.2	25
NRP-60	480	354	6000	4428	38,1	6	317 (12.48)	9.2 (3.62)	105 (4.13)	175 (6.89)	102 (4.02)	180 (7.09)	11.2	25

\*Maximum Working Air Pressure 6.3Bar (90psi)  
\*\* Weight not including Reaction Arm

- ▶ Each kit consists of Pneumatic Torque Wrench, Air Control Unit (NRP-CU), 4m Air Hose (AH4M), Storage Case (2010883), Calibration Certificate, Operating Manual/Parts List



**Ordering Information**

Order No.	Description
NRP-9K	NRP-9K Pneumatic Torque Wrench Kit
NRP-15K	NRP-15K Pneumatic Torque Wrench Kit
NRP-30K	NRP-30K Pneumatic Torque Wrench Kit
NRP-45K	NRP-45K Pneumatic Torque Wrench Kit
NRP-60K	NRP-60K Pneumatic Torque Wrench Kit

Model Shown:

**PE55TWP, PE55TWP-4**



**Features**

**VANGUARD® ELECTRIC HYDRAULIC TORQUE WRENCH PUMPS.**

- Two-speed high-performance pump.
- External adjustable pressure regulator
- Retract side internal relief valve protects tool.
- Hand remote control with 6,1 m. cord.
- Use for single or double-acting tools.
- Four-tool manifold allows use of up to four tools simultaneously.

**CAUTION**

**THIS PUMP SHOULD NOT BE USED FOR LIFTING APPLICATIONS, IT'S DESIGN FOR TORQUE WRENCH APPLICATIONS ONLY.**

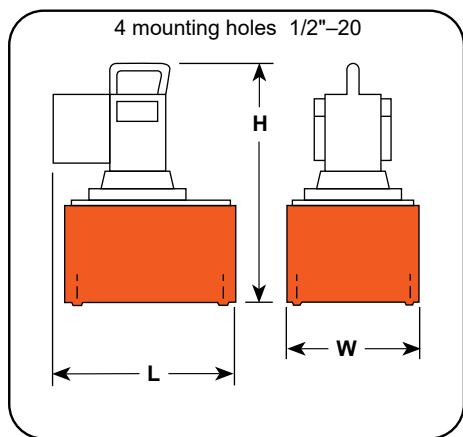

**Ordering Information**

Order No.	Width (mm)	Length (mm)	Height (mm)	Electric Motor (12000 rpm)	Oil Delivery (l/min.)	Oil Reservoir Cap. (l)	Usable Oil (l)	Prod. Wt. (kg)
PE55TWP	435	241	460	0,84 Kw		9,5	8,4	34,0
PE55TWP-E110*	470	241	460	110V / 50Hz, 25 amps	11,5 @ 7 bar 0,9 @ 700 Bar	9,5	8,4	34,0
PE55TWP-E220*	470	241	460	220V / 50Hz, 13 amps		9,5	8,4	34,0
PE55TWP-4	470	241	486	0,84 Kw		9,5	8,4	35,4
PE55TWP-4-E110*	470	241	486	110V / 50Hz, 25 amps	11,5 @ 7 bar 0,9 @ 700 Bar	9,5	8,4	35,4
PE55TWP-4-E220*	470	241	486	220V / 50Hz, 13 amps		9,5	8,4	35,4

\* CE Approved - designed for 50 Hz applications

Model Shown:  
**RWP55-4**

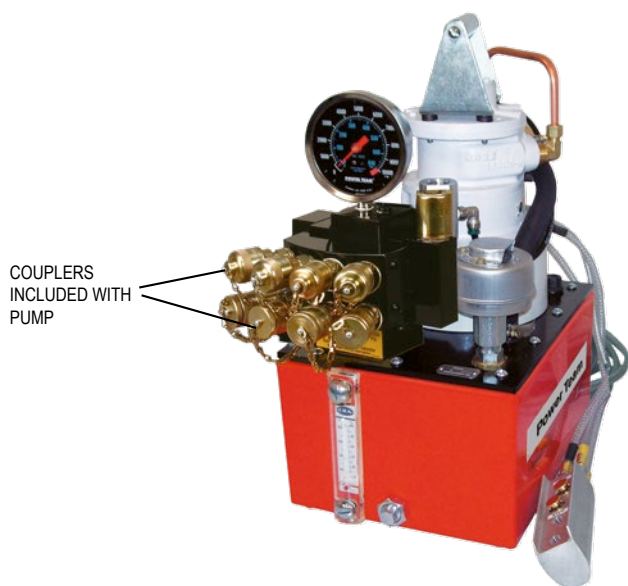

**Features**

**AIR HYDRAULIC TORQUE WRENCH PUMP**

- Use where air is the preferred source of power.
- Powerful 2,2 Kw motor starts under load.
- External adjustable pressure regulator.
- Retract side internal relief valve protects tools.
- Use for single or double-acting tools.
- Four-tool manifold allows use of up to four tools simultaneously.
- 7,6 m. pneumatic remote controller included.



**CAUTION**

**THIS PUMP SHOULD NOT BE USED FOR LIFTING APPLICATIONS, IT'S DESIGN FOR TORQUE WRENCH APPLICATIONS ONLY.**

Tools

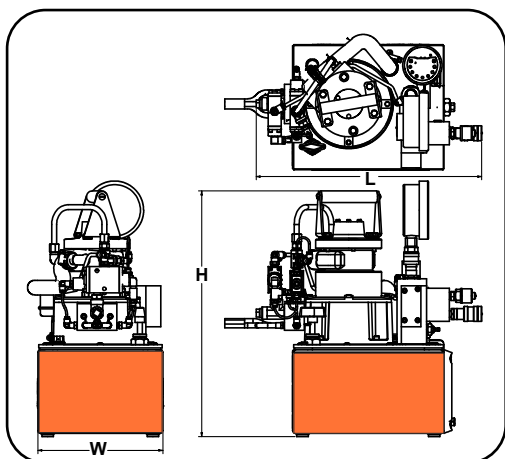

**Ordering Information**

Order No.	Width (mm)	Length (mm)	Height (mm)	Air Motor	Oil Delivery (l/min.)	Oil Reservoir Cap. (l)	Usable Oil (l)	Prod. Wt. (kg)
RWP55	450	280	483	2,25 Kw, 1,4 m <sup>3</sup> @ 6 bar	7,6 @ 7 Bar 0,9 @ 700 Bar	9,5	8,4	44
RWP55-4 (4-TOOL MANIFOLD)	450	280	483	2,25 Kw, 1,4 m <sup>3</sup> @ 6 bar	7,6 @ 7 Bar 0,9 @ 700 Bar	9,5	8,4	44

Model Shown:

**HNS150, HNS150A, HNS225**

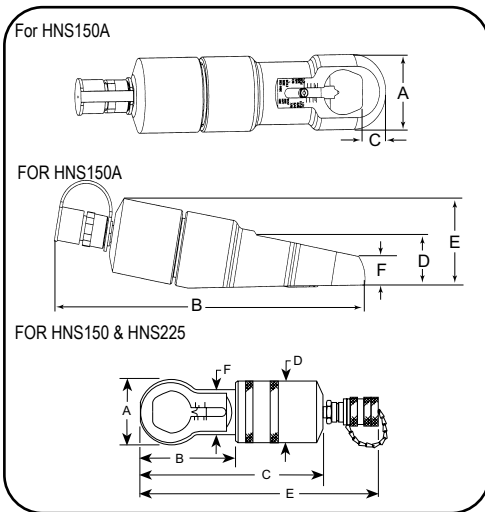

**Features**

**HYDRAULIC NUT SPLITTERS**

- Specially designed “tool steel” cutter blade penetrates the nut to the precise point where it cracks, stopping short of the bolt threads.
- Dial-in” feature on HNS150 makes adjustment of splitter simple, without the worry of damaging the bolt.
- Nut splitter features a dramatically improved cutter blade with an 800% greater resistance to chipping and breaking over previous models.
- Compact size allows you to use it in confined areas where it will deliver enough force to split the toughest “fused” or rusted-on grade 2H nuts.
- All models feature a rugged one-piece cutting frame coupled to a heavy-duty hydraulic cylinder.

▶ **Align mark on cutter blade with scale.**



▶ **Ordering Information**

Order No.	A	B	C	D	E	F	Head Thickness (mm)	Replacement Blade	Prod. Wt. (kg)
	(mm)	(mm)	(mm)	(mm)	(mm)	(mm)			
HNS150	73	86	200	70	264	53	25,4	308840	3,7
HNS150A	77	361	27	54	94	30	25,4	351985	7,2
HNS225	108	153	366	99	—	82	38,1	308022	13,2

**NUT GRADE CAPACITIES**

Order No.	2 or A	5 or B	8 or C	2DRH
HNS150	12,7 - 38,1 mm hex	12,7 - 38,1 mm hex	12,7 - 33 mm hex	12,7 - 29 mm hex
HNS150A	12,7 - 36 mm hex	12,7 - 36 mm hex	12,7 - 33 mm hex	12,7 - 29 mm hex
HNS225	29 - 57 mm hex	54 - 57 mm hex	29 - 55 mm hex	29 - 43 mm hex

Model Shown:

**FLS15, FLS15-ST**



**Features**

**INTEGRATED WEDGE CONCEPT IDEAL FOR CREATING SPACE FOR FLANGE SURFACE CLEANING AND REPAIR**

- 15 Metric Ton wedge-driven spreader. Jaws fully supported by wedge for excellent durability.
- Low friction provided by heavy-duty extended-life lubricant, ideal for flanges with narrow gaps (only 5 mm required for entry).
- Compact and lightweight design (only 252 mm long at a weight of 3,2 kg).
- Ergonomically balanced handle included.
- Suitable for the offshore environment due to superior corrosion resistance
- Quick adjustments for various tasks due to interchangeable shoes (both stepped and serrated)
- Easy and quick maintenance without special tools required.
- Includes female half coupler & mates to standard 3/8" male half coupler (9798).

**FLS15 Spreader**

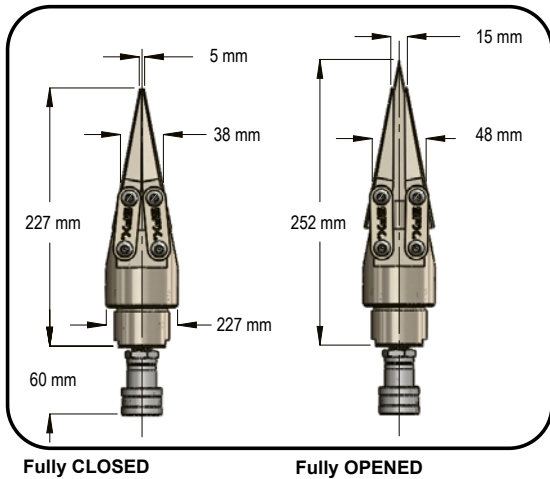

**FLS15-ST Spreader**

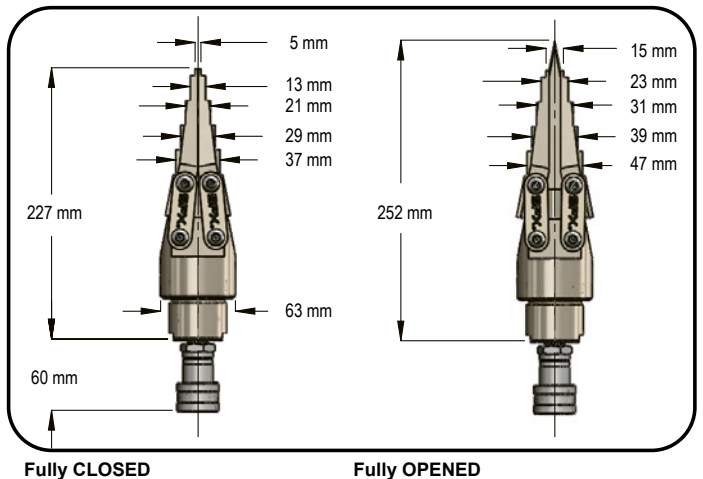

Tools

Order No.	Maximum Spreading Force	Minimum Tip Clearance (mm)	Maximum Tip Spread (mm)	Spreader Type	Oil Cap. (cm <sup>3</sup> )	Maximum Operating Pressure (bar)	Prod. Weight (kg)
FLS15 FLS15-ST	15 metric tons	5	10 mm pro hub	Hydraulic	16	700	3,2

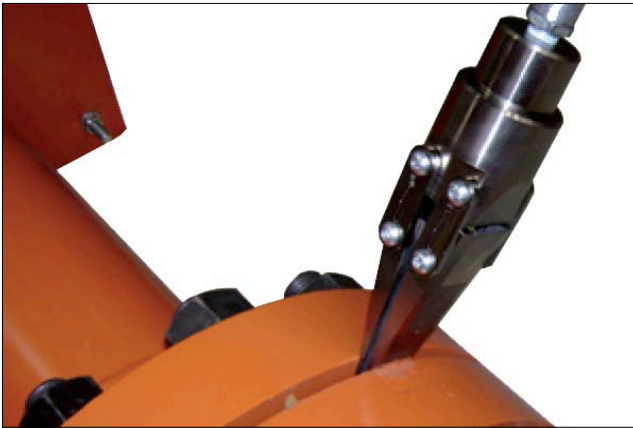

**Features**

**TYPICAL APPLICATIONS:**

- Pipe and flange repair
- Removing elbows
- Couplers & gasket and metal seal replacement
- Heavy equipment maintenance

**OTHER OPTIONAL ACCESSORIES**

HANDLE		
	Order No.	Description
	2008410	Lightweight spreaders handle is designed for use with FLS15 or FLS15-ST. Wt., 55 g.

STEPPED BLOCK		
	Order No.	Description
	SB15	Use to increase the wedge opening. Designed to use with FLS15 or FLS15-ST. (1 piece).



STEPPED SHOE		
	Order No.	Description
	2008033*	Lightweight spreader stepped shoe with an interlocking friction-free smooth, parallel wedge design. Wt. 290 g.

SERRATED SHOE		
	Order No.	Description
	2008082*	Lightweight spreader serrated shoe. Part number is for one shoe only. Two shoes required per spreader.

PUMP		
	Order No.	Description
	P19L	Two-speed, single-acting hand pump. 0,5 l oil capacity. Wt. 2,3 kg.

HOSE		
	Order No.	Description
	9764E	Hydraulic hose assembly.

ANALOG GAUGE		
	Order No.	Description
	9040E	Pressure gauge.

COUPLER & GAUGE ADAPTER		
	Order No.	Description
	9798	Male half coupler.
	9670	Gauge adapter

\*Part number is for one shoe only. Two shoes required for each spreader.

Tools

Model Shown:  
**HFS3A**



▶ **HFS6AP59L** spreader offers up to 10 tons of spreading force to safely separate this flange.

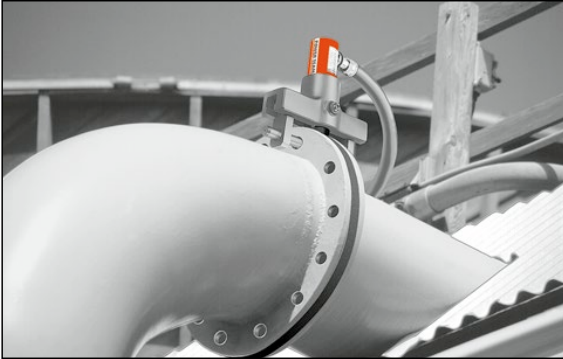

**Features**

**CONTROLLED AND GUIDED FLANGE SEPARATION TOOL**

- You'll never again have to resort to "hammer and chisel" methods that waste time and effort. Flange spreaders should be used in pairs to provide even spreading force.
- Use HFS3A for applications where total thickness of flanges and max. spread gap is 76,2 mm or less, and flange bolts are a min. of 17,5 mm diameter.
- Use HFS6A if total thickness of flanges and max. spread gap is 152,6 mm or less, and flange bolts are a min. of 20,7 mm diameter.



**Optional Wedge Ends**

Standard 60° wedge is suitable for most flanges; 30° "thin" and 60° "blunt" wedges are optional.



350823



350822



350549



350550

▶ **Ordering Information**

Order No.	Cap. (ton)	Standard Wedge Type	Optional Wedges		Min. Flange Opening			Min. Flange Opening			Min. Combined Flange Opening (mm)	Pin Dia. (mm)	Prod. Wt. (kg)
			30° Thin	60° Blunt	60° Std.	60° Blunt	30°	60° Std.	60° Blunt	30°			
					(mm)	(mm)	(mm)	(mm)	(mm)	(mm)			
HFS3A	4,5	60° Sharp	350823	350822	1,6	25,4	1,6	38,1	38,1	18,3	76,2	17,4	4,1
HFS6A	9	60° Sharp	350549	350550	1,6	38,1	1,6	50,8	50,8	24,6	152,4	20,6	8,2

Model Shown:

**HS2000, HS3000**



**Features**

**HYDRAULIC SPREADERS OFFER A GREATER FORCE THAN TRADITIONAL MECHANICAL TOOLS.**

- Use to lift machines to spread concrete forms or rebar and perform straightening jobs.
- Conforms to ASME B30.1 standard.
- High strength alloy steel forged upper and lower jaws on HS2000.
- Jaws are spring-return to retract automatically when pressure is released.

**HS2000 (FORGED STEEL)**

- 1 ton capacity spreader, full 908 kg capacity at 700 bar with 102 mm spread.
- Can be “dead-ended” at 102 mm spread under full load.
- Needs only 14,2 mm clearance to engage jaws.

**HS3000 (HIGH GRADE DUCTILE IRON)**

- 1.5 ton capacity spreader, full 1362 kg capacity at 700 bar. with 292 mm spread.
- Needs only 30,2 mm clearance to engage jaws.
- Can be “dead-ended” at 292 mm spread at full load.

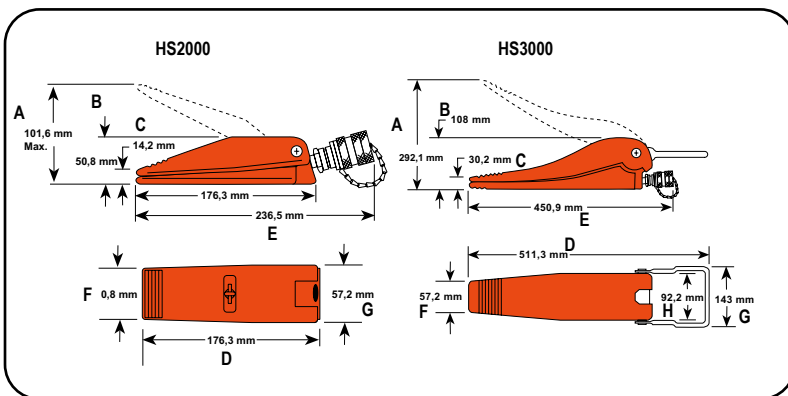

**Ordering Information**

Order No.	Cap. (ton)	Max. Spread (mm)	A	B	C	D	E	F	G	H	Oil Cap. (cm <sup>3</sup> )	Min. Clearance Required (mm)	Prod. Wt. (kg)
			(mm)	(mm)	(mm)	(mm)	(mm)	(mm)	(mm)				
HS2000	1,0	101,6	101,6	50,4	14,3	252,5	236,5	50,8	176,0	57,0	4	14,2	2,2
HS3000	1,5	292,0	292,0	108,0	30,2	—	451,0	57,2	511,0	143,0	92	30,2	10,0

Model Shown with Cylinder:  
**CC10**



**Features**

- In 4,5 , 9 and 23 ton capacities. For use with Power Team general purpose single-acting series cylinders of comparable capacity.
- Clamps withstand full rated capacity of the cylinders for which they are intended.
- For clamping, pressing and bending. Ideal for welding and metal fabrication for fit-up of sheet or plate steel.
- **Cylinder not included**

**Note:** To minimize the effects of off-center loading, the CC5, CC10 and CC25 should be used with the optional 350144 and 350145 swivel caps.

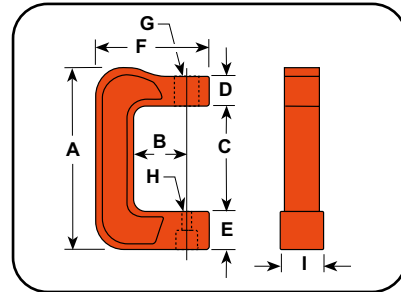

**Ordering Information**

Order No.	Cap.	A	B	C	D	E	F	G	H	I	Use With Cyl. No.	Prod. Wt. (kg)
	(ton)	(mm)	(mm)	(mm)	(mm)	(mm)	(mm)	(in.)	(mm)	(mm)		
CC5	4,5	314,0	95,3	186,0	50,8	63,5	197,0	1 1/2" - 16 UN	22,2	76,2	C51C-C57C	11,3
CC10	9	403,0	152,4	240,0	50,8	85,8	273,0	2 1/4" - 14 UNS	22,2	88,9	C101C-C1010C	20,9
CC25	23	533,0	152,4	319,0	76,2	117,3	313,0	3 5/16" - 12 UNS	36,5	117,5	C251C-C2514C	41,3

**Features**

**OTHER OPTIONAL ACCESSORIES WITH CC5, CC10 & CC25 HYDRAULIC CLAMPS**

SWIVEL CAPS					
	Order No.	Cap.	A	B	
		(ton)	(mm)	(mm)	
	350144 *	4,5 - 9	35,0	19,0	
350145	23	50,8	25,4		

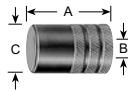
PUSHING ADAPTERS					
	Order No.	Cap.	A	B	C
		(ton)	(mm)	(in.)	(mm)
	28228**	9	60,3	1 - 8	38,1
28229**	23	73,0	1 1/4 - 7	44,5	

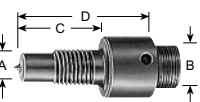
THREADED ADAPTERS						
	Order No.	Cap.	A	B	C	D
		(ton)	(in.)	(in.)	(mm)	(mm)
	38597	9	1 - 8	1 - 8	19,0	50,8
38953	23	1.5-16	1 1/4 - 7	70,0	111,0	

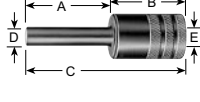
PUSHING ADAPTERS							
	Order No.	Cap.	A	B	C	D	E
		(ton)	(mm)	(mm)	(mm)	(mm)	(in.)
	201923**	9	79,4	57,2	136,5	12,7	1 - 8
34510**	23	82,6	66,7	149,0	19,0	1 1/4 - 7	

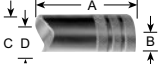
V PUSHING ADAPTERS					
	Order No.	Cap.	A	B	C
		(ton)	(mm)	(in.)	(mm)
	34806**	9	66,7	1 - 8	38,1
34807**	23	79,4	1 1/4 - 7	44,5	31,8

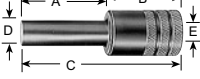
PUSHING ADAPTERS							
	Order No.	Cap.	A	B	C	D	E
		(ton)	(mm)	(mm)	(mm)	(mm)	(in.)
	201454**	9	79,4	57,2	137,0	19,0	1 - 8
34511**	23	82,6	66,7	149,0	25,4	1 1/4 - 7	

\* May be used with CC5

\*\* Must be used with a threaded adapter.

PUSHING ADAPTERS					
	Order No.	Cap.	A	B	C
		(ton)	(mm)	(mm)	(mm)
	309874*	4,5	51,6	562,8	15,9

Model Shown:  
**HP35S**

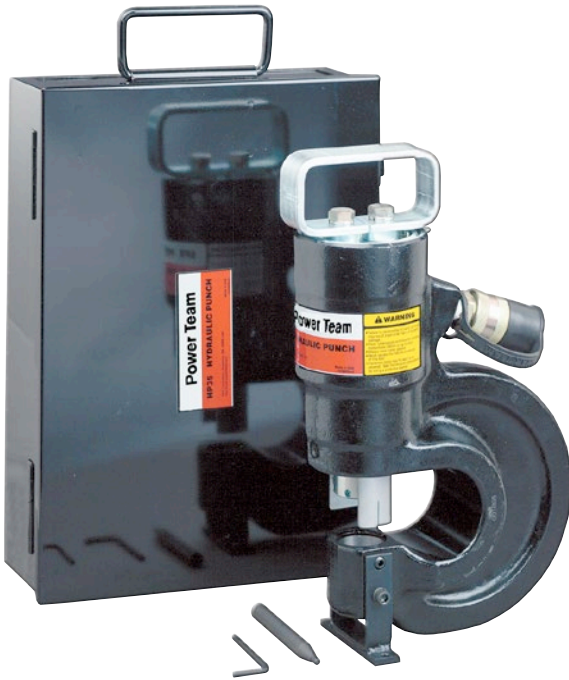

**Features**

- Punch smooth, precise holes in seconds. Much faster than drilling.
- Fully portable for construction, maintenance and service applications, or can be mounted on a workbench for production jobs.
- Has carrying handle for precise locating.
- Rugged, forged steel C-Frame for great strength and durability.
- Dual-action, spring-loaded stripper holds material during punching operation, strips material from punch on return. Scribe lines on stripper aid in locating the punch.

Tools

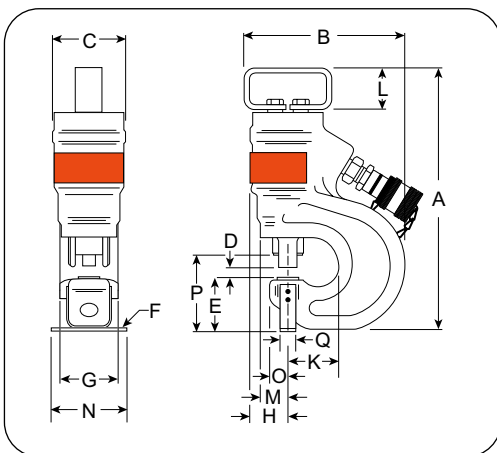

**Recommended Products**

The PE172 electric/hydraulic pump is an ideal power source, which is included in item # HP35SP.

**Technical Dimensions**

Order No.	Cap. (ton)	Max. Oper. Press. (bar)	Oil Cap. (cm <sup>3</sup> )	Max. Material Thickness (mm)	A (mm)	B (mm)	C (mm)	D (mm)	E (mm)	F (mm)	G (mm)	H (mm)	K (mm)	L (mm)	M (mm)	N (mm)	O (mm)	P (mm)	Q (mm)
HP35	32	700	75	12,7	349	229	95	15	73	6	76	46	71	57	38	89	22	102	19

Model Shown:  
**HP35SP**

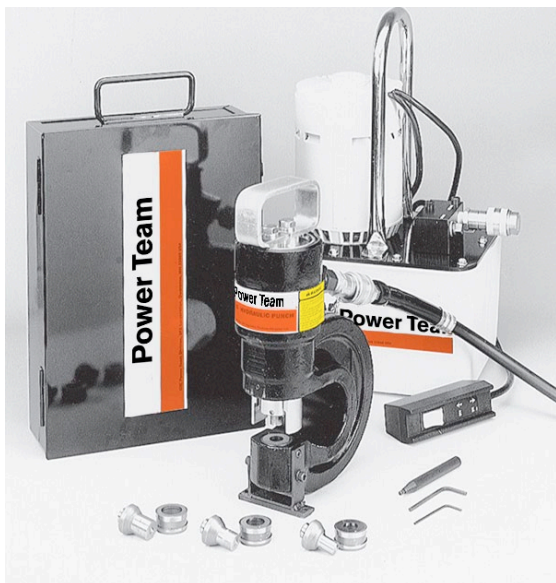

► **Ordering Information**

Order No.	Description	Prod. Wt. (kg)
HP35	Punch only, includes metal case and die change tools.	19
HP35S	Punch with punches and dies. Includes HP35 punch, metal case and 250459 punch/die set.	20
HP35P-220	Punch set with pump. Same as HP35SP, but does not include punch/die set.	39
HP35SP-E220	Punch set with pump. Includes HP35 punch, PE172-E220 electric/hydraulic pump, 9756E hose, 9798 hose half coupler, 250459 punch/die set, metal case.	40
250459	Punch/die set for round holes. Includes one each: PD437 11,1 mm punch/die, PD562 14,3 mm punch/die, PD688 17,5 mm punch/die, PD812 20,6 mm punch/die.	0,7

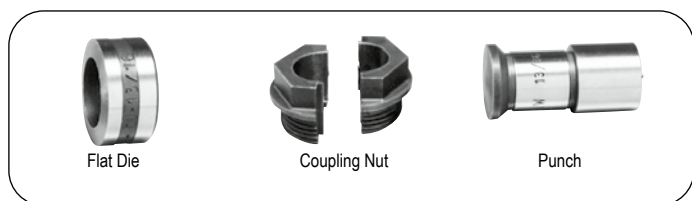

🛒
**Optional Coupling Nut Wrench**

	Order No.	Description
	252000	Makes punch/die changes easier without "rounding-off" coupling nuts. Wt., 0,3 kg.

Tools

**PUNCH / DIE SETS FOR HP35 HYDRAULIC PUNCHES**

Punch Size (mm)	Punch Style	Hole Dia. (mm)	Punch with Flat Die Set	Punch with Bevel Die Set
6,4	○ Round	6,4	—	—
7,9		7,9	PD313	—
9,7		9,7	PD375	PD375B
11,2		11,2	PD437	PD437B
13,5		13,5	PD531	PD531B
14,2		14,2	PD562	PD562B
17,5		17,5	PD688	—
19,8		19,8	PD781	—
20,6		20,6	PD812	—

Model Shown:  
**HT200**



**Features**  
**300 AND 750 L/MIN IN-LINE HYDRAULIC TESTERS**

- Accurately measure oil flow, pressure and temperature on in-plant equipment, forklifts, machine tools and more.
- Temperature and flow readings are in Imperial and Metric and accurate to within  $\pm 2\%$  of full scale.
- Dual pressure gauges for high and low pressure readings. Low pressure gauge is automatically shut-off and protected as pressure rises beyond its maximum reading.
- Automatic pressure compensating feature lets you increase flow without affecting pressure setting.
- Reverse flow through tester will not cause damage. A replaceable safety disc ruptures if pressure exceeds upper limit.
- Solid state voltage regulator eliminates errors caused by voltage change during testing.

Tools

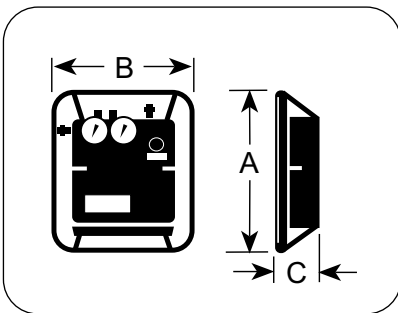

**Ordering Information**

Order No.	Max. Flow (l/min.)	Scale	Flow Range		Max. Oper. Press. (bar)	Temp. Scale Range (°C)	Port Sizes	A	B	C	Prod. Wt. (kg)
			(gpm)	(l/min.)				(mm)	(mm)	(mm)	
HT75	300	High	15 - 75	50 - 300	345	40 - 120	3/4" NPT Swivel	349,3	301,6	146,0	8,6
		Low	3 - 15	10 - 60							
HT200	750	High	25 - 200	100 - 750	345	40 - 120	1 1/2" SAE Split Flange	403,5	336,6	171,5	13,6
		Low	5 - 40	20 - 150							

**AUXILIARY POWER CORDS FOR USE WITH 300 AND 750 L/MIN TESTERS**

	<b>CAUTION:</b> For use on negative ground systems only.	
	Order No.	Description
	37045	Auxiliary power cord. For use with any 12 or 24V battery to remotely power tester. Wt. 0,5 kg.

**HOSES**

	Order No.	Description
	9785	Hose, 19,1 mm I.D. x 3/4" NPTF male both ends. 3 m. length. 155 bar working pressure. (2 req'd on 200 and 300 l/min testers). Wt., 3 kg.
	9786 *	Hose, 25,4 mm I.D. x 1-1/4" NPT male both ends. Recommended max. flow 340 l/min., with a working pressure of 280 bar. Wt., 6,3 kg.
	9787 *	Hose, 31,8 mm I.D. x 1-1/4" NPT male both ends. Recommended max. flow 530 l/min., with a working pressure of 210 bar. Wt., 6,4 kg.
	9788 *	Hose, 38,1 mm I.D. x 1-1/2" NPT male both ends. Recommended max. flow 750 l/min., with a working pressure of 175 bar. Wt., 11,4 kg.

\*Hose assemblies are all 4-ply spiral wound wire, 10 ft. long. For use with 200 gpm testers.

**HOSE REDUCER BUSHINGS**

	Order No.	Description
	203264	Consists of two hose reducer bushings, 1-1/4" NPT female x 1-1/2" NPT male end. Needed to adapt 9786 25,4 mm I.D. hose and 9787 31,8 mm I.D. hose to tester. Wt., 1 kg.

**Typical Set-up: Testing the pump, relief valve, and directional valve**

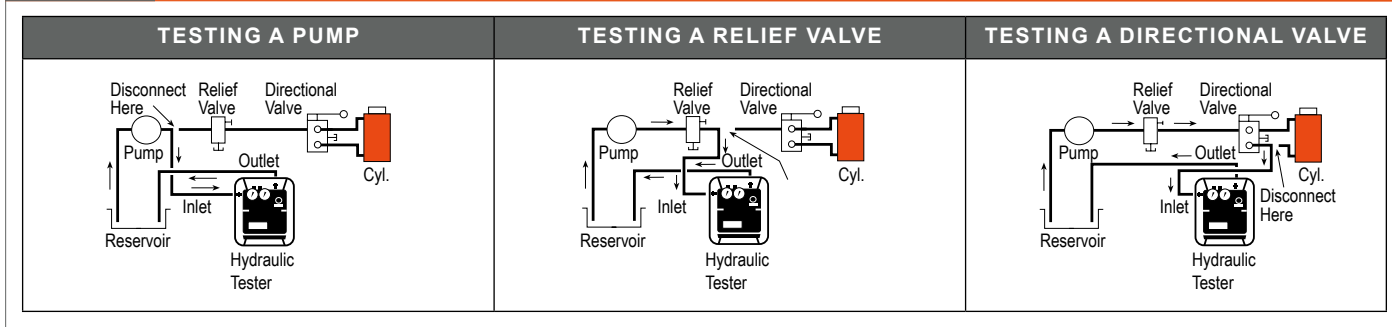

Tools

**HYDRAULIC FITTINGS FOR USE WITH ALL TESTERS.**

	<b>16954</b>	<b>90° Swivel Adapter.</b> 3/4" NPTF male x 3/4" NPSM female. Wt., 0,4 kg.		<b>26073</b>	<b>Swivel adapter.</b> 3/4" NPTF female x 1/2" NPSM female. Wt., 0,1 kg.
	<b>22041</b>	<b>Coupler.</b> 3/4" NPTF male x 3/4"-16 female ORB. Wt., 0,2 kg.		<b>26074</b>	<b>45° Swivel Adapter.</b> 3/4" NPSM female x 3/4" NPTF male. Wt., 0,3 kg.
	<b>22042</b>	<b>Coupler.</b> 3/4" -16 female ORB x 1-1/16"-12 female 37° JIC. Wt., 0,2 kg.		<b>26075</b>	<b>Swivel Adapter.</b> 3/4" NPSM female x 3/4" NPTF female. Wt., 0,2 kg.
	<b>22043</b>	<b>Coupler.</b> 3/4" -16 female ORB x 9/16"-18 female 37° JIC. Wt., 0,2 kg.		<b>26076</b>	<b>Swivel Adapter.</b> 3/4" NPTF male x 3/4" NPSM female. Wt., 0,2 kg.
	<b>22044</b>	<b>Coupler.</b> 3/4" -16 female ORB x 1/2" - 20 female 37° JIC. Wt., 0,2 kg.		<b>26077</b>	<b>Cap.</b> 3/4" NPTF. Wt., 0,3 kg.
	<b>27737</b>	<b>Swivel Adapter.</b> 3/4" -16 male x 3/4" NPSM female. For use with No. 9785 hose, which has 3/4" NPTF male thread. Wt., 0,1 kg.		<b>26078</b>	<b>Plug.</b> 3/4" NPTF. Wt., 0,1 kg.
	<b>27287</b>	<b>Coupler.</b> 3/4" -16 UNF female ORB x 7/8"-14 UNF female 37° JIC. Wt., 0,2 kg.		<b>26079</b>	<b>Adapter.</b> 3/4" NPTF female x 1-1/16" -12 male ORB. Wt., 0,2 kg.
	<b>13449</b>	<b>Cap.</b> 1-1/16"-12 UNF female, 3/4" O.D. tube, 37° flare. Wt., 0,1 kg.		<b>208402</b>	<b>45° Union Adapter.</b> 7/8"-14 UNF male 37° JIC x 3/4" NPTF female. 3,000 psi working pressure. Wt., 0,3 kg.
	<b>26068</b>	<b>45° Swivel Adapter.</b> 1" NPTF male x 3/4" NPSM female. Wt., 0,4 kg.		<b>208401</b>	<b>45° Union Adapter.</b> 7/8"-14 UNF male 37° JIC x 3/4" NPTF female. Wt., 0,4 kg.
	<b>26069</b>	<b>Swivel Adapter.</b> 1" NPTF female x 3/4" NPSM female. Wt., 0,2 kg.		<b>206753</b>	<b>Coupler.</b> 1-15/16"-12 UNF female 37° JIC x 3/4" NPTF female. Wt., 0,5 kgs.
	<b>26070</b>	<b>Adapter.</b> 1" NPTF male x 3/4" NPTF female. Wt., 0,1 kg.		<b>26666</b>	<b>Connector.</b> 1-5/16"-12 UNF male 37° JIC x 3/4" NPTF male. Wt., 0,2 kg.
	<b>26071</b>	<b>Service Tee.</b> 3/4" NPTF female (2) x 3/4" NPTF male. Wt., 0,4 kg.		<b>28984</b>	<b>Straight Adapter.</b> 3/4" NPTF female x 1-3/16" -12 UN male 37° JIC. Wt., 0,3 kg.
	<b>26072</b>	<b>Swivel Adapter.</b> 3/4" NPSM female x 1/2" NPTF male. Wt., 0,2 kg.		<b>28985</b>	<b>Straight Adapter Union.</b> 1-3/16"-12 UN female 37° JIC x 3/4" NPTF female. Wt., 0,6 kgs.

NOTE: The recommended maximum working pressure on the above fittings is 350 bar (except the 208402 is 210 bar).

**HT200 HYDRAULIC TESTER ACCESSORIES**

Attach to the HT200 hydraulic tester by the use of flanged-head adapters and split flanges, or by a set of female straight adapters.



**FLANGED HEAD ADAPTER UNIONS & SPLIT FLANGE KIT**

Order No.	Description
<b>203154</b>	<b>Straight flange adapter.</b> 38,1 mm flanged-head to 1-1/2" NPSM female swivel. Wt., 1 kg.
<b>203155</b>	<b>45° flange adapter.</b> 38,1 mm flanged-head by 1-1/2" NPSM female swivel. Wt., 1,5 kg.
<b>203156</b>	<b>90° flange adapter.</b> 38,1 mm flanged-head by 1-1/2" NPSM female swivel. Wt., 1,9 kg.
<b>203017</b>	<b>Split Flange Kit.</b> Consists of four flange halves and attaching bolts to permit use of 38,1 mm I.D. flange adapters listed at left. Wt., 1,3 kg.

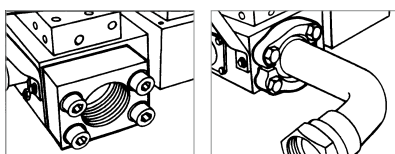

**FEMALE STRAIGHT FLANGE ADAPTER**

Order No.	Description
<b>203003</b>	Consists of two female straight flange adapters with attaching bolts. When attached to inlet/outlet ports, allows connection of 1-1/2" NPT male hose ends to tester. Wt., 3,9 kg.

**HORSESHOE LOCK RING PLIER**



For removing horseshoe lock rings used on hydraulic brakes, differentials, etc. Plier is 203 mm long; max. spread: 23,8 mm

Order No.	Description
714	Horseshoe lock ring plier. Wt., 0,2 kg.
7313	External snap ring plier easily removes snap rings used to retain bearings on shafts. Max. spread: 27 mm.

**RETAINING RING PLIER KITS**

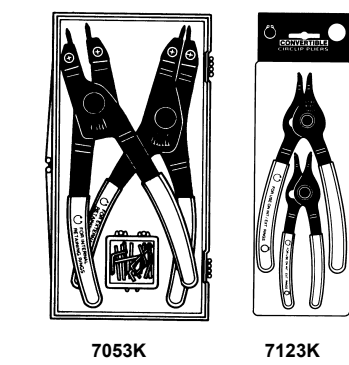

Choose from four sets; internal ring, external ring and convertible pliers for either internal or external rings.

Order No.	Description
7053K	Replaceable tip pliers kit. This versatile kit contains (1) internal and (1) external pliers with (8) tip sets. Two sets each: 0,9 mm dia. 90° bend, 1,2 mm dia. straight, 1,2 mm dia. 90° bend, 1,8 mm dia. straight. Recommended for 6,4 - 51 mm rings. Packaged in plastic storage case. Wt., 0,4 kg.
15702	Replaceable tip kit (only) for 7053K.
7123K	Convertible pliers kit. Contains 1120 (1 mm dia./straight tip) and No. 1340 (1,8 mm dia./straight tip). Each pliers "converts" to handle both internal and external rings. Packaged in a reusable plastic storage case. Wt., 0,4 kg.
7125K	Convertible pliers kit. Contains 1125 (.038" dia./45° bent tip) and No. 1345 (.070" dia./45° bent tip). Each pliers "converts" to handle both internal and external rings. Packaged in a reusable plastic storage case. Wt., 0,4 kg.



Order No.	Description
7406K	Professional pliers kit. Contains (6) retaining convertible pliers to handle both internal and external rings from 6,4 - 51 mm. Includes straight and 90° off-set pliers with 1, 1,2 , and 1,8 mm tip diameters. Includes Nos. 1120, 1131, 1320, 1329, 1340 and 1349. Packaged in an impact resistant storage case. Wt., 0,9 kg.

**REPLACEMENT TIPS FOR 7300 AND 7301 PLIERS**

Order No.	Description
209201	Replacement tips (pr.) for the 7300 and 7301 pliers. Wt., 0,1 kg. Fed. Spec.:GGG-P-480

**RETAINING RING PLIERS SELECTION GUIDE**

Order No.	Type of Pliers	Tip Bend	Tip Size Dia. (mm)	For Internal Rings † Bore Dia. (mm)	For External Rings † Shaft Dia. (mm)	Order No.	Type of Pliers	Tip Bend	Tip Size Dia. (mm)	For Internal Rings † Bore Dia. (mm)	For External Rings † Shaft Dia. (mm)
0100	Internal	Str.	1	9,5 - 26	—	1120	Convertible	Str.	1	9,5 - 14	6,4 - 17
0200	External	Str.	1	—	6,4 - 22	1125*	Convertible	45°	1	9,5 - 14	6,4 - 17
0300	Internal	Str.	1,8	27 - 44,5	—	1131**	Convertible	90°	1	9,5 - 14	6,4 - 17
0400	External	Str.	1,8	—	24 - 36,5	1320	Convertible	Str.	1,2	16 - 26	17 - 22
0500	Internal	Str.	2,3	46 - 89	—	1329	Convertible	90°	1,2	16 - 26	17 - 22
0600	External	Str.	2,9	—	38 - 89	1340	Convertible	Str.	1,8	27 - 44,5	24 - 36,5
7300	Internal	Str.	3	78 - 152	—	1345*	Convertible	45°	1,8	27 - 44,5	24 - 36,5
7301	External	Str.	3	—	38 - 165	1349**	Convertible	90°	1,8	27 - 44,5	24 - 36,5

Fed. Spec.:GGG-P-480-E

\* 45° Angled Tips

\*\* 90° Angled Tips

† Capacities are shown for basic style rings.

**CAUTION:** Always wear safety goggles when using pliers

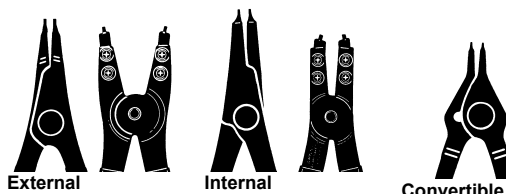



External



Internal

Convertible

**RATCHETING CHAIN WRENCHES**

	Special head design allows you to turn wrench in either direction. Ratcheting action makes it possible to re-grip without removal. Fits parts of most any size and shape.	
	Order No.	Description
	7400	Chain wrench, cap. 12,7 to 121 mm O.D. (Capacity= 450 Nm.) Handle length: 317,5 mm. Wt., 0,9 kg.
	209199	Replacement chain with pin for 7400 chain wrench (406 mm long).
	7401	Chain wrench, cap. 76 to 171 mm O.D. (Capacity= 900 Nm) Handle length: 19.00" Wt., 2,3 kg.
	209200	Replacement chain with pin for 7401 chain wrench (610 mm long).

**PRY BARS**

	Our rolling head pry bars are an extremely popular and useful tool. Head may be used for almost any prying job since a great deal of leverage can be obtained. Long tapered body may be used as a lining-up drift.	
	Order No.	Description
	7162	Pry bar; 9,5 mm round, 152 mm long. Wt., 0,1 kg.
	7163	Pry bar; 11,1 mm round, 305 mm long. Wt., 0,3 kg.
	7164	Pry bar; 14,3 mm round, 406 mm long. Wt., 0,5 kgs.
	7165	Pry bar; 19 mm round, 457 mm long. Wt., 1 kg.

**ADJUSTABLE GLAND NUT WRENCH**

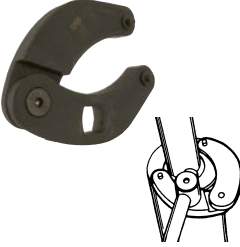
	Designed to handle 51 to 152 mm dia. hydraulic cylinder gland nuts on many construction vehicles. Fits 6,4 and 7,9 mm dia. pin holes. Features a 3/4" sq. drive.	
	Order No.	Description
	1266	Adjustable gland nut wrench. Wt., 1,4 kg.
	204928	Replacement pin for 1266 (2 required)

**JIMMY BARS**

	Ideal for general lifting or prying. Heat treated chrome alloy steel to resist bending or breaking.	
	Order No.	Description
	7166	Jimmy bar; 15,9 mm round, 457 mm long. Wt., 0,6 kg.
	7167	Jimmy bar; 19 mm round, 610 mm long. Wt., 1,1 kg.
	7168	Jimmy bar; 22,2 mm round, 762 mm long. Wt., 1 kg.

**ADJUSTABLE HOOK SPANNER WRENCH**

	Needed wherever turret adjusting nuts or packing gland nuts are used. Adjust 38 to 102 mm. Handle overall length: 483 mm.	
	Order No.	Description
	885	Adjustable hook spanner wrench. Wt., 1,4 kg.

**"MAJOR PERSUADER" JIMMY BARS**

	Two big jimmy bars for big jobs. Forged from chrome alloy steel.	
	Order No.	Description
	7420	Jimmy bar; 22,2 mm round, 1168 mm long. Wt., 3,4 kg.
	7421	Jimmy bar; 25,4 mm round, 1372 mm long. Wt., 1,9 kg.

**ADJUSTABLE HOOK SPANNER WRENCH**

	Replace many fixed-size wrenches and cover a range of capacities needed to service industrial tractors and other equipment. Drop-forged jaws adjust to eleven positions for a capacity of 121 to 324 mm O.D. Handle overall length: 610 mm; diameter: 25,4 mm.	
	Order No.	Description
	7307	Spanner wrench with one 9,5 mm thick jaw. Wt., 3,3 kg.
	7308	Spanner wrench with two interchangeable jaws: one 9,5 mm thick, one 19 mm thick. Wt., 5 kg.

**HEAVY-DUTY ADJUSTABLE SPANNER**

	Extra heavy construction. Has one 19 mm thick, eleven-position hook-jaw for a capacity of 131 to 324 mm O.D. Drop-forged. Handle length: 654 mm; handle dia.: 33,3 mm.	
	Order No.	Description
	7309	Heavy-duty adjustable hook spanner wrench. Wt., 5 kg.

**HTS50 HEAVY-DUTY PIPE SEALANT WITH PTFE**



- Seals new or damaged threads; resists water, chemicals and oils.
- Replaces conventional tape methods; forms a clog-free seal.
- Effective at 700 Bar.

When “plumbing” a hydraulic system, there’s now a better answer than tapes which can tear or shred, possibly plugging filters, valves or gauges. This compound combines the lubricating qualities of PTFE with a fast curing anaerobic sealant. Seals all metal fittings, plugs and threaded joints quickly and easily. Cures to form a permanent seal which is inert to hydrocarbons, most acids, chemicals, solvents and steam. Allows adjustment up to 16 hours after assembly; won’t loosen under vibration. Prevents galling of mating parts upon disassembly. Withstands temperatures from -54° C to 190° C.

**Note:** Product labeling may vary from picture.

Order No.	Description
HTS50	Sealant, 50 ml. tube. Wt., 0,2 kg.

**O-RING SEAL PICKS**

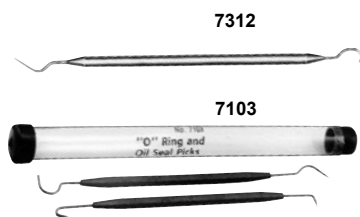

Even the seemingly simple job of removing and installing O-ring seals can be difficult without the aid of the proper tool. The 7312 is constructed with plastic & steel O-ring seal pick does the job with ease. Two special picks in set 7103 get right to the trouble areas.

Order No.	Description
7312	O-ring seal pick. Wt., 0,1 kg.
7103	Set of two O-ring seal picks. Wt., 0,1 kg.

**UNIVERSAL OUTSIDE THREAD CHASER**



Restore damaged threads on shafts, housings, cages, etc., for re-assembly of matching parts. Eliminates need for thread-cutting equipment. Will not harm threads. V-pads and dies can be replaced. Cap. 32 to 127 mm O.D.

Order No.	Description
7402	Thread chaser, complete (with 6 dies: threads per inch – 4, 5, 6, 7, 7.5, 8, 9, 10, 11, 11.5, 12, 14, 16, 18, 20 and 24). Wt., 0,2 kg
202817	Metric die set (3 dies: mm per thread: 1, 1.25, 1.5, 1.75, 2, 2.5, 3, 3.5, and 4). Wt., 0,1 kg.

**MAGNETIC PICK-UP TOOL**



Has permanent magnetic head for retrieving parts from otherwise inaccessible places.

Order No.	Description
7395	Pick-up tool with pocket clip. 152 mm lg. Wt., 0,1 kg.

Tools

# PULLERS

**POWER TEAM OFFERS THE WORLD'S MOST COMPLETE LINE OF PULLING EQUIPMENT, ENABLING USERS TO REMOVE AND INSTALL PARTS WITH SPEED AND SAFETY, FOR EFFECTIVE REPAIR JOBS.**

Range includes:

- Mechanical Pullers
- Hydraulic Pullers
- Puller Sets
- Bi-Directional™ Pullers
- High Tonnage Pullers
- Accessories & Adapters



Powerthon  
Limited  
**Lifetime**  
WARRANTY  
ISO 9001 Certified

Worry-Free  
Ownership



Section / Series	Page Description	Page(s)
<b>Introduction</b>	Puller Basics, Basic Puller Scenarios & Choosing the Right Puller	<b>221-222</b>
<b>PT</b>	Posi Lock® Mechanical Pullers	<b>223</b>
<b>PTTJ</b>	Posi Lock® Transmission Jaw Pullers	<b>224</b>
<b>PTPM</b>	Posi Lock® Internal Slide Hammer Pullers	<b>225</b>
<b>PTPM</b>	Posi Lock® Tool Board Sets	<b>236</b>
<b>PTPMW PTTK PTTB</b>	Posi Lock® Mechanical Puller Sets	<b>237</b>
<b>PTHP PTFR</b>	Posi Lock® Fan Removal Sets	<b>238</b>
<b>PTPH</b>	Posi Lock® Hydraulic Pullers	<b>239-232</b>
<b>PTPH</b>	Posi Lock® High Tonnage Hydraulic Pullers	<b>233-235</b>
<b>PTPHS</b>	Posi Lock® Self-Contained Pullers	<b>237</b>
<b>PTPH</b>	Posi Lock® Hydraulic Internal/External Pullers	<b>238</b>
<b>1020-1027 1035-1050</b>	Mechanical 2 & 3-Jaw Pullers	<b>239-240</b>
<b>927-939</b>	Mechanical Bi-Directional™ Pullers	<b>241-242</b>
<b>6981, SS2, 1178</b>	Blind Hole Puller Set, Slide Hammer Puller Set, Slide Hammer	<b>243</b>
<b>7136, 1173-1174, 1155-1158</b>	Bearing Cup Remover, Pilot Bearing Pullers, basic Slide Hammer Units, Reversible-Jaw Slide Hammer Pullers, Slide Hammer Pullers w/Cup Pull- ing Attachments	<b>244</b>
<b>PH63C, PH83C, PH113C, PH303C</b>	Hydra Lock-Jaw™ 2 & 3-Jaw Pullers	<b>245</b>
<b>K82-K83, HST11, 1188</b>	Lock-Jaw™ Puller Accessories Kits Hydraulic Straightening Tool, Long Jaw Set	<b>246</b>
<b>PH</b>	Hydraulic Pullers	<b>247-248</b>
<b>PPH</b>	Bi-Directional™ Hydraulic Pullers	<b>249-250</b>
<b>PHP</b>	Bearing Pusher	<b>251</b>
<b>PB</b>	Puller Blankets	<b>252</b>
<b>MB</b>	Metal Boxes	<b>252</b>
<b>PH</b>	Enforcer 55 & Enforcer 100	<b>253-254</b>
<b>PR</b>	Roller Bearing Puller/Installer	<b>255-256</b>
<b>1150-1154, 1165-1166, 1121-1130, 679-680</b>	Pulling Attachments	<b>257-258</b>
	Puller Adapters	<b>259-260</b>



► **Components Requiring Extraction**



► **Primary Markets / Applications**



**You need a firm grip,  
a straight pull and the  
proper force...**



Whether it's a gear, wheel or bearing: If you grip it by its outer edges and apply force to the shaft, you can perform a proper pulling job.

Bearing cups, retainers and seals must be gripped through their inside diameters and pulled straight out to avoid damage.

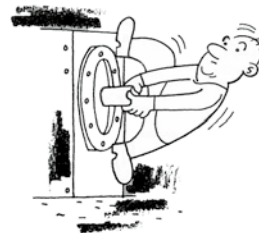

Gripping a shaft and bracing against the housing for the pull offers the best solution to this basic pulling problem.

**► Puller Selection**



Tapered jaw design allows clamping around bearing for a perfect pull.

Tapered roller bearing on shaft.

Lock on ball grooves and bearing races.

**HOW TO SELECT THE “RIGHT” PULLER**

**1. DETERMINE THE TYPE OF PULLER OR PULLER COMBINATION**

Which puller type is best for “getting a grip” on the part, internal or external puller?

**2. DETERMINE THE “REACH” NEEDED**

The puller you select must have a “reach” equal to, or larger than, the corresponding dimension of the job.

**3. DETERMINE THE “SPREAD” NEEDED**

The width of the part to be pulled will determine the “spread” required.

**4. ESTIMATE THE FORCE REQUIRED**

A puller with the proper “reach” and “spread” will usually have enough power. When in doubt, always use the next larger size... more power may be needed for rusted parts, or when the “area of resistance” is large.

**Considerations**

The “area of resistance” or “area of press fit” can vary greatly between seemingly similar jobs, such as in the example shown below. Study each pulling job before you select the puller.

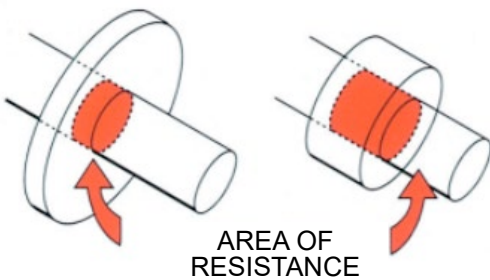

For manual, screw-powered pullers: The puller screw must be at least half as large (in diameter) as the shaft of the pulling job.

Hydraulic pullers suggestion for selection: The maximum force exerted in tons should be 7 to 10 times the diameter of the shaft in inches.

**HOW TO MEASURE “REACH” AND “SPREAD”**

“Reach” and “spread” dimensions of the job must first be determined. A typical example - a component to be removed from a shaft - is shown below. The length of the protruding shaft and the thickness of the component determine the “reach” needed. The width of the component determines the spread required.

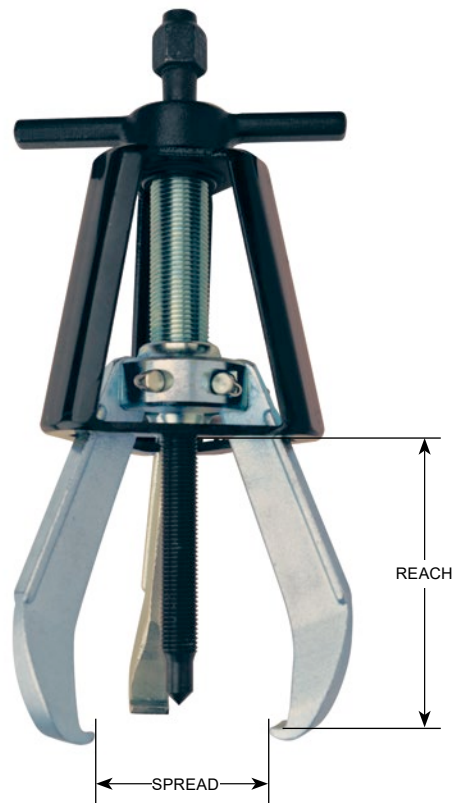
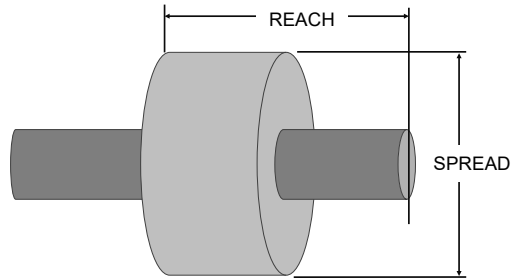

Model Shown:  
**PT110,  
PT216**

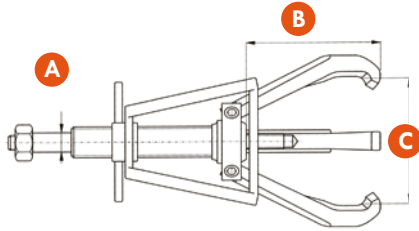

**Features**

**PULLING BEARINGS IS A ONE-PERSON OPERATION WHEN USING THE PT SERIES MECHANICAL PULLERS. OPENING, CLOSING, LOCKING, AND ALIGNING OF THE JAWS IS ALL DONE AUTOMATICALLY BY SIMPLY TURNING THE T-HANDLE.**

- 1 to 36-ton capacity puller with up to 14" (356 mm) reach and 25" (635 mm) spread for large pulling requirements
- Mechanical pullers use a rolled center bolt thread to reduce effort when applying high torque to extract objects in a controlled manner
- Recessed nut to avoid mushrooming and disfiguring
- Slim tapered heat-treated tips allow for better gripping and easier access in tight spots
- Safety Cage® guides jaws for fast set-up, solid contact and superior safety

		Long Jaws/Extra Long Jaw			Optional Accessories							
					Tip Protector	Bolt Extender	Transmission Jaws					
Order No.	Cap.	Jaws	Bolt Diameter A	Reach B	Spread C	Weight	Long Jaw/ XL Jaw	Reach	Spread	Order No.	Order No.	Order No.
	Metric Tons	Qty.	in. (mm)	in. (mm)	in. (mm)	lbs. (kg)	Order No.	in. (mm)	in. (mm)			
PT202	1	2	0.31 (7.9)	2.25 (57)	3.25 (82.6)	0.62 (0.28)	—	—	—	—	—	—
PT203	2	2	0.37 (9.4)	3.00 (76.2)	4.50 (127)	1.12 (0.51)	—	—	—	—	—	—
PT204	2	2	0.5 (12.7)	4.00 (102)	5.00 (127)	3 (1.36)	—	—	—	PTP4	PTX4	10454T
PT206	5	2	0.62 (15.8)	6.00 (152)	7.00 (178)	7 (3.18)	—	—	—	PTP6	PTX6	10654T
PT208	11	2	0.75 (19)	8.00 (203)	12.00 (305)	12 (5.44)	PT208L /PT208XL	9.8 (249) / 16.00 (406)	15.8 (401) / 22.00 (559)	PTP10	PTX10	11054T
PT210	13	2	0.75 (19)	9.67 (246)	15.00 (381)	13 (5.9)	PT210L	16.00 (406)	22.00 (559)	PTP10	PTX10	11054T
PT213	23	2	1.12 (28.5)	12.00 (305)	18.00 (457)	38 (17.24)	PT213L	20.00 (508)	30.00 (762)	PTP13/16	—	—
PT216	32	2	1.25 (32)	14.00 (356)	25.00 (635)	57 (25.85)	PT216L	26.00 (660)	38.00 (965)	PTP13/16	—	—
PT102	1	3	0.31 (7.9)	2.25 (57)	3.25 (82.6)	0.68 (0.31)	—	—	—	—	—	—
PT103	2	3	0.37 (9.4)	3.00 (76.2)	4.50 (114.3)	1.3 (0.59)	—	—	—	—	—	—
PT104	4.5	3	0.5 (12.7)	4.00 (102)	5.00 (127)	4.1 (1.86)	—	—	—	PTP4	PTX4	10454T
PT106	9	3	0.62 (15.8)	6.00 (152)	7.00 (178)	8 (3.63)	—	—	—	PTP6	PTX6	10654T
PT108	15	3	0.75 (19)	8.00 (203)	12.00 (305)	14 (6.35)	PT108L /PT108XL	9.8 (249) / 16.00 (406)	15.8 (401) / 22.00 (559)	PTP10	PTX10	11054T
PT110	18	3	0.75 (19)	9.67 (246)	15.00 (381)	16 (7.26)	PT110L	16.00 (406)	22.00 (559)	PTP10	PTX10	11054T
PT113	27	3	1.12 (28.5)	12.00 (305)	18.00 (457)	44 (19.96)	PT113L	20.00 (508)	30.00 (762)	PTP13/16	—	—
PT116	36	3	1.25 (32)	14.00 (356)	25.00 (635)	68 (30.84)	PT116L	26.00 (660)	38.00 (965)	PTP13/16	—	—

**Ordering Information**

Order No.	Cap.	Jaws	Bolt Diameter A	Reach B	Spread C	Weight	Long Jaw/ XL Jaw	Reach	Spread	Order No.	Order No.	Order No.
	Metric Tons	Qty.	in. (mm)	in. (mm)	in. (mm)	lbs. (kg)	Order No.	in. (mm)	in. (mm)			
PT202	1	2	0.31 (7.9)	2.25 (57)	3.25 (82.6)	0.62 (0.28)	—	—	—	—	—	—
PT203	2	2	0.37 (9.4)	3.00 (76.2)	4.50 (127)	1.12 (0.51)	—	—	—	—	—	—
PT204	2	2	0.5 (12.7)	4.00 (102)	5.00 (127)	3 (1.36)	—	—	—	PTP4	PTX4	10454T
PT206	5	2	0.62 (15.8)	6.00 (152)	7.00 (178)	7 (3.18)	—	—	—	PTP6	PTX6	10654T
PT208	11	2	0.75 (19)	8.00 (203)	12.00 (305)	12 (5.44)	PT208L /PT208XL	9.8 (249) / 16.00 (406)	15.8 (401) / 22.00 (559)	PTP10	PTX10	11054T
PT210	13	2	0.75 (19)	9.67 (246)	15.00 (381)	13 (5.9)	PT210L	16.00 (406)	22.00 (559)	PTP10	PTX10	11054T
PT213	23	2	1.12 (28.5)	12.00 (305)	18.00 (457)	38 (17.24)	PT213L	20.00 (508)	30.00 (762)	PTP13/16	—	—
PT216	32	2	1.25 (32)	14.00 (356)	25.00 (635)	57 (25.85)	PT216L	26.00 (660)	38.00 (965)	PTP13/16	—	—
PT102	1	3	0.31 (7.9)	2.25 (57)	3.25 (82.6)	0.68 (0.31)	—	—	—	—	—	—
PT103	2	3	0.37 (9.4)	3.00 (76.2)	4.50 (114.3)	1.3 (0.59)	—	—	—	—	—	—
PT104	4.5	3	0.5 (12.7)	4.00 (102)	5.00 (127)	4.1 (1.86)	—	—	—	PTP4	PTX4	10454T
PT106	9	3	0.62 (15.8)	6.00 (152)	7.00 (178)	8 (3.63)	—	—	—	PTP6	PTX6	10654T
PT108	15	3	0.75 (19)	8.00 (203)	12.00 (305)	14 (6.35)	PT108L /PT108XL	9.8 (249) / 16.00 (406)	15.8 (401) / 22.00 (559)	PTP10	PTX10	11054T
PT110	18	3	0.75 (19)	9.67 (246)	15.00 (381)	16 (7.26)	PT110L	16.00 (406)	22.00 (559)	PTP10	PTX10	11054T
PT113	27	3	1.12 (28.5)	12.00 (305)	18.00 (457)	44 (19.96)	PT113L	20.00 (508)	30.00 (762)	PTP13/16	—	—
PT116	36	3	1.25 (32)	14.00 (356)	25.00 (635)	68 (30.84)	PT116L	26.00 (660)	38.00 (965)	PTP13/16	—	—

Model Shown:

**PTTJ-1,  
PTTJ-2,  
PTTJ-3**



**REMOVAL OF BEARINGS, BUSHINGS, SLEEVES AND OTHER FRICTION-FITTED PARTS CAN EASILY BE ACCOMPLISHED WITH USING THE SERIES PTTJ AUTOMOTIVE TRANSMISSION PULLERS.**

- Pullers with up to 9.25" (235 mm) reach and 14.75" (375 mm) spread for large pulling requirements
- Machined jaws that clamp in snap-ring grooves as narrow as .070" (1.8 mm).
- Specially designed for transfer cases on 4-wheel-drive vehicles, output shaft bearings and numerous other applications on any vehicle
- Slim tapered heat-treated tips allow for better gripping and easier access in tight spots

Jaws that clamp in snap-ring grooves as narrow as .070" (1.8 mm)



A standard jaw (left) is compared to a specially machined transmission jaw (right).

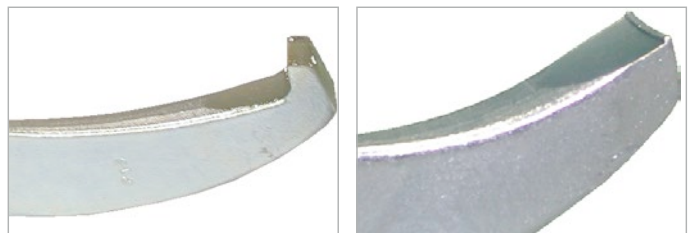

**Ordering Information**

Model	Number of Jaws	Reach in. (mm)	Spread in. (mm)	Weight lbs. (kg)	Tip Protector	Optional Accessories				
						Accessories		Optional Jaws		
						Description	Part #	Jaw Style	Reach in. (mm)	Spread in. (mm)
PTTJ-1	2	9.25 (235)	2.75 to 14.75 (70 to 375)	12 (5.4)	PTP10	Bolt Extender	PTX10	Jaw - 10854	8 (203)	.75 to 12 (19 to 305)
								Long Jaw - 11054	10 (254)	2.25 to 15 (57 to 381)
								Extra Long Jaw - 11054L	16 (406)	1.5 to 22 (38 to 559)
PTTJ-2	3	5.25 (133)	1 to 6.75 (25 to 171)	8 (3.6)	PTP6	Bolt Extender	PTX6	Jaw - 10654	6 (152)	.5 to 7 (13 to 178)
						Slide Rod Adaptor	PT10661			
						Slide Rod	PT10561			
						2.5 lb Slide Hammer	PT10562			
						5.0 lb Slide Hammer	PT10563			
PTTJ-3	3	4 (102)	.5 to 5.5 (13 to 140)	4.1 (1.9)	PTP4	TJ-3 Bolt Extender	PTX4	Jaw - 10454	4 (102)	.5 to 5 (13 to 127)
						Slide Rod	PT10561			
						2.5 lb Slide Hammer	PT10562			
						5.0 lb Slide Hammer	PT10563			

Model Shown:  
**PTPMI6**



**Features**

**DURABLE SLIDE HAMMER WITH TIGHT GRIPPING JAW DESIGN AND A SAFETY CAGE THAT GUIDES JAWS FOR FAST SET-UP, AND SOLID CONTACT FOR SUPERIOR SAFETY.**

- Long internal jaws with slim tapered heat-treated tips allow for better gripping and easier access in tight spots
- High force 2.5 lb (1.13 kg) slide hammer for an effective use of force (optional ultra high force 5.0 lb (2.27 kg) slide hammer)
- Includes 3-Jaw puller (model no. PT105)
- Includes promotional tool board
- Safety Cage® guides jaws for fast set-up, solid contact and superior safety

**Promotional Goods**

Showcase your pullers with a branded, reinforced pegboard display in your showroom or shop.

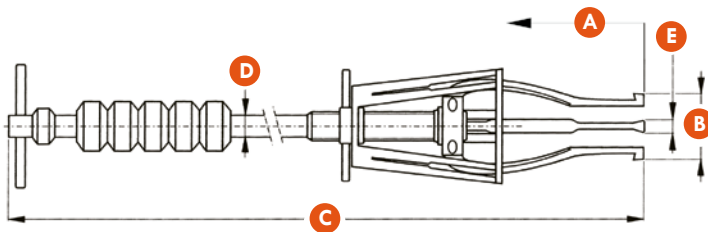

Kit Components	Description	Order No.
		PTPMI6
PT105	3-Jaw Internal Puller	1
PT10561	Slide Rod 24" (609 mm)	1
PT10562	2.5 lb. (1.13 kg) Slide Hammer	1
PT10554L	Long Jaw Set	1
2008508	Tool Board Kit, Posi Lock Tool Sets	1
PT10563	5 lb. (2.27 kg) Slide Hammer	Optional

**Ordering Information**

Model	Number of Jaws	Jaw Style	Reach	Spread Range	Slide Hammer Weight	Dimensions				Optional Accessories
			A	B		C	D	E	Slide Hammer Weight	
			in. (mm)	in. (mm)		in. (mm)	in. (mm)	in. (mm)	lbs. (kg)	
PTPMI6	3	Standard	2.78 (71)	.56-4 (14-102)	2.5 (1.1)	29 (737)	.52 (13)	.33 (8)	6.62 (168)	5 (2.3)
		Long	9 (229)	1-5.25(25-133)	2.5 (1.1)	31 (787)	.52 (13)	.33 (8)	8.62 (219)	5 (2.3)

Model Shown:

**PTP**



Peg Board with Pullers  
Order No. PTPM4L

**SHOWCASE YOUR PULLERS WITH A BRANDED, REINFORCED PEGBOARD DISPLAY IN YOUR SHOWROOM OR SHOP.**

- 6 peg board promotional kits that offer many different variations
- Order the peg board separately for even greater flexibility
- Suitable for use behind a counter, parts desk or showroom



Peg Board Only  
Order No. 2008508

**Ordering Information**

Kit Components	Description	ORDER NUMBER					
		PTPM4	PTPM4L	PTPM4S	PTPM5	PTPM6	PTMPS16
PTP13/16	TIP PROTECTOR for PT113 / PT213 / PT116 / PT216	—	—	—	—	—	4
PTP10	TIP PROTECTOR PT108 / PT208 / PT110 / PT21	1	2	—	1	2	4
PTP6	TIP PROTECTOR for PT106 / PT206	2	2	2	2	2	2
PTP4	TIP PROTECTOR for PT104 / PT204	1	—	2	1	2	2
PT216	PULLER, MANUAL 2 JAW - 32 TON	—	—	—	—	—	1
PT213	PULLER, MANUAL 2 JAW - 23 TON	—	—	—	—	—	1
PT210	PULLER, MANUAL 2 JAW - 13 TON	—	1	—	—	1	1
PT208	PULLER, MANUAL 2 JAW - 1 TON	—	—	—	—	—	1
PT206	PULLER, MANUAL 2 JAW - 5 TON	1	1	1	1	1	1
PT204	PULLER, MANUAL 2 JAW - 2 TON	—	—	1	—	1	1
PT203	PULLER, MANUAL 2 JAW - 2 TON	—	—	—	—	—	1
PT202	PULLER, MANUAL 2 JAW - 1 TON	—	—	—	—	—	1
PT116	PULLER, MANUAL 3 JAW - 36 TON	—	—	—	—	—	1
PT113	PULLER, MANUAL 3 JAW - 327 TON	—	—	—	—	—	1
PT110	PULLER, MANUAL 3 JAW - 18 TON	1	1	—	1	1	1
PT108	PULLER, MANUAL 3 JAW - 15 TON	—	—	—	—	—	1
PT106	PULLER, MANUAL 3 JAW - 9 TON	1	1	1	1	1	1
PT104	PULLER, MANUAL 3 JAW - 4.5 TON	1	—	1	1	1	1
PT103	PULLER, MANUAL 3 JAW - 2 TON	—	—	—	1	—	1
PT102	PULLER, MANUAL 3 JAW - 1 TON	—	—	—	—	—	1
2008508	TOOL BOARD KIT, POSI LOCK TOOL SETS	1	1	1	1	2	2

Model Shown:

**PTPMW-1**

1 to 2 Metric Ton Puller Set



Model Shown:

**PTTK-107**

4-in-1 Puller Set



Model Shown:

**PTTB-1045**

Internal/External  
Slide Hammer Puller Set



**Features**

**THESE PULLER SETS ARE ESSENTIAL IN REMOVING INTERNAL PILOT BEARINGS, BEARING CUPS, BUSHINGS, SEALS ALONG WITH EXTERNAL BEARINGS, BEARING RACES, PULLEYS, AND MANY OTHER PRESS-FIT ITEMS FROM ONE COMPACT SET.**

Description	Qty	Number of Jaws	Capacity Tons (kN)	Reach in. (mm)
PT102 Puller	1	3	1 ton (9 kN)	2.25 (57)
PT202 Puller	1	2	1 ton (9 kN)	2.25 (57)
PT103 Puller	1	3	2 tons (18 kN)	3 (76.2)
PT203 Puller	1	2	2 tons (18 kN)	3 (76.2)
Case	1	12" x 17" x 5" (8 lbs.) 305 x 432 x 127 mm (3.6 kg)		
Optional				
PTPMW	Tool board set 16"x26" (406x660 mm)			

Description	Dimensions	Part #
Manual Puller	—	PT107
Tip Protector	—	PTP4
Internal Puller Jaws	—	PT10554
Slide Rod	—	PT10561
Slide Hammer	2.5 lb. (1.13 kg)	PT10562
Internal Puller Long Jaw (3)	—	PT10554L
Case	34" x 8.5" x 4.5" (15.8 lbs.) 864 x 216 x 114 mm (7.2 kg)	—
Optional Accessories		
Slide Hammer	5 lb. (2.27 kg)	PT10563
Small Hub Collar	0" to 1.5" (0 to 38 mm)	PTHP-30
Large Hub Collar	0" to 2" (0 to 51 mm)	PTHP-40
Extra Large Hub Collar	0" to 3" (0 to 76 mm)	PTHP-50
Tip Reducer/Extender	—	PTHP-70
Bolt Extender	—	PTX4
Transmission Jaw	—	PT10454T

Description	Dimensions	Part #
Manual Puller	—	PT107
Internal Puller	—	PT105
Tip Protector	—	PTP4
Slide Rod	—	PT10561
Slide Hammer	2.5 lb. (1.13 kg)	PT10562
Internal Puller Long Jaw (3)	—	PT10554L
Case	24" x 16.5" x 4.5" (18.3 lbs.) 610 x 419 x 114 mm (8.3 kg)	—
Optional Accessories		
Slide Hammer	5 lb. (2.27 kg)	PT10563
Small Hub Collar	0" to 1.5" (0 to 38 mm)	PTHP-30
Large Hub Collar	0" to 2" (0 to 51 mm)	PTHP-40
Extra Large Hub Collar	0" to 3" (0 to 76 mm)	PTHP-50
Tip Reducer/Extender	—	PTHP-70
Bolt Extender	—	PTX4
Transmission Jaw	—	PT10454T

Model Shown:  
**PTHP-1**



**SIMPLIFY THE REMOVAL OF MANY INDUSTRIAL AND AUTOMOTIVE FANS AND BLOWER WHEELS BY PROVIDING A SOLID CONNECTION BETWEEN THE PULLER AND FAN HUB.**

► **Includes**

Description	Dimensions	Part #
Small Collar Adaptor	0" to 1.5" (0 to 38 mm)	PTHP-30
Large Collar Adaptor	0" to 2" (0 to 51 mm)	PTHP-40
Tip Reducer/Extender	—	PTHP-70
Square Head Set Screws (4)	—	PTHP-60
Optional Accessories		
Extra Large Hub Collar	0" to 3" (0 to 76 mm)	PTHP-50

Model Shown:  
**PTHP-2**

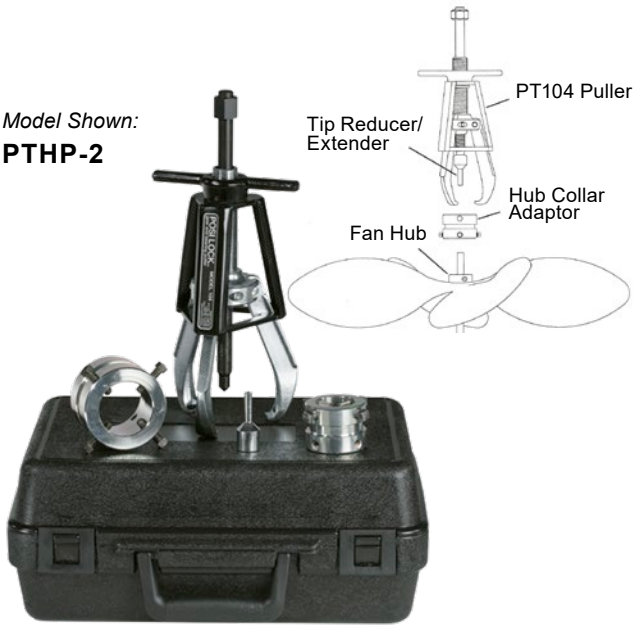

► **Includes**

Description	Dimensions	Part #
Manual Puller	—	PT104
Small Collar Adaptor	0" to 1.5" (0 to 38 mm)	PTHP-30
Large Collar Adaptor	0" to 2" (0 to 51 mm)	PTHP-40
Tip Reducer/Extender	—	PTHP-70
Square Head Set Screws (4)	—	PTHP-60
Case	13" x 9.5" x 5.5" (9 lbs.) 330 x 241 x 140 mm (4.1 kg)	—
Optional Accessories		
Extra Large Hub Collar	0" to 3" (0 to 76 mm)	PTHP-50

Model Shown:  
**PTFR-104K**  
Fan Removal Adaptor Kit  
for Wind Turbines



► **Includes**

Description	Part #
Manual Puller	PT104
Fan Removal Adaptor	PTFR104
Fan Puller Tip Reducer	PTX4F
Fan Removal Hub Screws (5)	PTFR-60
Case	—

Model Shown:  
**PTPHB-116,**  
**PTPHB-110**



**Features**

**KNOWN FOR SAFETY, DURABILITY, AND EASE OF USE, POSI LOCK PULLERS ARE DESIGNED TO HELP EXTEND BEARING LIFE IN APPLICATIONS THROUGH PROPER INSTALLATION, REMOVAL, AND SERVICE.**

- 4,5 to 45-ton capacity puller with up to 14" (356 mm) reach and 25" (635 mm) spread for large pulling requirements
- 10,000 PSI (690 Bar) single-acting cylinder that allows for high tonnage repeatable execution
- Slim tapered heat-treated tips allow for better gripping and easier access in tight spots



**Puller Accessories**

Power Team offers accessories to compliment your puller. These accessories conveniently store, transport and position your hydraulic pullers to maximize your productivity.



Order No.	Puller No. *
Storage Transport Cart	
PTPT-2550	PTPHB-213
PTPT-2550	PTPHB-113
PTPT-2550	PTPHB-116

**Ordering Information**

2 Jaw		3 Jaw		Cap. Short Tons	Cylinder Included	Reach in. (mm)	Spread in. (mm)	Long Jaw/Extra Long Jaw	
Standard Jaw Order No.	Standard Jaw Order No.	Long Jaw/ XL Jaw Order No.	Long Jaw/ XL Jaw Order No.					Reach In. (mm)	Spread In. (mm)
PTPHB-206E	PTPHB-106E	4,5	C55C	6 (152)	.5 to 8 (13 to 203)	---	---	-	-
PTPHB-208E	PTPHB-108E	9	C106C	8 (203)	.75 to 12 (19 to 305)	PTPHB-208LE PTPHB-208XLE	PTPHB-108LE PTPHB-108XLE	9.8 (249) 16 (406)	15.8 (401) 22 (559)
PTPHB-210E	PTPHB-110E	14	C1510C	9.67 (245)	1 to 15 (25 to 38)	PTPHB-210LE	PTPHB-110LE	16 (406)	22 (559)
PTPHB-213E	PTPHB-113E	23	C2514C	12 (305)	2.5 to 18 (64 to 457)	PTPHB-213LE	PTPHB-113LE	20 (508)	30 (762)
---	PTPHB-116E	45	C5513C	14 (356)	3 to 25 (76 to 635)	---	PTPHB-116LE	26 (660)	38 (965)



Model Shown:  
**PTPHC-110**



**THESE HYDRAULIC PULLERS DESIGNED TO HANDLE REMOVING JOBS WITH A MINIMAL AMOUNT OF EFFORT FOR THE ULTIMATE EFFICIENT PULLING SOLUTION.**

- 4,5 to 45-ton capacity puller with up to 14" (356 mm) reach and 25" (635 mm) spread for large pulling requirements
- Lightweight, two-speed manually operated 10,000 PSI (690 Bar) hydraulic pump provides high oil volume for fast cylinder piston approach, then the pump automatically shifts to the high-pressure stage to move the load
- 10,000 PSI (690 Bar) single-acting cylinder that allows for high tonnage repeatable execution

**i Puller Accessories**

Power Team offers accessories to compliment your puller. These accessories conveniently store, transport and position your hydraulic pullers to maximize your productivity.



Order No.	Puller No. *
PTPT-2550	PTPHC-213
PTPT-2550	PTPHC-113
PTPT-2550	PTPHC-116

**i Included with the Kits\***

- Puller Iron and Ram Point Set
- Hydraulic Cylinder
- Lift and Positioning Plate
- Two Speed Manually operated Pump
- Gauge Adapter, 10,000 PSI (690 Bar) Gauge
- 10' (3.05 m) heavy-duty Hose
- Male Coupler with dust cap

**Ordering Information**

2 Jaw		3 Jaw								
Standard Jaw Order No.	Standard Jaw Order No.	Cap. Short Tons	Cylinder Included	Pump Included	Reach in. (mm)	Spread in. (mm)	Long Jaw/Extra Long Jaw			
							2 Jaw	3 Jaw	Dimensions	
							Long Jaw/ XL Jaw Order No.	Long Jaw/ XL Jaw Order No.	Reach In. (mm)	Spread In. (mm)
PTPHC-206E	PTPHC-106E	4,5	C55C	P19L	6 (152)	.5 to 8 (13 to 203)	---	---	-	-
PTPHC-208E	PTPHC-108E	9	C106C	P19L	8 (203)	.75 to 12 (19 to 305)	PTPHC-208LE PTPHC-208XLE	PTPHC-108LE PTPHC-108XLE	9.8 (249) 16 (406)	15.8 (401) 22 (559)
PTPHC-210E	PTPHC-110E	14	C1510C	P59L	9.67 (245)	1 to 15 (25 to 38)	PTPHC-210LE	PTPHC-110LE	16 (406)	22 (559)
PTPHC-213E	PTPHC-113E	23	C2514C	P159	12 (305)	2.5 to 18 (64 to 457)	PTPHC-213LE	PTPHC-113LE	20 (508)	30 (762)
---	PTPHC-116E	45	C5513C	P460	14 (356)	3 to 25 (76 to 635)	---	PTPHC-116LE	26 (660)	38 (965)



Pullers

Model Shown:  
**PTPHD-110**



**Features**

**4,5 TO 45-TON CAPACITY HYDRAULIC PULLERS KITS ARE AVAILABLE IN 2- OR 3-JAW MODELS AND OFFER MANY OPTIONS FOR FLEXIBILITY WITH ANY PROJECT.**

- 4,5 to 45-ton capacity puller with up to 14" (356 mm) reach and 25" (635 mm) spread for large pulling requirements
- PE17 Series lightweight, 10,000 PSI (690 Bar) heavy-duty electric pump for reliable performance use after use
- 10,000 PSI (690 Bar) single-acting cylinder that allows for high tonnage repeatable execution



**Puller Accessories**

Power Team offers accessories to compliment your puller. These accessories conveniently store, transport and position your hydraulic pullers to maximize your productivity.



Order No.	Puller No. *
<b>Storage Transport Cart</b>	
PTPT-2550	PTPHD-213
PTPT-2550	PTPHD-113
PTPT-2550	PTPHD-116



**Included with the Kits\***

- Puller Iron and Ram Point Set
- Hydraulic Cylinder
- Lift and Positioning Plate
- 2 Stage Electric Pump
- Gauge Adapter, 10,000 PSI (690 Bar) Gauge
- 10' heavy-duty Hydraulic Hose
- Male Coupler with dust cap

**Ordering Information**

2 Jaw		3 Jaw		Cap. Short Tons	Cylinder Included	Pump Included	Reach in. (mm)	Spread in. (mm)	Long Jaw/Extra Long Jaw	
Standard Jaw Order No.*	Standard Jaw Order No.*	2 Jaw	3 Jaw						Dimensions	
		Long Jaw/ XL Jaw Order No.*	Long Jaw/ XL Jaw Order No.*	Reach In. (mm)	Spread In. (mm)					
PTPHD-206-E220	PTPHD-106-E220	---	---	4,5	C55C	PE172-E220	6 (152)	.5 to 8 (13 to 203)	-	-
PTPHD-208-E220	PTPHD-108-E220	PTPHD-208L-E220 PTPHD-208XL-E220	PTPHD-108L-E220 PTPHD-108XL-E220	9	C106C	PE172-E220	8 (203)	.75 to 12 (19 to 305)	9.8 (249) 16 (406)	15.8 (401) 22 (559)
PTPHD-210-E220	PTPHD-110-E220	PTPHD-210L-E220	PTPHD-110L-E220	14	C1510C	PE172-E220	9.67 (245)	1 to 15 (25 to 38)	16 (406)	22 (559)
PTPHD-213-E220	PTPHD-113-E220	PTPHD-213L-E220	PTPHD-113L-E220	23	C2514C	PE172-E220	12 (305)	2.5 to 18 (64 to 457)	20 (508)	30 (762)
---	PTPHD-116-E220	---	PTPHD-116L-E220	45	C5513C	PE172-E220	14 (356)	3 to 25 (76 to 635)	26 (660)	38 (965)



\*Standard models supplied with 220v 50hz pump. For other voltage options, please contact technical support.

Model Shown:

**PTPH-50T**

Shown with long jaws



**Features**

**FOR THOSE BIG JOBS, THIS 45-TON PULLER SET IS WHAT YOU NEED. JUST THINK OF THE JOBS YOU CAN DO WITH THIS PULLER WITH THE INCLUDED EASY TO MANEUVER CART THAT RAISES TO A HEIGHT OF 55" (1397 MM).**

- 45-ton capacity puller with 14" (356 mm) reach and 25" (635 mm) spread for large pulling requirements
- PE17 Series lightweight, two-stage, 10,000 PSI (690 Bar) heavy-duty electric pump for reliable performance use after use
- Remote jog switch with a 10' (3 m) cords allows for additional worker safety
- 10,000 PSI (690 Bar) single-acting cylinder that allows for high tonnage repeatable execution
- Flexible mounting platform allows puller to swivel 360 degrees for easy accessibility to any project



**Included with the 45 Ton Pullers**

- 45-ton puller, model PTPH-116
- Standard and long jaw sets
- Ram Point Set
- PTC-50T cart
- 45-Ton Hydraulic cylinder
- 10,000 PSI (690 Bar) electric two-stage pump, remote jog switch on electric pump with 10' cord (3.05 m)
- 10' (3.05 m) hose
- Gauge, coupler
- Lift and Positioning Plate
- 6" (152 mm) and 12" (305 mm) ram extenders



**Hydraulic Puller Suggestion For Selection**



The maximum force exerted in tons should be 7 to 10 times the diameter of the shaft in inches; for example, a 1.5" (38 mm) diameter shaft would generally require a 14-ton puller.

**Ordering Information**

Model Number*	Capacity Tons	Number of Jaws	Reach	Spread	Weight of Set**	Long Jaws		
	Tons (kN)		in. (mm)	in. (mm)		Part Number	Reach in. (mm)	Spread in. (mm)
PTPH-50T	45 tons (445 kN)	3	14 in. (356 mm)	3 to 25 in. (76 to 635 mm)	320 lbs (145 kg)	PTPH-11654L	26 in. (660 mm)	2 to 38 in. (51 to 965 mm)

\*Standard models supplied with 115v 50/60hz pump. For other voltage options, please contact technical support.

\*\*Weight does not include hydraulic components due to variances in weight.

Model Shown:  
**PTPH-100T**



**Features**

**91 METRIC TON HYDRAULIC PULLERS PROVIDE MAXIMUM EXTRACTION FORCE IN APPLICATIONS REQUIRING HIGH FORCE REMOVAL OF LARGE PRESS FIT PARTS.**

- 91-ton capacity puller with 50" (1270 mm) reach and 70" (1778 mm) spread for extra-large pulling requirements
- Hydraulic-actuated lift cart extends vertically up to 5' (1.52 m) to align easily with project
- Lifting brackets allow the puller to be removed from the cart and lifted into workplaces
- PE55 Series lightweight, two-stage 10,000 PSI (690 Bar) heavy-duty electric pump for reliable performance use after use
- 10,000 PSI (690 Bar) single-acting 10.25" (260 mm) stroke cylinder with spring return for ease of compression and retraction. (Optional double-acting cylinder available)
- Available in 2-jaw, vertical 2-jaw, 3-jaw, or 2/3-jaw combination to allow a wide range of flexibility with any project



Vertical 91-Ton Hydraulic Puller | PTPH-102TV

The 91- Metric Ton vertical hydraulic puller was designed for big pulling jobs with limited jaw placement options. This two-jaw vertical puller is available with a single or double acting cylinder. This versatile puller can also be used in a suspended position.



**PosiLock Safety Insight**

The PTPH-123T combination 91-ton puller transforms from a 2-jaw to a 3-jaw puller in 4 easy steps.

Lifting eyes can be used to lift puller off cart

Adjustable jaw guide

Adjustable jaw tips

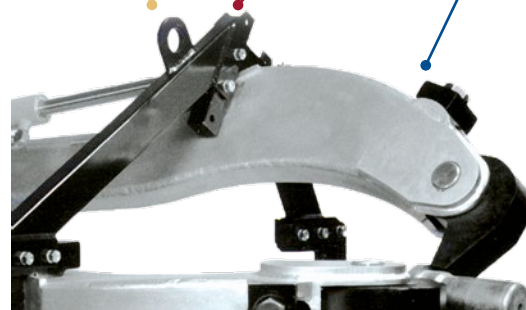



**Included with the 100 Ton Pullers**

- PE55 electric two-stage pump, 10,000 PSI (690 Bar)
- 91-ton cylinder 10,000 PSI (690 Bar), single acting with return spring 10.25" (260 mm) stroke (Optional double-acting cylinder available)
- Remote jog switch with 10' cord (3.05 m)
- Hydraulic-actuated lift cart extends puller from ground to a height of 5' (1.52 m)
- Multiple pushing adaptors
  - 1 - 3.5" diameter x 9" (89 x 229 mm)
  - 1 - 3.5" diameter x 19" (89 x 483 mm)
  - 1 - 3.5" diameter x 29" (89 x 737 mm)
  - 1 - Coupler
- Adjustable jaw tips and guides (Custom jaw tips available)

**Technical Information**

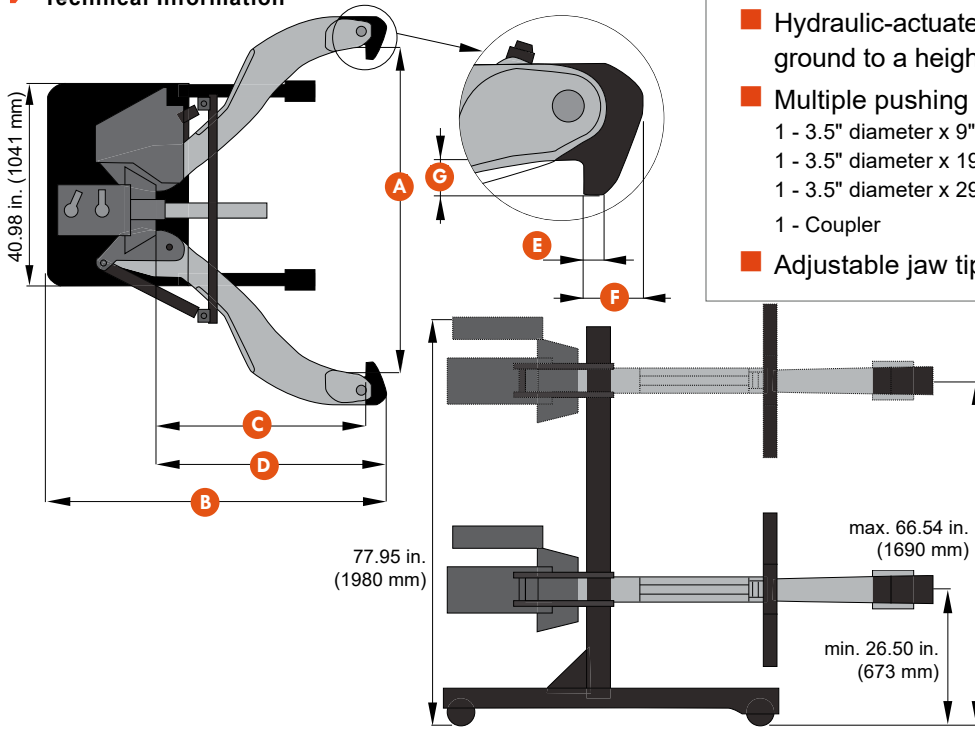

**Ordering Information**

Model Number*	Capacity Tons (kN)	Number of Jaws	Dimensions							Weight lbs. (kg)
			Spread A	Overall Length B	Reach C	Jaw Length D	Jaw Tip Width E	Tip Clearance F	Tip Depth G	
			in. (mm)	in. (mm)	in. (mm)	in. (mm)	in. (mm)	in. (mm)	in. (mm)	
<b>Single Acting</b>										
PTPH-102T-E220	91 tons (890 kN)	2	7.5 to 70 in. (191 to 1778 mm)	77 in. (1956 mm)	50 in. (1270 mm)	53 in. (1346 mm)	1.25 in. (32 mm)	3.5 in. (89 mm)	3.5 in. (89 mm)	1700 lbs. (771 kg)
PTPH-100T-E220	91 tons (890 kN)	3	7.5 to 70 in. (191 to 1778 mm)	77 in. (1956 mm)	50 in. (1270 mm)	53 in. (1346 mm)	1.25 in. (32 mm)	3.5 in. (89 mm)	3.5 in. (89 mm)	1950 lbs. (885 kg)
PTPH-123T-E220	91 tons (890 kN)	2/3	7.5 to 70 in. (191 to 1778 mm)	77 in. (1956 mm)	50 in. (1270 mm)	53 in. (1346 mm)	1.25 in. (32 mm)	3.5 in. (89 mm)	3.5 in. (89 mm)	2000 lbs. (907 kg)
<b>Single Acting Vertical</b>										
PTPH-102TV-E220	91 tons (890 kN)	2	7.5 to 70 in. (191 to 1778 mm)	77 in. (1956 mm)	50 in. (1270 mm)	53 in. (1346 mm)	1.25 in. (32 mm)	3.5 in. (89 mm)	3.5 in. (89 mm)	1800 lbs. (816 kg)
<b>Double Acting</b>										
PTPH-102TDA-E220	91 tons (890 kN)	2	7.5 to 70 in. (191 to 1778 mm)	77 in. (1956 mm)	50 in. (1270 mm)	53 in. (1346 mm)	1.25 in. (32 mm)	3.5 in. (89 mm)	3.5 in. (89 mm)	1800 lbs. (816 kg)
PTPH-100TDA-E220	91 tons (890 kN)	3	7.5 to 70 in. (191 to 1778 mm)	77 in. (1956 mm)	50 in. (1270 mm)	53 in. (1346 mm)	1.25 in. (32 mm)	3.5 in. (89 mm)	3.5 in. (89 mm)	2050 lbs. (930 kg)
PTPH-123TDA-E220	91 tons (890 kN)	2/3	7.5 to 70 in. (191 to 1778 mm)	77 in. (1956 mm)	50 in. (1270 mm)	53 in. (1346 mm)	1.25 in. (32 mm)	3.5 in. (89 mm)	3.5 in. (89 mm)	2100 lbs. (953 kg)
<b>Double Acting Vertical</b>										
PTPH-102DATV-E220	91 tons (890 kN)	2	7.5 to 70 in. (191 to 1778 mm)	77 in. (1956 mm)	50 in. (1270 mm)	53 in. (1346 mm)	1.25 in. (32 mm)	3.5 in. (89 mm)	3.5 in. (89 mm)	1800 lbs. (816 kg)

\*Standard models supplied with 220v 50hz pump. For other voltage options, please contact technical support.

Model Shown:  
**PTPH-200T**



**Features**

**PROVIDES ULTIMATE HYDRAULIC PULLER MUSCLE FOR THE REMOVAL OF STUBBORN GEARS, BEARINGS, AND WHEELS FROM HEAVY MINING, RAILROAD, AND CONSTRUCTION MACHINERY.**

- 181-ton capacity puller with 48" (1219 mm) reach and 70" (1778 mm) spread for extra-large pulling requirements
- PE55 Series lightweight, two-stage 10,000 PSI (690 Bar) heavy-duty electric pump for reliable performance use after use
- 10,000 PSI (690 Bar) double-acting 13.25" (337 mm) stroke cylinder for ease of compression and retraction
- Hydraulic-actuated lift cart extends vertically up to 5' (1.52 m) to align easily with project
- Remote jog switch with a 10' (3m) cords allows for additional worker safety



**Hydraulic Puller Suggestion For Selection**



The maximum force exerted in tons should be 7 to 10 times the diameter of the shaft in inches; for example, a 1.5" (38 mm) diameter shaft would generally require a 15-ton puller.

▶ 181 Ton cylinder used in this pulling application.



► **Technical Information**

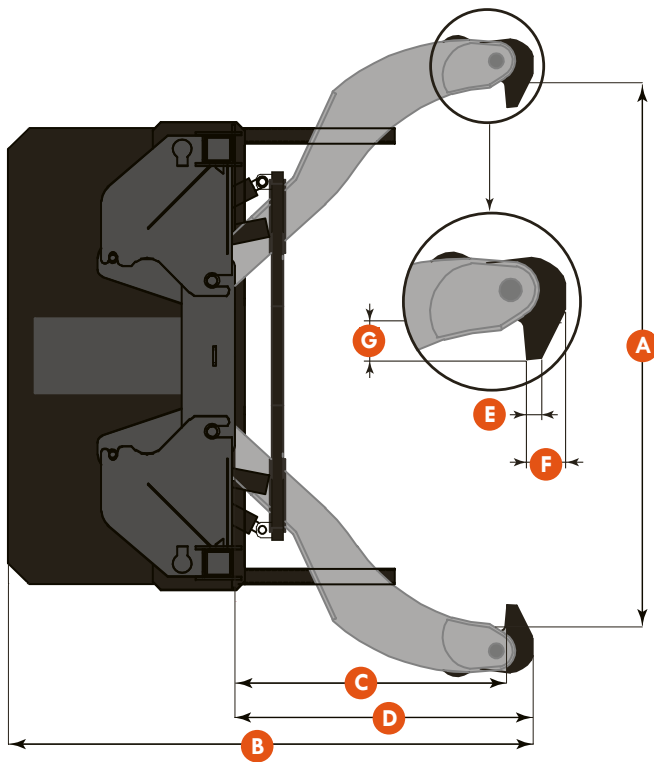
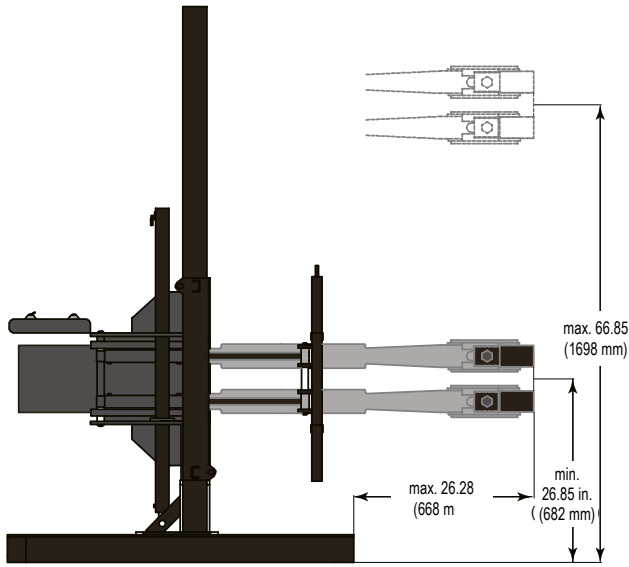

**Included with the 200 Ton Pullers**

- PE55 electric two-stage pump, 10,000 PSI (690 Bar)
- 181-ton cylinder 10,000 PSI (690 Bar), double acting 13.25" (337 mm) stroke
- Remote jog switch with 10' cord (3.05 m)
- Hydraulic-actuated lift cart extends puller from ground to a height of 5' (1.52 m)
- Jaws are hydraulically controlled with cylinders
- Multiple pushing adaptors
  - 1 - 4" diameter x 9" (102 x 229 mm)
  - 1 - 4" diameter x 19" (102 x 483 mm)
  - 1 - 4" diameter x 29" (102 x 737 mm)
  - 1 - 4" diameter x 39" (102 x 990 mm)
- Adjustable jaw tips and guides (Custom jaw tips available)

**Optional Jaw Tips**

All jaws are 3 in. (76 mm) thick.

\*PTHT-1180 tips come standard with all 100 and 181-ton pullers.

- PTHT-1180S**
- PTHT-1180A**
- PTHT-1180\***

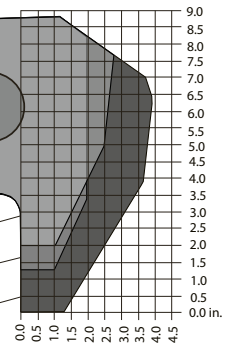

► **Ordering Information**

Model Number*	Capacity	Number of Jaws	Dimensions							Weight
			Spread	Overall Length	Reach	Jaw Length	Jaw Tip Width	Tip Clearance	Tip Depth	
			<b>A</b>	<b>B</b>	<b>C</b>	<b>D</b>	<b>E</b>	<b>F</b>	<b>G</b>	
	Tons (kN)		in. (mm)	in. (mm)	in. (mm)	in. (mm)	in. (mm)	in. (mm)	in. (mm)	lbs. (kg)
<b>PTPH-200T-E220</b>	181 tons (1779 kN)	4	8 to 70 in. (203 to 1778 mm)	78.5 in. (1994 mm)	48 in. (1219 mm)	53 in. (1346 mm)	1.25 in. (32 mm)	3.5 in. (89 mm)	3.5 in. (89 mm)	4150 lbs. (1882 kg)

\*Standard models supplied with 220v 50hz pump. For other voltage options, please contact technical support.

Model Shown:  
**PTPHS-108,**  
**PTPHS-208**



**Features**

**THESE POWERFUL, SELF-CONTAINED PULLING SYSTEMS ARE IDEAL FOR PULLING A WIDE VARIETY OF PRESS-FIT PARTS, INCLUDING BEARINGS, GEARS, BUSHINGS, WHEELS, AND PULLEYS. YOU GET THE EASE OF A MANUAL PULLER WITH THE POWER OF HYDRAULICS.**

- 108 or 208 puller assembly with standard length jaws with a reach up to 8" (203 mm) and a 12" (305 mm) spread
- Self-contained pump/cylinder with swiveling adjustable-length pump handle for ease of use at any angle
- Multiple extension rod parts that includes a 1.9" (48 mm) and two 2.9" (74 mm) extension rods with centering tips for versatility with any project
- T-handle facilitates the opening, closing, locking, and aligning of the jaws for easy operation
- Safety cage guides jaws for quick setup, providing a "vise-like" grip reducing slippage

**Long Jaws**

When ordering optional long jaws, extension rods should also be ordered to extend length of ram.

**Ordering Information**

2 Jaw		3 Jaw		Cap. Metric Tons	Jaw	Reach in. (mm)	Spread in. (mm)	Long Jaw/Extra Long Jaw	
Standard Jaw Order No.	Standard Jaw Order No.	2 Jaw	3 Jaw					Dimensions	Dimensions
Standard Jaw Order No.	Standard Jaw Order No.	Long Jaw/ XL Jaw Order No.	Long Jaw/ XL Jaw Order No.	Reach In. (mm)	Spread In. (mm)	PTPHS-208L PTPHS-208XL	PTPHS-108L PTPHS-108XL	Reach In. (mm)	Spread In. (mm)
PTPHS-208	PTPHS-108	11	10854	8 (203)	.75 to 12 (19 to 305)	PTPHS-208L PTPHS-208XL	PTPHS-108L PTPHS-108XL	9.8 (249) 16 (406)	15.8 (401) 22 (559)



Model Shown:

**PTPH-1131E (Internal/External)**



**INTERNAL/EXTERNAL PULLING MADE EASY. FUNCTIONS WITH A PTPHB, PTPHC, AND PTPHD HYDRAULIC 4,5 TO 45-TON CAPACITY PULLERS TO ALLOW THE FLEXIBILITY OF INTERNAL OR EXTERNAL PULLING.**

- External pulling up to 20" (508 mm) reach and 30" (762 mm) spread for large pulling requirements
- Internal pulling up to 7" (178 mm) reach and 21" (533 mm) spread for an effective range of internal pulling capabilities
- Safety cage houses either the internal or external jaws by simply removing the ball lock pins that allows you to change from internal to external in seconds
- Slim tapered heat-treated tips permit better gripping and easier access in tight spots

**Ordering Information**

Order No.	Number of Jaws	Part Number	Jaw Style	Reach in. (mm)	Spread in. (mm)	Overall Length in. (mm)	Jaw Width in. (mm)	Jaw Length in. (mm)
PTPH-1131E	3	11354T	Internal	7 (178)	8 to 21 (203 to 533)	25.75 (654)	1.25 (32)	10.9 (277)
	3	11354	External	12 (305)	2.5 to 18 (64 to 457)	27 (686)	1.25 (32)	13.7 (348)
OPTIONAL	3	11354L	External Long	20 (508)	1.5 to 30 (38 to 762)	36 (914)	1.25 (32)	21.6 (549)

Model Shown:  
**1024**

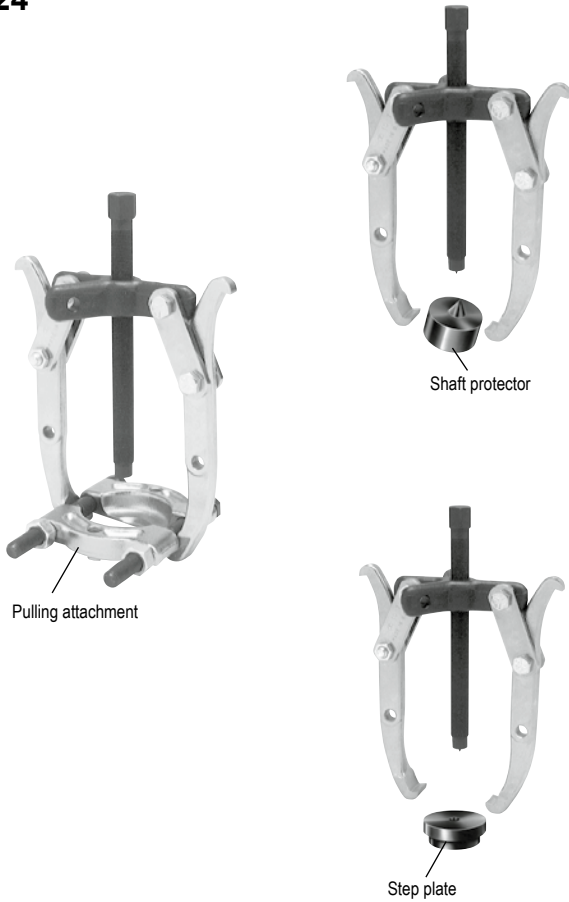

**Features**

**VERSATILE DESIGN OFFER A TIGHT GRIP FOR YOUR PULLING APPLICATIONS.**

- Lock-Jaw™ feature on all pullers. The harder the pull, the tighter the grip for removing gears, bearings and countless other press fitted parts.
- 2-way, 3-way and 2/3-way combination pullers make it easy to select a specific puller for your application.
- Forged from high quality steel, heat treated and subjected to rigorous tests which exceed rated puller capacity.
- Forcing screw threads are rolled, not cut, creating a smoother and stronger thread.
- Heat treated alloy steel cross bolts for maximum shear strength.
- Machined puller jaw toes produce larger and stronger pulling toes.
- Meets Fed. Spec.: GGG-P-00781-D

**Two-jaw head puller example**

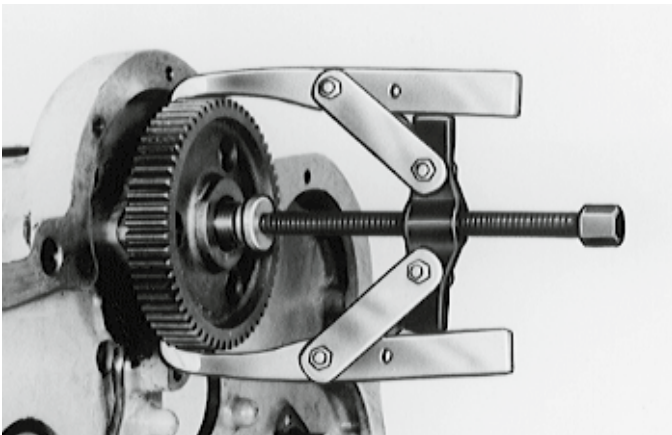

**Choosing the right size puller**



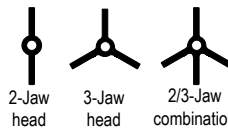

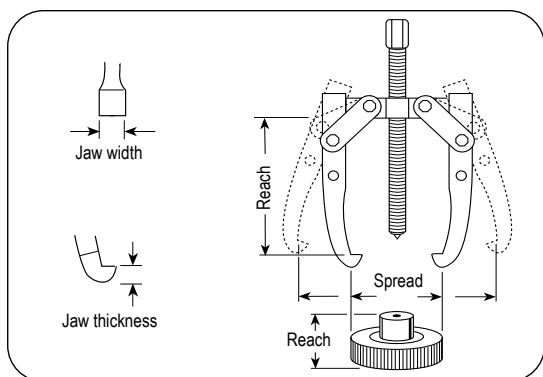

Styles of puller cross heads

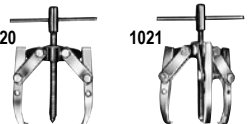

Compare the "reach" and "spread" of the pulling job with that of the pullers listed. The puller selected must have dimensions greater than those of the job.

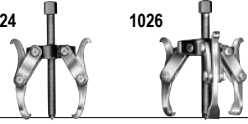
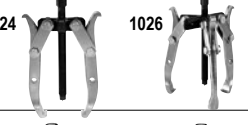
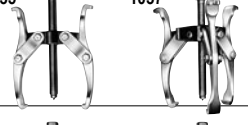
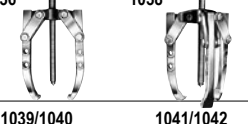

► **Ordering Information**

	Order No.	Cap. (tons)	Jaw Type	Max.		Jaw		Screw Size (in.)	Weight (kg)
				Reach (mm)	Spread (mm)	Thickness (mm)	Width (mm)		
	1020	1	2-Jaw	54,0	82,6	3,6	6,4	5/16 - 24 x 98,4 mm	0,14
	1021		3-Jaw	54,0	82,6				
	1023	2	2/3-Jaw *	85,7	120,7	Upper 4,8 Lower 3,2	Upper 6,4 Lower 12,7	3/8 - 24 x 124 mm	0,40
	1024	5	2/3-Jaw *	82,6	152,4	Upper 23,8 Lower 6,4	Upper 9,5 Lower 19,1	9/16 - 20 x 178 mm	0,43
	1026		2/3-Jaw *	82,6	177,8				
	1025	5	Long 2-Jaw *	139,7	152,4	Upper 23,8 Lower 6,4	Upper 9,5 Lower 19,1	9/16 - 20 x 178 mm	0,19
	1027		Long 2/3-Jaw *	139,7	177,8				1,65
	1035	7	2-Jaw *	127,0	228,6	Upper 7,9 Lower 8,7	Upper 25,4 Lower 25,4	11/16 - 18 x 229 mm	2,04
	1037		2/3-Jaw *	127,0	266,7				2,78
	1036	7	Long 2-Jaw	222,3	241,3	8,7	25,4	11/16 - 18 x 229 mm	2,44
	1038		Long 2/3-Jaw	222,3	279,4				3,69
	1039	13	2-Jaw	279,4	304,8	14,3	25,4	13/16 - 16 x 305 mm	4,90
	1040		Long 2-Jaw	387,4	393,7				5,90
	1041		2/3-Jaw	279,4	304,8				7,37
	1042		Long 2/3-Jaw	387,4	431,8				8,50
	1044	17.5	Long 2-Jaw	476,3	406,4	20,6	32,5	1 - 14 x 343 mm	11,79
	1045		3-Jaw	368,3	355,6				14,97
	1046		Long 3-Jaw	476,3	406,4				16,78
	1050	25	Long 3-Jaw	565,2	508,0	27,0	38,1	1 1/4 - 12 x 422 mm	27,22

\* Reversible Jaws

Pullers

Model Shown:  
**927, 938, 939**



**Features**

**VERSATILE DESIGN OFFERS A TIGHT GRIP FOR YOUR PULLING APPLICATIONS.**

- Can apply a pushing or pulling force, depending on how the puller is set up.
- Optional leg kits adapt your Bi-Directional™ Puller to extra long or extra short reach.
- A wide variety of threaded adapters, bearing pulling attachments and internal pulling attachments can be used in combination with our Bi-Directional™ Puller.
- Meets Fed. Spec.: GGG-P-00781-D



**Selection and Capacity Rating**

Each Bi-Directional™ Puller specified tonnage "capacity" is determined using its standard legs in tension. Using longer legs, or a setup in which the legs are in compression, will reduce the "capacity." Always select the largest "capacity" puller and the shortest legs that will fit the job.



**Puller Adapters**



Male/Female

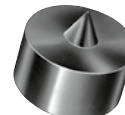

Shaft Protector

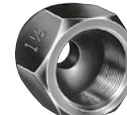

Female



Step Plate

For more information, see page 240.

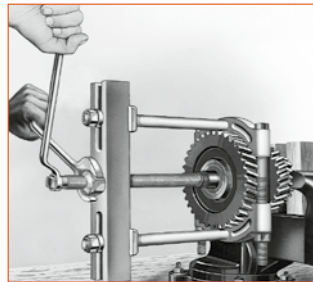
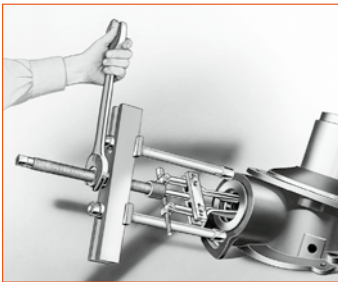

**ASSEMBLING THE TOOL TO APPLY PUSHING OR PULLING FORCE:**

1. Determine if you want the tool's forcing screw to push or pull.
2. To exert pushing force, the forcing nut is installed beneath the cross block, as shown on left.
3. To cause the forcing screw to pull, the forcing nut is placed on top of the cross block.
4. The sliding plates must always be placed on the opposite side of the cross block from the forcing nut.

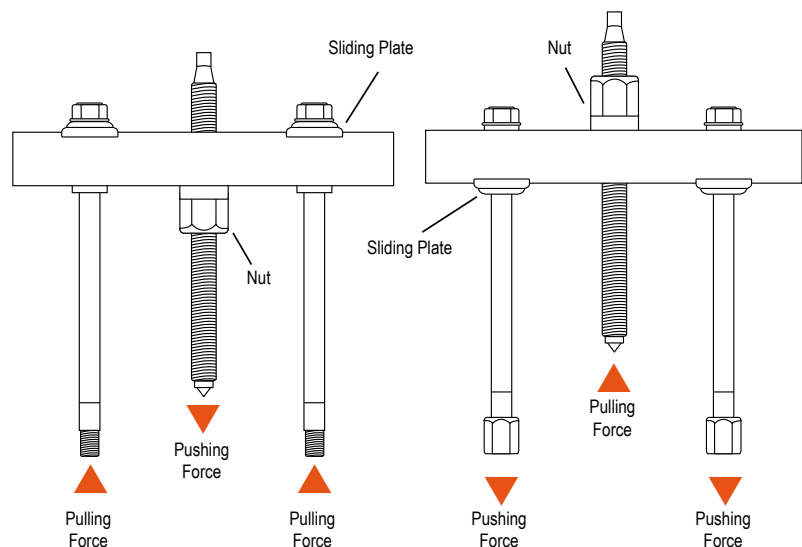

**Ordering Information**

**10 TON MECHANICAL BI-DIRECTIONAL™**

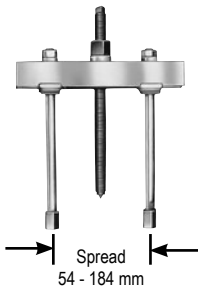

**9 Ton Capacity** can be used with 1123 bearing pulling attachment or 679 pulley pulling attachment. May also be used with 1150, 1151, 1152, or 1153 internal pulling attachments.

Order No.	Max.		Screw Size (in.)	Weight (kg)	Notes
	Reach (mm)	Spread (mm)			
927	210	54 - 184	3/4" - 16 x 305 mm	3,2	1/2" of forcing screw tip end is threaded 5/8"-18. 1100 legs and 24827 leg ends included.

**17.5 TON MECHANICAL BI-DIRECTIONAL™**

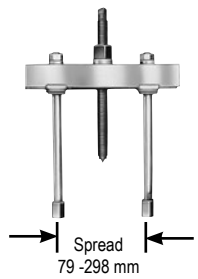

**16 Ton Capacity** can be used with 1124 and 1130 bearing pulling attachments or 679 and 680 pulley pulling attachments. May also be used with 1150, 1151, 1153, 1165, or 1166 internal pulling attachments.

Order No.	Max.		Screw Size (in.)	Weight (kg)	Notes
	Reach (mm)	Spread (mm)			
938	282	79 - 298	1"-14 x 336 mm	9,4	Leg ends threaded 5/8"-18. 1106 legs and 24827 leg ends included.

**30 TON MECHANICAL BI-DIRECTIONAL™**



**27 Ton Capacity** can be used with 1126 and 1127 bearing pulling attachments or 680 pulley pulling attachment (two 8012 adapters are required to connect 680 to puller). Can be used with 1165 internal pulling attachment.

Order No.	Max.		Screw Size (in.)	Weight (kg)	Notes
	Reach (mm)	Spread (mm)			
939	267	178 - 413	1 1/2" - 12 x 438 mm	20,0	Leg ends threaded 1"-14. 1109 legs and 28390 leg ends included.

**ACCESSORIES - PULLER LEGS**

	Order No.	Leg Length (mm)	Weight (kg)		Order No.	Leg Length (mm)	Weight (kg)		
927	1100	171 mm Legs	0,45		938	1104	419 mm Legs	3	
	1102	298 mm Legs	1			1105	572 mm Legs	4,1	
	1101	400 mm Legs	1,5			1108	762 mm Legs	5,2	
938	1107	114 mm Legs	1,1		939	1109	203 mm Legs	3,6	
	1106	241 mm Legs	2			1110	457 mm Legs	6,8	
						1111	711 mm Legs	10	

Pullers

**BLIND HOLE PULLER SET**

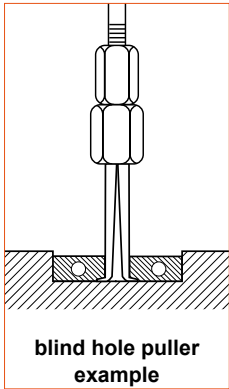

Removal of bearings, bushings, sleeves and other friction-fitted parts from blind holes can now be accomplished with ease. Set provides selection of expanding collets 8 to 44,5 mm I.D. Collet is placed through bore of part to be removed, then expanded with actuator pin so that lips of collet secure a positive grip for pulling. Pulling force is exerted by means of a forcing screw and bridge assembly or with a slide hammer. Equipped with a plastic case.

Order No.	Description
6981	Blind-hole puller set with slide hammer, forcing screw, bridge, actuator pins, collets, and storage box. Wt., 9,5 kg.

**CONTENTS OF 6981 SET**

Order No.	Description	Order No.	Description
24835	Forcing Screw	2009584	Slide Hammer Rod
24836	Forcing Screw Nut	41331	Bridge
22185	Hammer 1,1 kg.	—	Plastic Case - 508 × 381 × 140 mm
2009583	Pin Adapter and Thumb Screw		

Order No.	Description	Order No.	Description	Reach
2009585	Pin 3,5 mm	2009586	Collet 7,6 - 8,9 mm	38,1 mm
2009587	Pin 5,1 mm	2009588	Collet 8,9 - 11,1 mm	38,1 mm
2009589	Pin 7,1 mm	2009590	Collet 11,1 - 14,3 mm	44,5 mm
2009591	Pin 10,2 mm	2009592	Collet 14,3 - 22,0 mm	63,5 mm
2009593	Pin 12,7 mm	2009594	Collet 22,0 - 76,2 mm	76,2 mm

**SLIDE HAMMER PULLER SET**

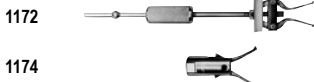

This very handy set is ideal for close-quarters, inside pulling jobs. The slide hammer puller set is very practical for pulling motor, generator, and magneto bearings. It's good for removing small-bore bushings, bearings, and oil seals.

Order No.	Description	Inch Range	
		Min. (mm)	Max. (mm)
SS2	Slide hammer puller set includes both 1172 and 1174. Wt., 2,6 kg.		
1172		12,7	50,8
1174		12,7	34,9

**SLIDE HAMMER PULLER SET**

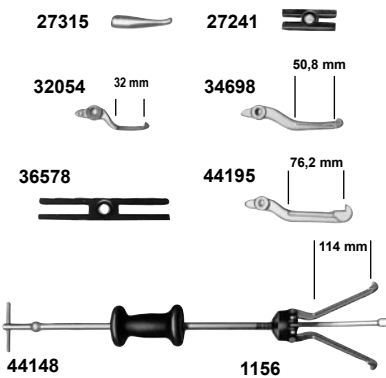

This useful set contains a reversible-jaw slide hammer puller with a 1,1 kg. sliding hammer plus an assortment of special jaws (3 of each size) and adapters. In this set, you get all the versatility you demand of a slide hammer puller.

Order No.	Description
1178	Slide hammer puller set with 1,1 kg. sliding hammer. Wt., 6,3 kg.

Jaw Order No.	2-Jaw Spread				3-Jaw Spread			
	Inside		Outside		Inside		Outside	
	Min. (mm)	Max. (mm)	Min. (mm)	Max. (mm)	Min. (mm)	Max. (mm)	Min. (mm)	Max. (mm)
44195	38,1	114,3	19,1	127	38,1	120,7	25,4	114
32054	19,1	60,3	—	—	25,4	69,9	—	—
44148	69,9	139,7	19,1	191	82,6	158,8	25,4	159
34698	31,8	88,9	25,4	114	38,1	108	38,1	114

**SLIDING HAMMERS ONLY**

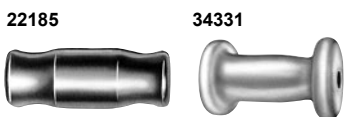

Order No.	Description
22185	1,1 kg. Sliding Hammer.
34331	2,3 kg. Sliding Hammer.

**BEARING CUP REMOVER**



The 7136 is perfect for pulling internal bearing cups, seals, bushings, etc. With a jaw spread of 23,8 to 82,6 mm, and reach to 88,9 mm. Use with any slide hammer having 5/8"-18 thread (1155, 1156 or 927 Bi-Directional™).

Order No.	Description
7136	Universal bearing cup remover. Wt., 0,7 kg.

**PILOT BEARING PULLERS**



1170

These very versatile pullers are built especially for inside pulling jobs, and particularly for removing flywheel pilot bearings on machines and construction vehicles. Also very practical for pulling motor, generator and magneto bearings.

Special slide hammer puller – Ideal for pulling jobs in very close quarters, as in removal of small-bore bushings, bearings, oil seals, etc. Internal pulling attachment has jaw spread of 12,7 to 35 mm. The handle end has a 1/2"– 20 thread.

Order No.	Description	Order No.	Reach (mm)	I.D. Spread		Weight (kg)
				Min. (mm)	Max. (mm)	
1170		1170	19,1	12,7	12,7	2,2
1173	Slide hammer puller. Wt., 1,6 Kg.	1171	25,4	22,2	54,0	2,2
1174	Puller head, less slide hammer. Wt., 0,4 Kg.	1172	44,5	12,7	50,8	2,2

**BASIC SLIDE HAMMER UNITS**



1155



1156

Compatible with internal pulling attachment and compatible with threaded adapters. 610 mm in length, 5/8"-18 threaded end.

Order No.	Description
1155	Basic slide hammer unit with 2,3 kg hammer. Wt., 3,3 kg.
1156	Basic slide hammer unit with 1,1 kg. hammer. Wt., 2,2 kg.

**REVERSIBLE-JAW SLIDE HAMMER PULLERS**



1176



1177

Ideal for pulling gears, bearings, outer races, grease retainers, oil seals, etc. Two or three jaws may be used and positioned for "inside" or "outside" pulling jobs. Both have 5/8"– 18 threaded end so attachments and adapters may be used.

Order No.	Description
1176	Slide hammer puller with 1,1 kg. hammer, 27241 two-way head and 34698 jaws.
1177	Slide hammer puller with 2,3 kg. hammer, 27241 two-way head and 34698 jaws.

Jaw Order No.	2-Jaw Spread				3-Jaw Spread				Length (mm)	Prod. Wt. (kg)
	Inside		Outside		Inside		Outside			
	Min. (mm)	Max. (mm)	Min. (mm)	Max. (mm)	Min. (mm)	Max. (mm)	Min. (mm)	Max. (mm)		
1176	31,8	88,9	25,4	114,0	38,1	108,0	38,1	114,0	686,0	3,6
1177	31,8	88,9	25,4	114,0	38,1	108,0	38,1	114,0	686,0	4,8

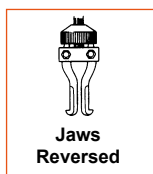

Pullers

Model Shown:

**PH303C, PH63C, HST11S, PH82K**



**Features**

**SELF CONTAINED PULLER SYSTEMS ENABLES FAST AND QUICK SETUP**

- Power Team pullers are tested for top performance and reliability at maximum capacity and jaw spread.
- Easily metered release valve control knob.
- Spring loaded live centering cone.
- Bladder type oil reservoir.
- Rapid adjustment.
- Use with 2 or 3-jaws.
- Supplied with a sturdy storage/carrying case.
- Features Power Team's exclusive PowerThon™ Limited Lifetime Warranty.

**HYDRA LOCK-JAW™ PULLING SYSTEM**

These pullers are ideal for pulling a wide variety of press-fitted parts including bushings, bearings, wheels, gears and pulleys. Hydra Lock-Jaw™ pullers have been rigorously tested for top performance and reliability. PH82K is a complete pulling system which includes a hydraulic power module, 2-way puller head, jaws, legs and bearing splitter attachment, all contained in a convenient carrying case.

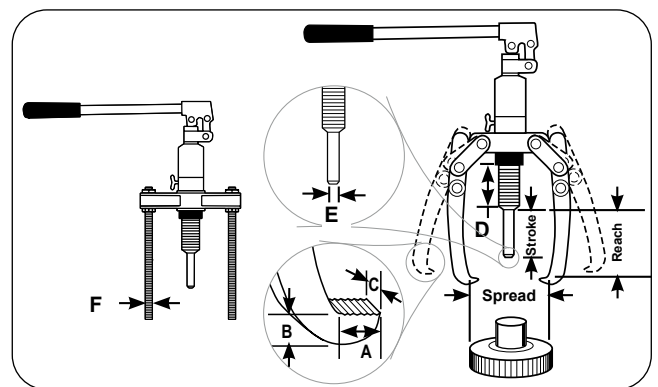

**Ordering Information**

Order No.	Cyl. Cap. (ton)	Reach Studs (mm)	Min. Jaws (mm)	Min. Reach (mm)	Max. Studs (mm)	Spread (mm)	Stroke (mm)	A	B	C	D	E	F	Weight (kg)
								(mm)	(mm)	(mm)	(mm)	(mm)	(in.)	
PH63C	5	—	152	—	—	200	80	11	6,4	22	83	22	—	4,9
PH83C	7	—	190	—	—	249	80	11	9,5	25,4	83	22	—	6,6
PH113C	14	—	229	—	—	280	80	14,3	9,5	29	83	29	—	8,0
PH303C	27	266,7	375	—	—	540	110	27	36,5	38	170	54	5/8-18 UNF	32,3
PH82K	7	266,7	207	125	300	245	80	52	25,4	16	83	22	5/8-18 UNF	9,5
HST11S*	10	—	150	—	—	409,6	80	—	—	—	65	29	—	14,5

\* Max bar size 2.3622"

**LOCK-JAW™ PULLER ACCESSORY KITS FOR THE HYDRA LOCK-JAW™ PULLER NO. PH83C**



Order No.	Description
K82	Accessory kit for the Hydra Lock-Jaw™ puller PH83C. Includes 2-way puller head, 2-jaws, 2 threaded legs and sturdy carrying/storage case. Wt. 6,2 kg.

**LOCK-JAW™ PULLER ACCESSORY KITS FOR THE PH83C LOCK-JAW™ HYDRAULIC PULLER**



Order No.	Description
K83	Accessory kit for PH83C Hydra Lock-Jaw™ hydraulic puller. Includes 2/3-way puller head, 3-jaws, 3 threaded legs (5/8-18 thread) and sturdy carrying/storage case. Also can be used with 1123, 1124, 1130 pulling attachments. 10,4 kg.

**PULLER ACCESSORY CONVERTS PH113C INTO A HYDRAULIC STRAIGHTENING TOOL**

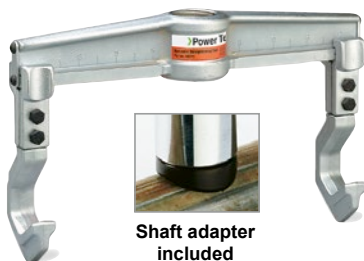

Good for straightening mechanical shafts, round bars, etc. Simply remove pump and cylinder from puller head and insert them into the straightening tool accessory. This product is widely used in steel mills, wire roll companies, wire extruding companies, textile industry, and any straightening situation where portability and power are required. Contoured heat-treated shaft adapter included.

Order No.	Description
HST11	Spread: 89 to 410 mm, Reach: 150 mm. 9,5 kg.

**LONG JAW SET FOR PH83C AND PH113C LOCK-JAW™ PULLERS**



This long jaw set is the perfect addition to the PH83C or PH113C Lock-Jaw™ hydraulic pullers. The extra long jaws give you the added capability of pulling a wider variety of parts. Jaw capacity is 8 tons when used with the PH83C puller; 15 tons when used with the PH113C puller.

Order No.	Description
1188	Spread: 280 to 317 mm, Reach: 317 mm. Wt. 5,2 kg.

Pullers

Model Shown:

**PH53CR, PH172, PH303**



**CAUTION:** Always use a 3-jaw puller where clearance permits in order to provide a more stable setup and a more even pulling force.

**Ordering Information - Puller Only**

Order No.	Cap. (ton)	Jaws Qty.	Jaw Reach (mm)	Jaw Spread (mm)	Jaw Thickness (mm)	Jaw Width (mm)	Weight (kg)
1066	16	3	292	508	20,6	32,5	16,3
1074	27	3	494	864	28,6	41,3	40,9
1080	45	3	702	1118	35,7	47,6	86,7

**Features**

**REMOVE GEARS, BEARINGS, AND OTHER PRESS-FITTED PARTS WITH SPEED AND EASE.**

- Broad capacity range of 9, 27, and 45 tons.
- 4,5 and 9 ton sets include: single-acting, spring return hydraulic cylinder, hose, coupler dust cap, single-speed hydraulic hand pump, and puller.
- 27 and 45 tons sets include: Power-Twin® single-acting, spring return hydraulic cylinder, hose, coupler dust cap, single-speed hydraulic hand pump puller, adjusting screw and crank.
- Hydraulic cylinder of all models is readily removable from puller for use with pump in other hydraulic applications. You get maximum maintenance versatility for your investment.
- Fed. Spec.: GGG-P-00781-D

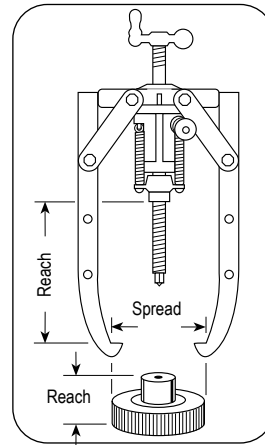

**9 TON CAPACITY, 2/3-JAW PULLER**

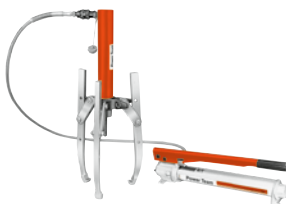
	Order No.	Description
	PH103C	Combination 2-jaw/3-jaw puller, 10 ton capacity. Set includes 1060 9 ton puller, RPS1010 cylinder and pump set, and 202179 threaded adapter. Wt., 23,6 kg.
	PH103CR	Combination 2-jaw/3-jaw puller, 9 ton capacity. Set includes 1060 10 ton puller, 202179 threaded adapter, and C1010C cylinder only. (Pump and hose not included). Wt., 14,5 kg.
<p><b>NOTE:</b> This puller may be used with any 10 ton single-acting cylinder having a 2 1/4"-14 straight collar thread.</p>		

**16 TON CAPACITY, 2-JAW PULLER**

	Order No.	Description
	PH172	2-jaw puller (1064) with RT172 center-hole Power-Twin® cylinder, cylinder half coupler, P55 pump 1,8 meter hose, hose half coupler, 1"- 8 x 508 mm long adjusting screw, and adjusting crank.
	1064	Puller only. (Cylinder, pump, hose, coupler, screw, and crank not included). Wt., 10,0 kg.

**27 TON CAPACITY, 3-JAW PULLER**

	Order No.	Description
	PH303	3-jaw puller with RT302 center-hole Power-Twin® cylinder, cylinder half coupler, P55 pump, 1,8 m. hose, hose half coupler, 1 1/4"- 7 x 610 mm large adjusting screw, and adjusting crank. Wt., 67,7 kg.
	PH303R	3-jaw puller with screw and crank, and RT302 center-hole twin cylinder. Wt., 59,0 kg.
	1074	Puller only. (Cylinder, pump, hose, coupler, screw, and crank not included). Wt., 40,0 kg.

**45 TON CAPACITY, 3-JAW PULLER**

	Order No.	Description
	PH503	3-jaw puller with RT503 center-hole Power-Twin® cylinder, cylinder half coupler, P55 pump, 1,8 m. hose, hose half coupler, 1 5/8"- 5 1/2 x 722 mm long adjusting screw, and adjusting crank. Wt., 130,0 kg.
	1080	3-jaw puller only. (Cylinder, pump, hose, coupler, screw, and crank not included). Wt., 86,7 kg.

Pullers

Model Shown:  
**PPH50**

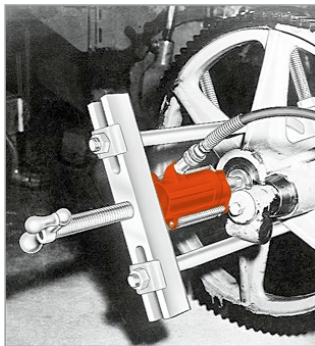
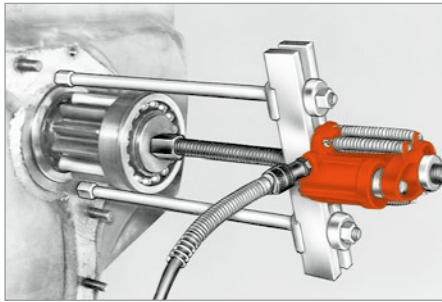

**Features**

**THE POWER TO MAKE IMPOSSIBLE JOBS BECOME ROUTINE.**

- Can apply a hydraulic pushing or pulling force, depending on how the puller is set up.
- Each unit includes perfectly matched hydraulic components that can be detached from the Bi-Directional™ Puller for other tasks requiring dependable power, and assuring maximum return on your investment.
- Optional leg kits adapt your Bi-Directional™ Puller to extra long or extra short reach.
- Not CE compliant
- A wide variety of threaded adapters, bearing pulling attachments and internal pulling attachments can be used in combination with our Bi-Directional™ Pullers.



**Assembling the tool to apply pushing or pulling force:**

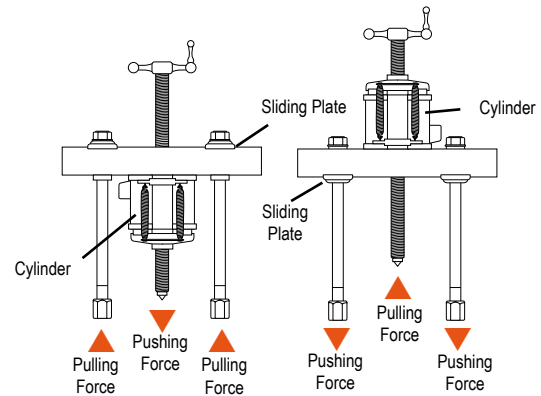

1. Determine if you want the tool's forcing screw to push or pull.
2. To exert pushing force, the forcing nut is installed beneath the cross block, as shown on left.
3. To cause the forcing screw to pull, the forcing nut is placed on top of the cross block.
4. The sliding plates must always be placed on the opposite side of the cross block from the forcing nut.

**SELECTION AND CAPACITY RATING** – Each Bi-Directional™ Puller's specified tonnage "capacity" is determined using its standard legs in tension. Using longer legs, or a setup in which the legs are in compression, will reduce the "capacity." Always select the largest "capacity" puller and the shortest legs that will fit the job.

**POWER-TWIN® CYLINDER** – This unique center-hole cylinder powers each Bi-Directional™ Puller screw runs right between the twin spring cylinder. A basic head allows you to change from a tapped hole to a plain hole by merely changing the head insert.

**17.5 TON CAPACITY BI-DIRECTIONAL™ PULLER**

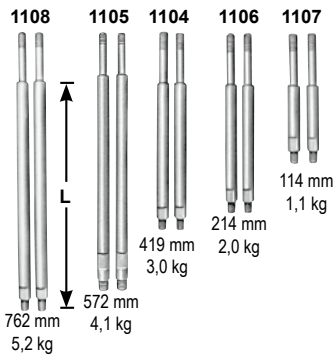
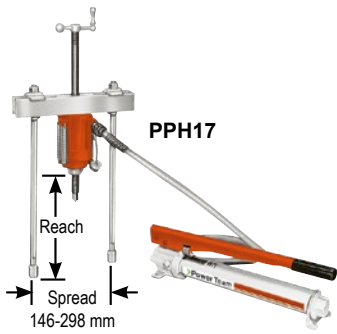

**Leg Ends** – Upper leg ends are threaded 3/4"-16.  
Lower leg ends are threaded 5/8"-25 mm long

**NOTE:** L = leg length: 114, 241, 419, 572 and 762 mm; subtract 124 mm from leg length to determine reach when using leg end caps.

Order No.	Description
<b>PPH17</b>	Bi-Directional™ Puller with RT172 center-hole Power-Twin® cylinder, cylinder half coupler, P55 pump, 9767 1,8 m. hose, 9798 hose half coupler, 419 mm legs, 24827 leg ends, 1"-8 x 508 mm large adjusting screw and adjusting crank. Wt., 26,8 kg.
<b>PPH17R</b>	Bi-Directional™ Puller with RT172 center-hole Power-Twin® cylinder, cylinder half coupler, but without P55 pump, 9767 1,8 m. hose and 9798 hose half coupler. Wt., 18,1 kg.
<b>1062</b>	Puller only. (Cylinder, pump, hose, coupler, screw and crank not included). Wt., 9,1 kg.
<b>USE WITH:</b>	
Bearing pulling attachment:	<b>1124 and 1130</b>
Pully Pulling attachment:	<b>679</b>
Internal Pulling attachment:	<b>1154</b>
Legs:	<b>1104, 1105, 1106, 1107 and 1108</b> - Pair of legs for 17.5-ton "capacity" Bi-Directional™ Puller.

**30 TON CAPACITY BI-DIRECTIONAL™ PULLER**

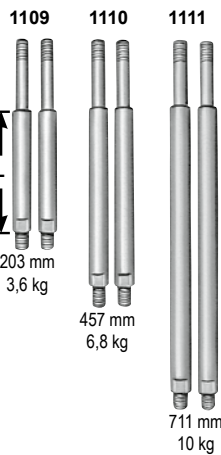
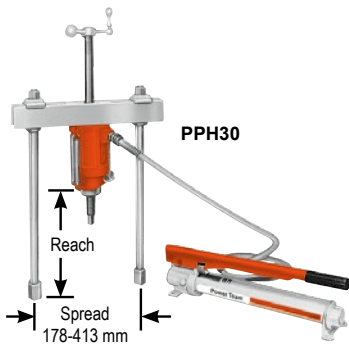

**Leg Ends** – are threaded 1"-14 x 32 mm.

**NOTE:** L = leg length: 203, 457 and 711 mm; subtract 149 mm from leg length to determine reach when using leg end caps.

Order No.	Description
<b>PPH30</b>	Bi-Directional™ Puller with RT302 center-hole Power-Twin® cylinder, cylinder half coupler, P55 pump, 9767 1,8 m. hose, 9798 hose half coupler, 457 mm legs, 28390 leg ends, 1 1/4"-7 x 610 mm lg. adjusting screw and adjusting crank. Wt., 46,3 kg.
<b>PPH30R</b>	Bi-Directional™ Puller with RT302 center-hole Power-Twin® cylinder, cylinder half coupler, but without P55 pump, 9767 1,8 m. hose and 9798 hose half coupler. Wt., 37,2 kg.
<b>1070</b>	Puller only. (Cylinder, pump, hose, coupler, screw and crank not included). Wt., 19,1 kg.
<b>USE WITH:</b>	
Bearing pulling attachment:	<b>680</b> (Use two 8012 adapters to connect to puller.)
Pully Pulling attachment:	<b>679</b>
Internal Pulling attachment:	<b>1166</b>
Legs:	<b>1109, 1110 and 1111</b> - Pair of legs for 30 ton "capacity" Bi-Directional™ Puller.

**50 TON CAPACITY BI-DIRECTIONAL™ PULLER**

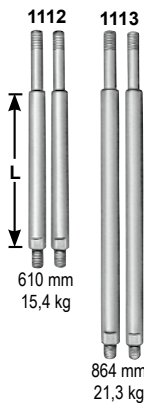
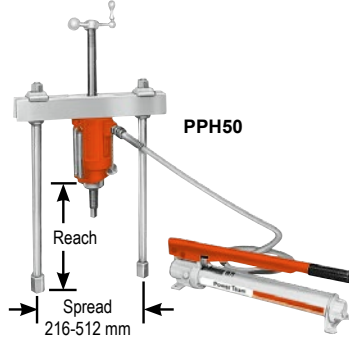

**Leg Ends** – are threaded 1 1/4"-12 x 44,5 mm.

Order No.	Description
<b>PPH50</b>	Bi-Directional™ Puller with RT503 center-hole Power-Twin® cylinder, cylinder half coupler, P55 pump, 9767 1,8 m. hose, 9798 hose half coupler, 610 mm legs, 1 5/8-5 1/2 x 722 mm lg. adjusting screw and adjusting crank. Wt., 91,3 kg.
<b>PPH50R</b>	Bi-Directional™ Puller with RT503 center-hole Power-Twin® cylinder, cylinder half coupler, but without P55 pump, 9767 1,8 m. hose and 9798 hose half coupler. Wt., 82,2 kg.
<b>1076</b>	Puller only. (Cylinder, pump, hose, coupler, screw and crank not included.) Wt., 48,1 kg.
<b>USE WITH:</b>	
Bearing pulling attachment:	<b>1128</b>
Legs:	<b>1112 and 1113</b> - Pair of legs for 45 ton "capacity" Bi-Directional™ Puller.

Pullers

Model Shown:

**PHP8H, PHP8R**



**Features**

**IDEAL FOR INSTALLING A WIDE VARIETY OF PRESS-FIT PARTS.**

- Power Team pushers have been rigorously tested for top performance and reliability at maximum capacity.
- These pushing systems are covered by Power Team's exclusive PowerThon™ Limited Lifetime Warranty — assuring you of the highest quality and reliability.

**BEARING PUSHER KITS**

- Portable pushing kits include an external Lock-Jaw™ puller, an internal puller, hydraulic cylinder, and a tri-section pulling attachment, all in one compact, lightweight unit complete with carrying case.

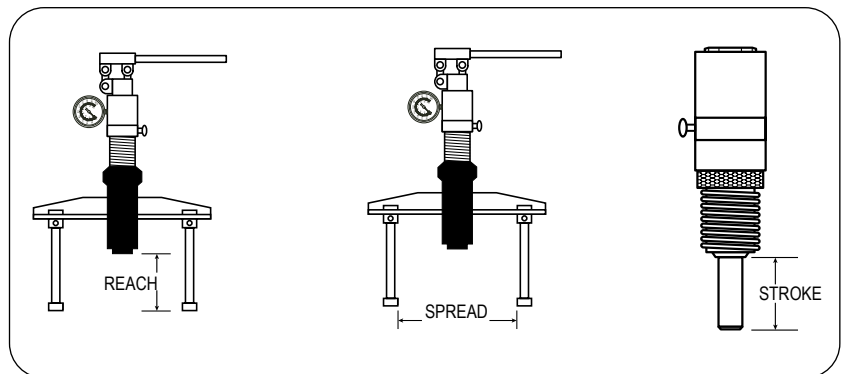
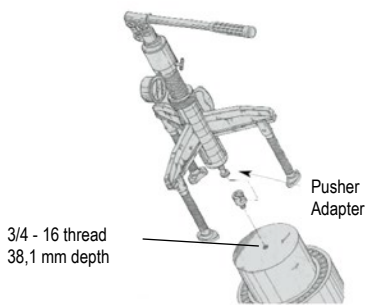

**Ordering Information**

Order No.	Description	Cylinder Cap. (ton)	Reach (mm)	Spread (mm)	Stroke (mm)	Weight with Case (kg)
PHP8H	Manual-Hydraulic Pusher	7	55 - 385	58 - 270	82	33,5
PHP8H-1	Manual-Hydraulic	7	55 - 385	58 - 270	82	53,0



**IMPORTANT SAFETY INFORMATION:** Power Team recommends the use of protective blankets for all pushing operations. For ease of visual clarity, we have shown the pusher application photos without these safeguards.

**MECHANICAL AND HYDRAULIC PULLER RETENTION BLANKET**



- Made of see-through, high-tensile, tear resistant material.
- The clear retention blankets allow you to visually monitor the job from start to finish.
- Ideal for use with pullers and forcing presses.
- Unlike rigid, fixed guards, these blankets can be wrapped and strapped around a job.
- Offers additional protection for the user during dismantling jobs,
- Suitable for use in combination with many pullers.

Order No.	Size		Number of Straps	Weight	
	in.	mm.		lbs.	kg.
PB1230D	12 x 30	304 x 762	2	2.80	1.27
PB2036D	20 x 36	508 x 914	2	4.20	1.91
PB2860D	28 x 60	711 x 1524	3	9.30	4.22
PB3372D	33 x 72	838 x 1828	3	11.70	5.31
PB44120D	44 x 120	1117 x 3048	4	24.20	10.98
PB51156D	51 x 156	1295 x 3964	4	34.40	15.60

**NOTE:** Custom sizes are available on a special order basis. Please consult factory.

**JOB-SITE AND MAINTENANCE SECURITY CHESTS**

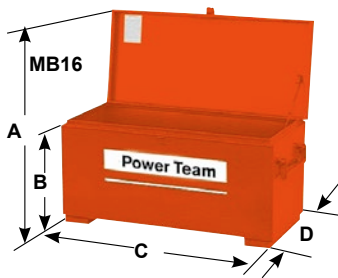

Protect your valuable tools and equipment from theft and weather. When the day's work is finished, you want to rest assured that your tools and equipment will be present the next day. These rugged, lockable chests are the answer that many of our customers have been asking for.

- Rugged, 1,6 mm steel construction with fully arc welded seams for extra strength and weather protection.
- Full length piano hinges, mating cover to body, protect against weather and theft.
- Single or double latch security tabs for padlocks.
- Mechanical cover supports, two 57 mm high skirts.
- Fold-down 19 mm pipe handles on each end of chest.
- Pre-drilled for optional casters, which enhance mobility.
- Durable baked enamel finish.

Order No.	A	B	C	D	Cap. (m <sup>3</sup> )	Storage Wt. (kg)	Optional Accessories Caster Wheels
	(mm)	(mm)	(mm)	(mm)			
MB5	883	356	813	483	0,14	30,9	 251646– Set of four 4" casters (two swivel and two rigid). Furnished with mounting screws. Wt., 5,7 kg. 251647 – Set of four 6" casters (two swivel and two rigid). Furnished with mounting screws. Wt., 7,0 kg.
MB8	1010	483	1670	483	0,25	40,9	
MB16	1264	610	1219	610	0,45	57,2	

Pullers

Model Shown:  
**PH553C**

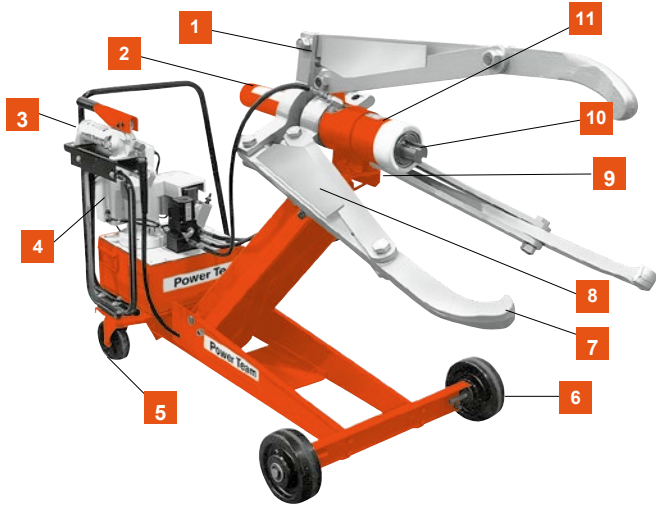

**Features**

**ENFORCER 55**

- 1 Puller can be assembled in 2 or 3-jaw configurations.
- 2 Hydraulically-actuated jaws allows cylinder to move in or out with a safe, secure grip on workpiece.
- 3 Hydraulic lift system for easy, precise position of puller.
- 4 Unique dual pump arrangement. Low pressure pump positions, holds and opens jaws. The high pressure pump advances and retracts the pushing cylinder without releasing clamped jaws.
- 5 Swivel casters give ease of mobility.
- 6 Large wheels make movement of cart easy.
- 7 Super Lock-Jaw™ feature means the harder the pull, the tighter the puller jaws grip. No chains or cages required to keep puller jaws from slipping or springing off the part being pulled.
- 8 Guards at pinch points protect operator.
- 9 Puller can be mounted on cart 90 degrees to right or left of puller cart centerline, permitting use in tight quarters, such as between machinery.
- 10 Self-centering design puller jaws will automatically grip work evenly.
- 11 Choice of cylinder with a 169 mm or 337 mm stroke.



**Pushing Adapters**

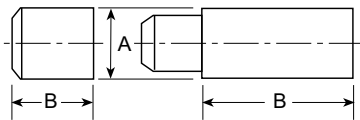

Order No.	Qty. *	A (mm)	B (mm)
251002	1	69,9	69,9
350593**	2	69,9	152,4
350594	1	69,9	76,2
350637	1	69,9	254,0

\* Number of adapters supplied with each Enforcer.  
\*\* Only 1 for units with 13.25" stroke.



**Conversion Kit**

**Conversion Kit No. 251468.** Kit converts PH553C series to PH553CL series. Jaws are 305 mm longer. Kit contains three jaws and six straps with guards. Wt., 114 kg.



**IMPORTANT SAFETY INFORMATION:** Power Team recommends the use of protective blankets for all pushing operations. For ease of visual clarity, we have shown the pusher application photos without these safeguards.

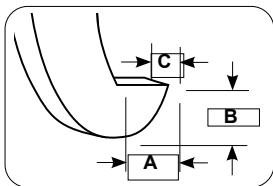

**Note:** Four cylinder extensions (not pictured) are included. The included lifting eyes (not pictured) permit use of an overhead crane to raise entire assembly.

**Ordering Information**

Order No.	Puller Jaw Tip			Min. Spread (mm)	Reach Min. Spread (mm)	Max. Spread (mm)	Reach Max. Spread (mm)	Overall Length * (mm)	Cyl. Stroke (mm)	Power Source Requirements (mm)	Prod. Wt. (kg)
	A (mm)	B (mm)	C (mm)								
PH553C-E220	22,4	31,8	47,8	101,6	559	1,219	356	2,286	159	230 V, 50 Hz, 15 Amp Capacity	339
PH553C13-E220	22,4	31,8	47,8	101,6	381	1,219	178	2,286	337	230 V, 50 Hz, 15 Amp Capacity	352
PH553CL-E220	22,4	31,8	47,8	63,5	829	1,149	737	2,591	159	230 V, 50 Hz, 15 Amp Capacity	366
PH553C13-E220	22,4	31,8	47,8	63,5	651	1,149	559	2,591	337	230 V, 50 Hz, 15 Amp Capacity	379

\* Cart and Puller (cart width = 813 mm)

Model Shown:  
**PH1002**

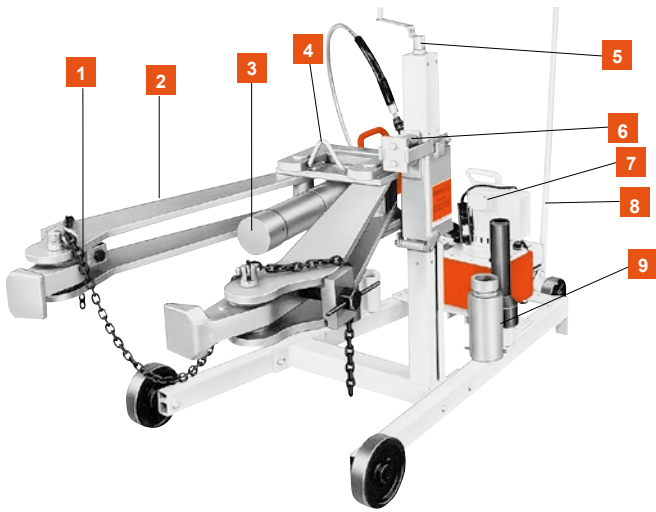

An ideal puller for steel mills, mines, oil fields, utility projects, paper mills, construction sites, railroads, airline shops, shipyards or anywhere else where large equipment and machinery pose tough maintenance challenges.

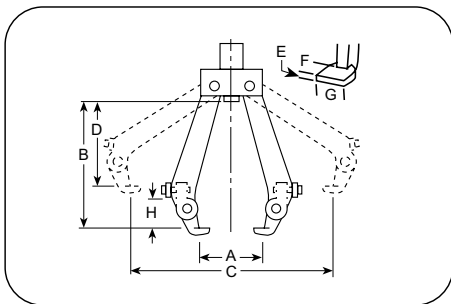

**Features**

**ENFORCER 100**

- 1 Adjustable jaws mean they always pull on a flat surface. Retaining chain holds jaws in place during positioning.
- 2 Lock-Jaw™ feature means jaws grip progressively tighter as more pulling force is applied.
- 3 91 ton hydraulic cylinder is single-acting, spring return type with a maximum working pressure of 700 bar.
- 4 Lifting bracket allows puller to be lifted if the workpiece center is more than 914 mm off the floor.
- 5 Adjusting screw allows operator to move vertical position of the puller.
- 6 Spring loaded feature means Enforcer 100 will align itself on uneven pulls.
- 7 Hydraulic pump is a 2-stage, high pressure unit controlled by remote hand switch with 7,6 m cord.
- 8 Tow bar provides puller with plenty of mobility.
- 9 Pushing adapters have a diameter of 105 and 63,5 mm.



**Ram Extensions**

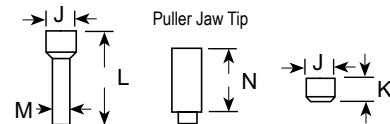

Order No.	Adapter Type	Amount included w/puller	J (mm)	K (mm)	L (mm)	M (mm)	N (mm)
44745	Push	1	105	—	343	63,5	—
44766	Ext.	4	105	—	—	—	203
303045	Push	1	105	79,4	—	—	—

**“ENFORCER 100” UNIVERSAL PULLER**

Order No.	Description
PH1002-E220	91 ton, 2-jaw universal hydraulic puller. Includes: 2-jaw Grip-O-Matic® puller, PE552S-E220 2-speed electric/hydraulic power unit, C10010C 91 ton hydraulic cylinder with 260 mm stroke and six adapters. Wt., 404 kg.
PH1002J	Same as PH1002-E220, but without hydraulic power unit. Wt., 404 kg.
PE552S-E220	Pump only. 0,84 kW, 220 volt, 50 Hz, single phase, draws 13 amps at full load.

Note: Also available in E110

**Ordering Information**

Order No.	Min. Spread	Reach Min. Spread	Max. Spread	Reach Max. Spread	Puller Jaw Tip			Max. Thick. Workpiece	Vertical Stroke Adjust.	Overall Length	Max. Thickness Workpiece	Wheel Dia.	Power Source Requirements
	A (mm)	B (mm)	C (mm)	D (mm)	E (mm)	F (mm)	G (mm)						
PH1002-E220	381	1067	1219	864	25,4	57,1	127	260	305 - 914	2388	305	260	220 V, 50 Hz, 13 Amp Capacity
PH1002J													

Model Shown:

**PR3100J, PR3100S**



**Features**

**UNIVERSAL RAILROAD AXLE JOURNAL ROLLER BEARING PULLER/INSTALLER.**

- Quickly remove or install tapered roller bearings.
- With both sling and jack models available and two pumps to choose from, you can tailor the unit to match your needs.
- The industry standard in most wheel shops.
- Each unit will service a full line of bearings with rotating end caps, from class B thru GG.
- Designed with the cooperation of major bearing manufacturers.
- Fast, simple, one-person operation with 91-tons of pulling force provided.
- Completely portable for easy, convenient positioning and out-of-the-way storage.
- Each unit complete with a heavy-duty 91-ton hydraulic cylinder, 700 bar pump with remote control solenoid valve, hydraulic pressure gauge (11543), a pulling shoe and installing tube.
- CSA certified (LR19814)



Our roller bearing pullers are ideal for replacing tough, worn-out bearings on RR freight cars.

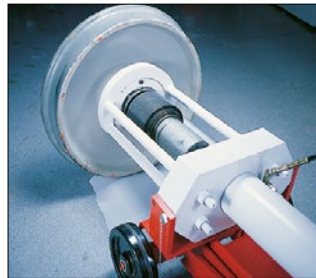

The photo above shows the Universal Puller in position on the roller bearing assembly, which is ready for removal.



**Protective Blankets**



Power Team has protective blankets available which may afford protection from injury to users and others should part breakage occur. For more information, see page 242.



**CAUTION**

Power Team recommends the use of these blankets for all pushing, pulling, pressing, and lifting applications.

**Ordering Information**

Order No.	Model Type	Cylinder Type	Valve Type	Kw	Pump Information Phase	Voltage
PR2100J-E220 †	Jack	Double-Acting	Solenoid	1,5 **	1	230 V*
PR3100J-E380 †	Jack	Double-Acting	Solenoid	2,2	3	400 V*
PR2100S-E220 †	Sling	Double-Acting	Solenoid	1,5	1	230 V*
PR3100S-E380 †	Sling	Double-Acting	Solenoid	2,2	3	400 V*

\* Prewired at factory for these voltages. Other voltages available upon request.

\*\* The 2 hp, 115VAC requires 30 amp service.

† Equipped with hydraulic pressure gauge 11543.

**▶ Tooling Ordering Information**

**IMPORTANT:** This tooling chart applies only to standard AAR configurations for freight car applications. In order to provide adapters needed to service housing-type locomotive and passenger car bearings, as well as metric bearings, Power Team must be provided with the following information. Bearing manufacturer's name and general arrangement drawing number, size of bearing to be serviced, railroad name and location and part numbers of adapters already in your possession if you currently own a Puller/Installer.

Tool Description	Class and size of bearing assembly - TBU & SP "Metric Tooling"			
	120	130	140	150
Pulling Shoe, Insert Adapter	351830	30512	30521	30520
Guide Tube & Cap Screw Assy.	253341	253342	253343	253344
Cap Screw *	253339	253394	253339	253395
Guide Tube Adapter	212247	21247	21247	21247
Installing Tube Adapter Ring	253335	253336	253337	253338

\* Screws are supplied with the guide tube and should be ordered as replacements only.

Tool Description	Class and size of bearing assembly to be serviced									
	Class B 108 x 203	Class C 127 x 229	Class D 140 x 254	Class E 152 x 279	Class EE 140 Axle	Class EE 152 Axle	Class F 165 x 305	Class G 178 x 305	Class G 165 Axle	Class GG 165 Axle
Pulling Shoe	420845 is included as part of basic machine - Do Not Order							420846	420846	420846
Pulling Shoe, Insert Adapter	30522	30512	30521	30520	30520	30519	30519	—	—	—
Guide Tube & Cap Screw Assy.	253313	253314	253317	253318	253316	253327	253320	253321	253319	253323
Cap Screw *	253156	253349	253308	253155	253307	253308	253310	253326	253309	253309
Guide Tube, No Adapter	23934	21248	21248	21247	21247	21247	21247	21247	21247	21247
Installing Tube	30416 is included as part of basic machine - Do Not Order							30417	30417	30417
Installing Tube Adapter Ring	21242	21258	21256-1	21255-1	21255-1	21257-1	21257-1	30586	30585	30585

\* Screws are supplied with the guide tube and should be ordered as replacements only.

**NOTE:** Adapters listed above are for servicing the following roller bearing assemblies: Brenco "Crown-Taper", New Departure-Hyatt "Hy-Roll Taper", SKF "Expediter" and Timken "AP".

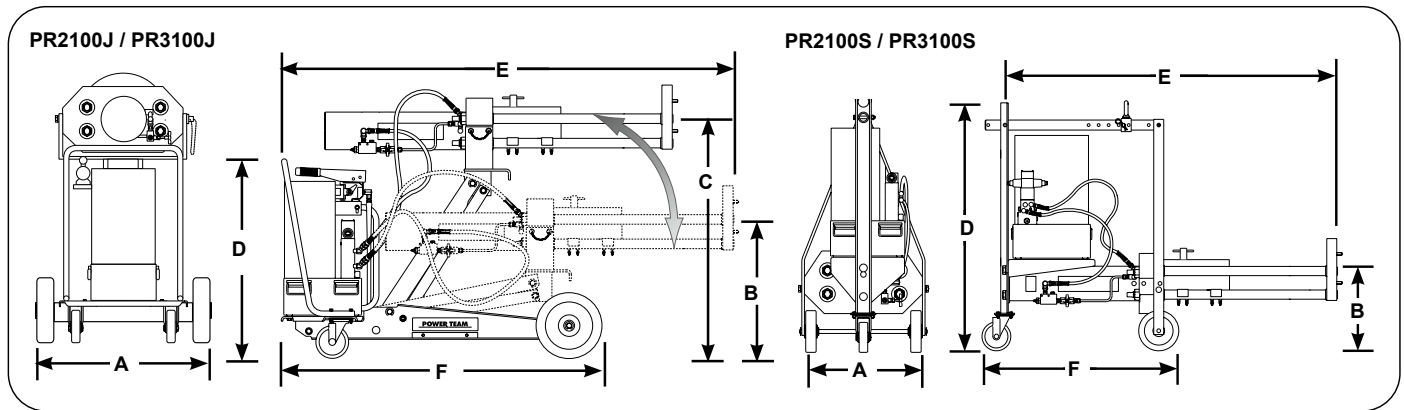

**▶ Technical Dimensions**

Order No.	A	B	C	D	E	F	Stroke (mm)	Capacity		Advance (mm/min.)	Speed		Weight (kg)
	(mm)	(mm)	(mm)	(mm)	(mm)	(mm)		Pull (tons)	Inst. (tons)		Pull (mm/min.)	Inst. (mm/min.)	
PR2100J	813	383	1059	912	1981	1493	394	91	62	900	81	113	528
PR3100J	813	383	1059	912	1981	1493	394	91	62	900	81	113	520
PR2100S	619	279	—	1283	1632	985	394	91	62	900	81	113	455
PR3100S	619	279	—	1283	1632	985	394	91	62	900	81	113	458

Pullers

Model Shown:  
**1166**



**Features**

**RECOMMENDED FOR THE REMOVAL OF BEARINGS, BEARING CUPS, BUSHINGS AND OIL SEALS.**

- Handles internal pulling jobs, such as, bearing/bearing cup removal, bushing removal, oil seals, etc.
- Remove hard to get at parts easily and without damage!
- Use with corresponding Power Team Slide Hammer or Bi-Directional™ Puller
- Adjustable jaws fit various diameters
- Meets Fed. Spec.: GGG-P-00781-D

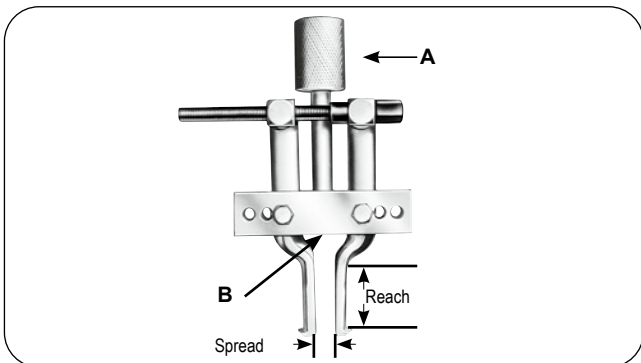

**CAUTION**

These attachments may not withstand the full tonnage of the pullers they are used with. The shape and condition of the part being pulled affects the tonnage at which the jaws may slip off. Always select the largest attachment which will fit behind the part being pulled.

**Ordering Information**

Order No.	Jaw		A (in.)	B (in.)	Weight (kg)	Application
	Spread (mm)	Reach (mm)				
1153	38,1 - 127	54	1 - 14	5/8 - 18	1,9	Use with 927 and 938 Bi-Directional™ Puller,
1150	38,1 - 152	102	1 - 14	5/8 - 18	2	
1151	38,1 - 178	133	1 - 14	5/8 - 18	2	
1152	38,1 - 152	102	—	5/8 - 18	1,6	Use with 927 and 938 Bi-Directional™, 1155 and 1156 slide hammer pullers, or 24832 and 24833 puller screw.
1154	38,1 - 152	102	1 - 8	5/8 - 18	2	Use with PPH17.
1165	76,7 - 229	149	1 1/2 - 12	1 - 14	6,1	Use with 939 Bi-Directional™ Puller.
1166	76,2 - 229	149	1 1/4 - 7	1 - 14	6,1	Use with PPH30.

Order No.	Length (in.)	Puller Screws Threads (in. - thd.)	Weight (kg)	Application
24832	349 mm long	5/8 - 18	0,5	Use with 1150, 1151, 1152, and 1153. Acts as a regular forcing screw when threaded directly into block of pulling attachment.
24833	140 mm long	5/8 - 18	0,2	Use with 1150, 1152, and 1153. Acts as a regular forcing screw when threaded directly into block of pulling attachment.

Model Shown:  
**1122**



**Features**

**USED WHERE SPACE DOES NOT PERMIT, HOOKING PULLER JAWS DIRECTLY ON PART TO BE PULLED.**

- “Knife-like” edges fit behind bearings and other hard-to-grip parts for easy removal, even where clearance is limited.
- Usable with both Lock-Jaw™ pullers and Bi-Directional™.
- All puller blocks are made from forged alloy steel
- Meets Fed. Spec.: GGG-P-00781-D

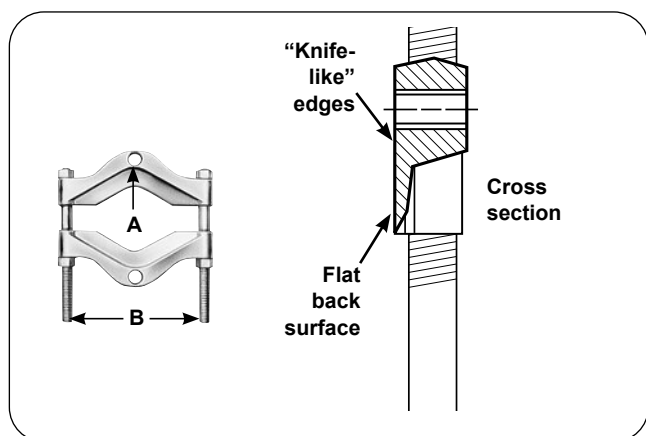

PULLING ATTACHMENT ACCESSORY		
Order No.	Description	
1128	“Knife-like” edges of attachment fit behind bearings or other parts for easy removal with “Enforcer 55”, even if space does not permit hooking puller jaws directly to part being pulled.  Spread: 127 tot 327 mm. Wt., 45,5 kg.	

**Ordering Information**

Order No.	Spread		A	B	Weight	Application
	Max. (mm)	Min. (mm)				
1121	22,2	6,4	5/16 - 18	43	0,3	1020, 1022, and 1023.
1122	51,0	3,2	3/8 - 16	62	0,6	1024, 1025, 1026, 1027, 7392 and 7393.
1123	117,0	9,5	5/8 - 18	111	2,3	1035, 1036, 1037, 1038, and 927.
1124	5,75	12,7	5/8 - 18	152	5,4	1035, 1040, 1041, 1042, PH172, PPH17, and 938.
1126	203,0	16,0	1 - 14	181	9,0	1043, and 939.
1127	340,0	19,0	1 - 14	260	18,8	939, PH302, and PPH30.
1128	327,0	127,0	1 3/4 - 12	330	45,4	PH302*, PH502*, PH553C, and PPH50. (When using 1128 with PPH50, two 8024 adapter are required to connect PPH50 to the puller tees).
1130	219,0	12,7	5/8 - 18	152	5,4	1035, 1040, 1041, 1042, PH172, PPH17, and 938.

**V-BELT PULLEY PULLING ATTACHMENTS**

Order No.	Spread		A	B	Weight	Application
	Max. (mm)	Min. (mm)				
679	149,0	45,0	5/8 - 18	152	2,0	1035, 1036, 1037, 1038, and 927.
680	254,0	42,3	5/8 - 18	257	10,0	1039, 1040, 1041, 1042, PH172, PPH30* and 938. (When using 680 with PPH30, two 8012 adapters are required).

\* Indicates discontinued puller model.

Pullers

**GEAR AND PULLEY PULLERS**

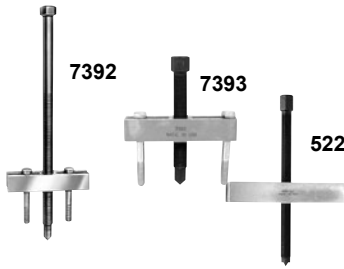

Ideal for pulling many small parts having tapped holes. The 7392 and 7393 may be used with the 1122 pulling attachment to remove bearings, etc. Pullers include two hex head cap screws, 3/8" – 16 NC x 76 mm long. Spread: 38 - 108 mm. Width of puller block is 124 mm. Cap screws are not included with the 522, but any cap screws up to 12,7 mm diameter may be used. The 522 spread, when used with 12,7 mm dia. cap screws, is 51 - 197 mm. Width of the 522 puller block is 209 mm.

Order No.	Description
7392	Puller with 5/8"-18 x 330 mm long screw. Wt., 0,9 kg.
7393	Puller with 5/8"-18 x 140 mm long screw. Wt., 0,7 kg.
522	Puller with 3/4"-16 x 295 mm long screw. Wt., 2 kg.

**FLANGE TYPE PULLER**



Slotted holes in puller body permit cap screws to be positioned to handle bolt-circle diameters from 38 - 117 mm.

Order No.	Description
518	Flange type puller, includes 3 cap screws, 3/8" – 24 NF x 76 mm long and 3 cap screws 3/8" – 16 NC x 76 mm long. Forcing screw is 5/8" - 18 x 127 mm long. Wt., 4,9 kg.

**FEMALE THREADED ADAPTERS**

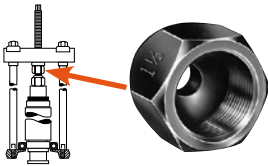

Use these adapters on the ends of Bi-Directional™ Puller forcing screws, legs, or slide hammers in the removal and installation of shafts, axles, and housings.

Order No.	Description	
8044	Set No. 8044 – consists of a set of 6 adapters (8037-8042).	
Order No.	Female End "A" (in.)	Female End "B" (in.)
8035*	1/2" - 20	5/8" - 18
8036*	1" - 14	1" x 14
8037	5/8" - 18	5/8" - 18
8038	5/8" - 18	3/4" - 16
8039	5/8" - 18	7/8" - 14

  

Order No.	Female End "A" (in.)	Female End "B" (in.)
8040	5/8" - 18	1" x 14
8041	5/8" - 18	1 1/8" - 12
8042	5/8" - 18	1 1/4" - 12
8043*	5/8" - 18	1 1/2" - 12

**Note:** All adapters available separately.

\* Not included in set No. 8044. Order separately.

**MALE-FEMALE THREADED ADAPTERS**

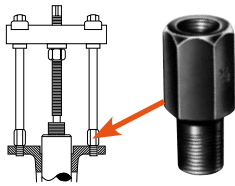

These adapters are used on ends of Bi-Directional™ Puller legs, with forcing screws or slide hammers to assist in pulling shafts, bearing caps, pinions, and many other parts.

Order No.	Female End (in.)	Male End (in.)	Length (mm)	Order No.	Female End (in.)	Male End (in.)	Length (mm)
8000	5/8" - 18	1/4" - 20	57,2	8015	5/8" - 18	3/4" - 10	57,2
8001	5/8" - 18	5/16" - 18	57,2	8016	1" - 14	3/4" - 10	63,5
8002	5/8" - 18	7/16" - 14	57,2	8017	5/8" - 18	7/8" - 14	57,2
8003	5/8" - 18	7/16" - 20	57,2	8018	5/8" - 18	7/8" - 9	57,2
8004	5/8" - 18	3/8" - 24	57,2	8019	5/8" - 18	1" - 14	57,2
8005	5/8" - 18	3/8" - 16	57,2	8020	1" - 8	5/8" - 18	76,2
8006	5/8" - 18	1/2" - 20	57,2	8021	1" - 8	1" - 4	76,2
8007	5/8" - 18	1/2" - 13	57,2	8022	5/8" - 18	1/8" pipe	57,2
8008	5/8" - 18	9/16" - 18	57,2	8023	1 1/4" - 12	1" - 14	114,3
8009	5/8" - 18	9/16" - 12	57,2	8024	1 1/4" - 12	1 3/4" - 12	114,3
8010	5/8" - 18	5/8" - 11	57,2	8025	1 1/4" - 7	5/8" - 18	101,6
8011	1" - 14	5/8" - 11	63,5	8027	1 1/4" - 7	1" - 14	101,6
8012	1" - 14	5/8" - 18	81,0	8028	1 5/8" - 5 1/2	1" - 8	101,6
8013	5/8" - 18	3/4" - 16	57,2	8029	1 5/8" - 5 1/2	1" - 14	101,6
8014	1" - 14	3/4" - 16	63,5				

NOTE: Nos. 8000 - 8029 - each sold individually.

**STEP PLATE ADAPTER SETS**

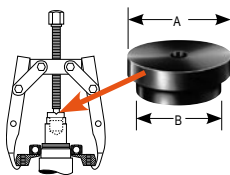

Power Team step plate adapters are necessary for pulling and installing bearings, gears, or other parts on hollow shafts or housings. Puller screw forces against step plate adapter, as shown at right. May be used with Power Team jaw-type pullers, Bi-Directional™ Pullers and shop presses.

Order No.	Description
8075	Set of 11 adapters (8057-8067).

  

CONTENTS OF 8075 SET			CONTENTS OF 8076 SET		
Order No.	Dia. "A" (mm)	Dia. "B" (mm)	Order No.	Dia. "A" (mm)	Dia. "B" (mm)
8057	25,4	19,1	8063	47,5	38,1
8058	28,4	22,1	8064	50,8	41,1
8059	31,8	25,4	8065	53,8	44,5
8060	34,8	28,4	8066	60,2	47,5
8061	41,1	31,8	8067	63,5	50,8
8062	44,5	34,8			

Order No.	Dia. "A" (mm)	Dia. "B" (mm)
8068	66,5	53,8
8069	69,9	57,2
8070	72,9	60,3
8071	76,2	63,5
8072	82,6	69,9
8073	88,9	76,2

**SHAFT PROTECTOR SET**

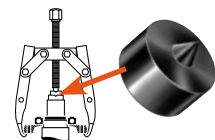

Power Team shaft protectors are designed to protect shaft centers from distortion when extreme pressures are applied with jaw-type pullers or Bi-Directional™ Pullers. Shaft protectors are inserted between the end of the puller screw and the shaft.

Order No.	Description
8056	Set of 6 shaft protectors (8050 thru 8055).

CONTENTS OF 8056 SET					CONTENTS OF 8056 SET				
Order No.	Dia. "A" (mm)	Dia. "B" (mm)	"C" (60°) (mm)	"D" (60°) (mm)	Order No.	Dia. "A" (mm)	Dia. "B" (mm)	"C" (60°) (mm)	"D" (60°) (mm)
8050	38,1	19,1	9,4	11,1	8053	19,1	19,1	6,4	6,4
8051	31,8	19,1	9,4	9,4	8054	15,7	15,7	6,4	6,4
8052	25,4	19,1	9,4	7,9	8055	15,7	15,7	4,8	4,8

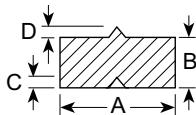

**CAUTION:** All the items shown may not withstand the full tonnage of the pullers they may be used with.

# RESOURCES

## GET INFORMED AND LEARN MORE ABOUT POWER TEAM PRODUCTS IN OUR RESOURCE SECTION

Power Team brings expertise to your application challenges in a variety of industries worldwide.

Within your resource section, you will have a variety of tools availability to select and capture information working around our products.

Power Team is a brand of Hydraulic Technologies. Based in Rockford, Illinois, Hydraulic Technologies' innovative, world-class products and highly-engineered solutions are helping to meet the needs of a constantly developing world and growing global population. You'll find our innovative solutions in everything from dairy plants and power plants to oil and gas pipelines, the power grid and bus fare collection systems. Hydraulic Technologies is really everywhere you look. We help our customers around the globe expand and enhance their food and beverage, power and energy and industrial production processes.

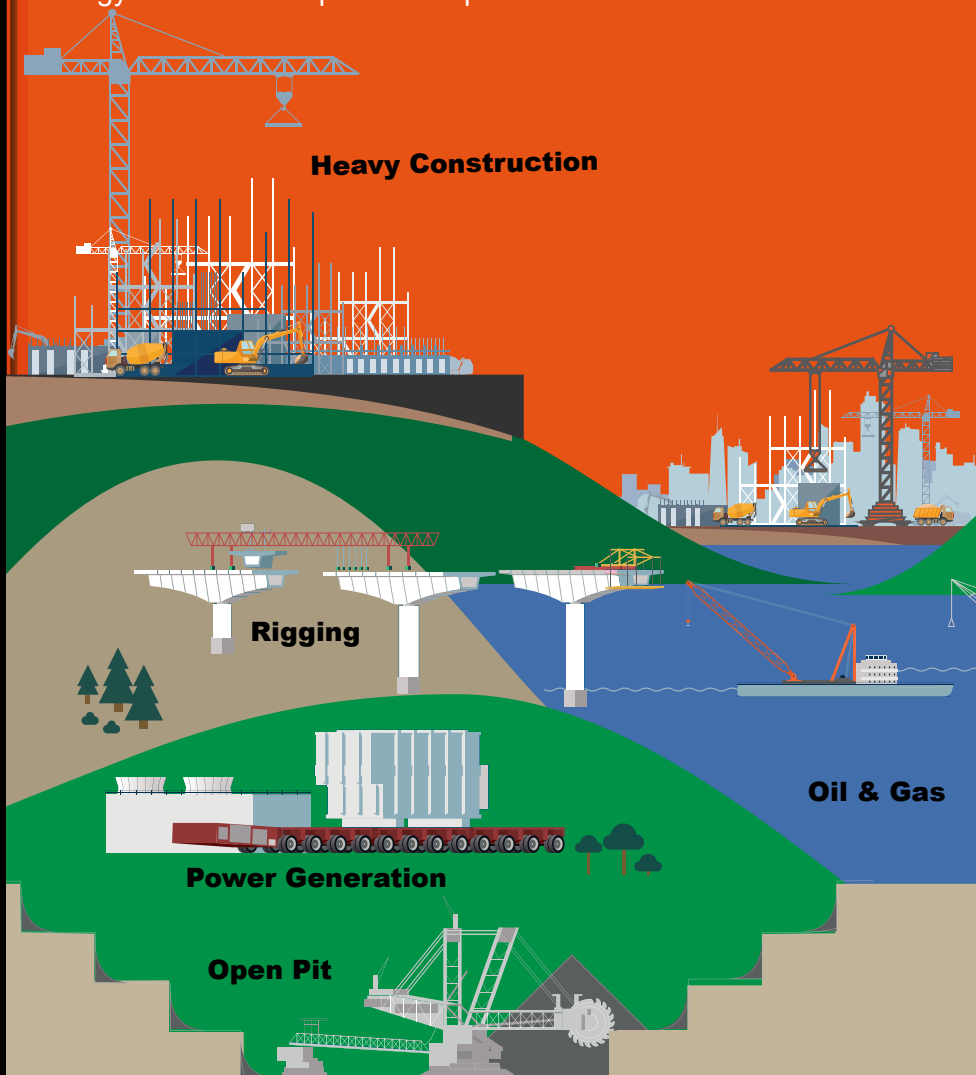

Powerthon  
Limited  
**Lifetime**  
WARRANTY  
ISO 9001 Certified

Worry-Free  
Ownership



	Section	Page(s)
	Manufacturing Standards	263
 	Warranty Overview	264
	Hydraulic Safety Insights	265-266
	Application Insights	267-268
	Hydraulic Circuits	269-270
	Formula Conversions	271-272
	System Arrangement Workbook	273-274
	Cylinder Seal Kit Reference Table	275-276
	Notes	281

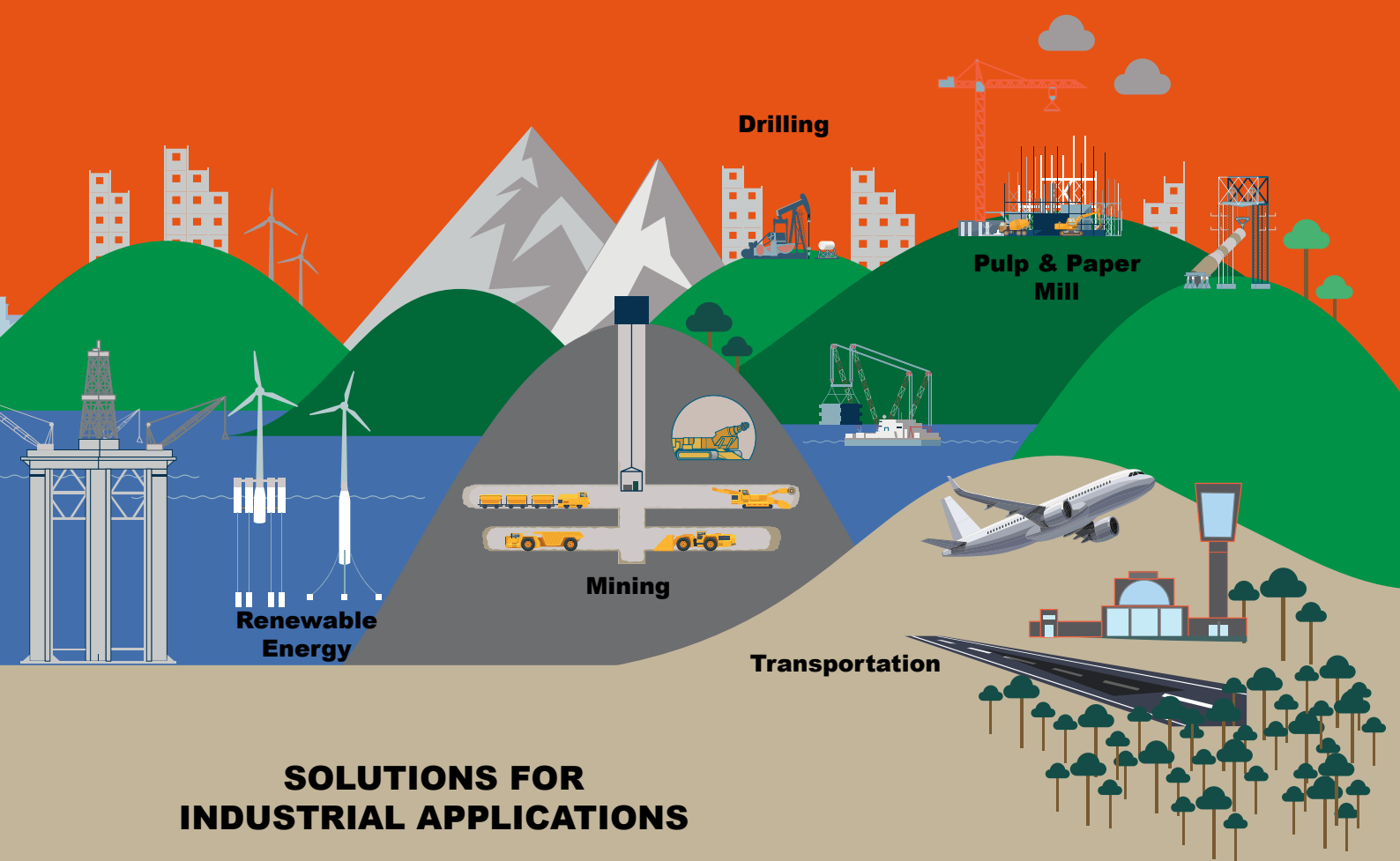

**SOLUTIONS FOR  
INDUSTRIAL APPLICATIONS**



The Hydraulic Technologies commitment to quality, through our Power Team brand, is evident in everything we do. From raw material receipt to how we support our customers years after they purchase our products. The Power Team brand is registered to ISO 9001 international quality standard, which requires compliance with standards for management, administration, product development, manufacturing and continuous improvement. Our registration verifies that the Hydraulic Technologies has adopted and maintains documentation for processes ranging from suppliers to customers, inspection, handling and training. ISO 9001 also requires periodic internal and external audits to ensure all aspects of work affecting quality control are monitored.

#### ASME B30.1

Power Team hydraulic cylinders comply with the criteria set forth in the American Society of Mechanical Engineers standard ASME B30.1: Cylinders are tested at 125 percent of rated pressure at full travel and are inspected to assure functionality and freedom from leaks.

#### ASME B40.1

Power Team heavy-duty pressure gauges are designed in accordance with the recommendations set forth in the American Society of Mechanical Engineers standard ASME B40.1, Grade B.

#### CE Mark

Hydraulic Technologies is committed to designing, manufacturing and marketing products that meet or exceed the needs of the customers we serve. Power Team supplies a Declaration of Incorporation (for Partly Completed Machinery only) or a Declaration of Conformity and CE Marking for products that are within the scope and conform to at least one European Community CE Directive. Note: Not all products are within such scope and subsequently may not be allowed to carry a CE mark. If the CE mark is required or requested, please contact the factory for clarification and note that it must be requested at the time a product is ordered.

#### CSA

Where specified in our literature and catalogs and on our web site, Power Team electric power pump assemblies meet the design, assembly and test requirements of the Canadian Standards Association. Note: If CSA certification is required, it must be requested at the time a Power Team pump is ordered.

#### NEMA

Where specified in our literature and catalogs and on our web site, Power Team electric power pump assemblies meet the design, assembly and test requirements of NEMA 12, a National Electrical Manufacturers' Association standard relating to electrical components used to resist moisture and dust. Note: If NEMA certification is required, it must be requested at the time a Power Team brand pump is ordered.

#### Product Design Criteria

All Power Team hydraulic components are designed and/or tested to be safe for use at maximum operating pressures of 700 bar unless otherwise specifically noted in our literature and catalogs and on our web site.

#### Quality Assurance

All of Power Team hydraulic cylinders are subjected to quality checks during production. All steel bar is certified and has material traceability to the mill. Before leaving the factory, all cylinders are pressure tested to 875 bar except the RT series, which are tested to 700 bar to insure on-the-job reliability.



“Power Team” is a registered trademark of the Hydraulic Technologies Hydraulic Technologies division of Hydraulic Technologies Inc. (“Hydraulic Technologies”). All Power Team products and parts, with the exceptions noted below, are warranted against defects in materials and workmanship for the life of the product or part. (The life of the product or part is defined as that point in time when it no longer safely or properly functions due to normal wear). Inflatable jacks, chains, batteries, electric motors, gas engines, knives and cutter blades which are sold with Power Team products are not covered by this warranty and instead are warranted as follows:

Inflatable jacks and electronics are warranted against defects in materials and workmanship for a period of one year from date of purchase.

Consumable parts or accessories, including without limitation, chains, batteries, knives and cutter blades are warranted against defects in materials and workmanship for a period of one year from date of purchase.

All electric motors and gas engines are separately warranted by their respective manufacturer under the terms and conditions stated in their separate warranty.

The foregoing warranties do not cover ordinary wear and tear or any product or part that has been worn out, abused, heated, ground or otherwise altered, used for a purpose other than that for which it was intended or used in a manner inconsistent with any instructions regarding its use.

To qualify for warranty consideration, return the Power Team product, freight prepaid, to a Power Team authorized repair center or to the Hydraulic Technologies factory. If any product or part manufactured by Hydraulic Technologies found to be defective by Hydraulic Technologies, in its sole judgment, Hydraulic Technologies will, at its option, either repair or replace such defective product or part and return it via best ground transportation, freight prepaid. **THIS REMEDY SHALL BE THE EXCLUSIVE REMEDY AVAILABLE FOR ANY DEFECTS IN THE PRODUCTS OR PARTS MANUFACTURED AND SOLD BY Hydraulic Technologies OR FOR DAMAGES RESULTING FROM ANY OTHER CAUSE WHATSOEVER, INCLUDING WITHOUT LIMITATION, Hydraulic Technologies’S NEGLIGENCE. Hydraulic Technologies SHALL NOT, IN ANY EVENT, BE LIABLE TO ANY BUYER FOR CONSEQUENTIAL OR INCIDENTAL DAMAGES OF ANY KIND, WHETHER FOR DEFECTIVE OR NON-CONFORMING GOODS, NEGLIGENCE, ON THE BASIS OF STRICT LIABILITY OR FOR ANY OTHER REASON.**

Hydraulic Technologies’s PowerThon™ Warranty is expressly limited to persons who purchase Power Team products or parts for the resale or for use in the ordinary course of the buyer’s business.

**THIS WARRANTY IS EXCLUSIVE, AND Hydraulic Technologies MAKES NO OTHER WARRANTY OF ANY KIND WHATSOEVER, EXPRESSED OR IMPLIED, WITH RESPECT TO THE PRODUCTS MANUFACTURED AND SOLD BY IT, WHETHER AS TO MERCHANT-ABILITY, FITNESS FOR A PARTICULAR PURPOSE, OR ANY OTHER MATTER.** No agent, employee, or representative of Hydraulic Technologies has any authority to bind Hydraulic Technologies to any affirmation, representation, or warranty concerning Power Team products or parts, except as stated herein.

The purpose of this exclusive remedy shall be to provide the buyer with repair or replacement of products or parts manufactured by Hydraulic Technologies found to be defective in materials or workmanship or negligently manufactured. This exclusive remedy shall not be deemed to have failed of its essential purpose so long as Hydraulic Technologies is willing and able to replace said defective products or parts in the prescribed manner. Any inconsistent terms contained in Hydraulic Technologies’s Standard Terms and Conditions, or other Hydraulic Technologies terms or warranty documents shall not be interpreted to modify or limit this PowerThon™ Warranty. For the avoidance of doubt, this PowerThon™ Warranty is applicable only to Power Team products and does not apply to any other Hydraulic Technologies products.



Wear appropriate Personal Protective Equipment (PPE).

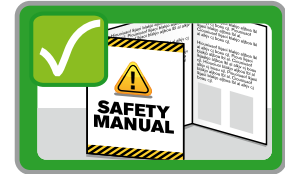

Read all instructions.



Do not exceed the rated load of any pump, tool or component.



Inspect all components before use. Do not use damaged or worn components. Return to an Authorized Repair Center for repair or replacement.

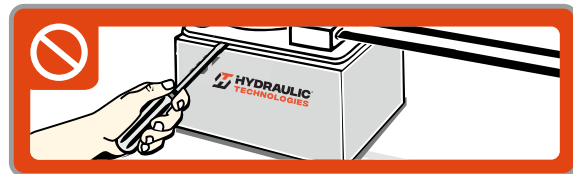

Never alter internal relief valves.

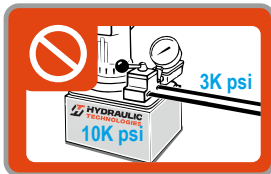

Recognize system pressures. Do not use a 700 bar pump on a system with 207 bar components (hoses, fittings, valves, tools, etc.).

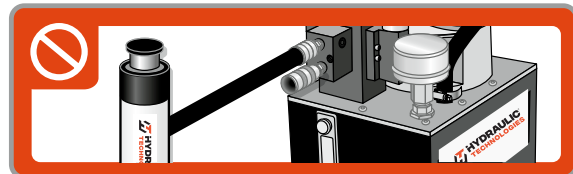
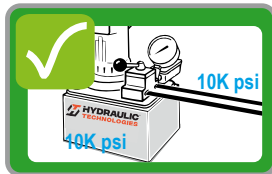

Do not use pumps designed for torque wrenches or tensioners for lifting.



Do not overfill pump reservoirs.



Use only high quality oil, like SPX Power Team hydraulic oil. Using the wrong fluid can lead to equipment damage and premature failure.



Do not use the same oil in all equipment and in all environments.



Change oil and/or filters at appropriate intervals.

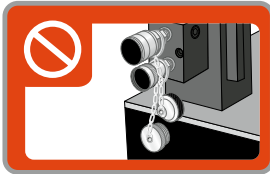

Do not operate a pump with couplers exposed or uncapped.

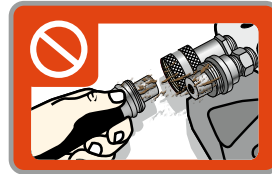
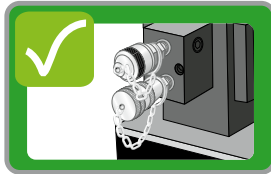

Clean both ends of the couplers before assembly.



Do not kink hydraulic hoses.

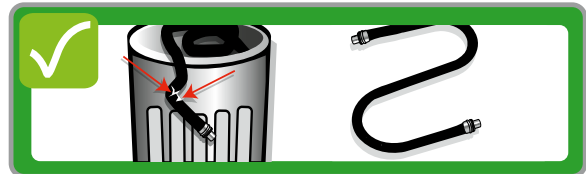

Replace damaged hoses immediately.



Keep equipment away from excessive temperatures. Do not weld next to unprotected equipment.



Keep couplers capped when not in use.



Do not drive over hoses or drop objects onto them.

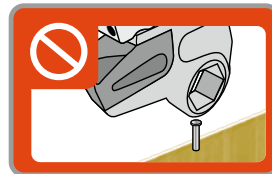

Only use tools for their intended purpose.

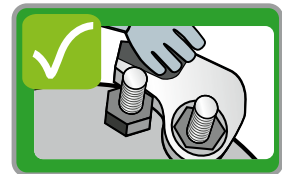

Keep hands clear of pinch points.

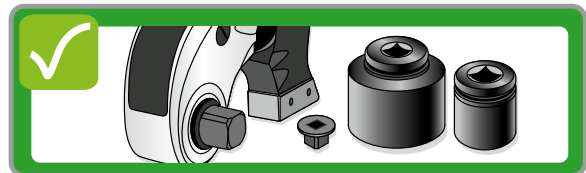
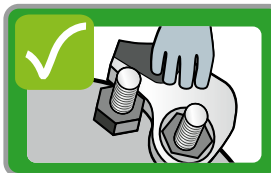

Only use high quality impact sockets and reducers with an appropriate load rating and safety factor.

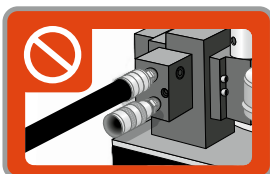

Always connect both torque wrench hoses to the pump. Do not operate with only one hose attached.

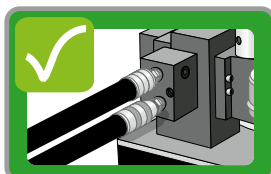

Use only the proper size sockets and links.





**Application / Industry Highlight**

Cement Plant, Manufacturing

**Situation:**

Customer asked for 91 Ton Heavy-Duty bearing puller, working with 50Hz power source with a global company. The application required removing bearings and gears in maintenance of shafts and rolling parts.

**Solution:**

Supplied 91T Puller # PTPH-100T-50-220

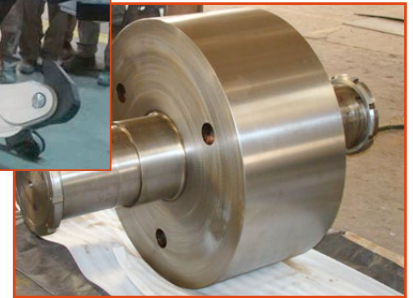
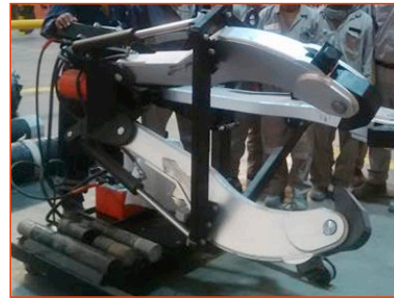

**Application / Industry Highlight**

Railcar Maintenance, Rail

**Situation:**

Customer needing a more reliable way to lift empty rail cars to install wheels. The cars are empty, but require fast speed for lifting. The standard RJ100T37E was slower than customer desired.

**Solution:**

RJ100T37E modified with a PE1204FR pump

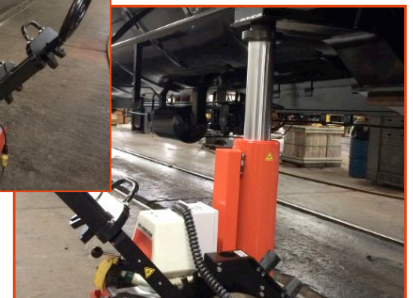
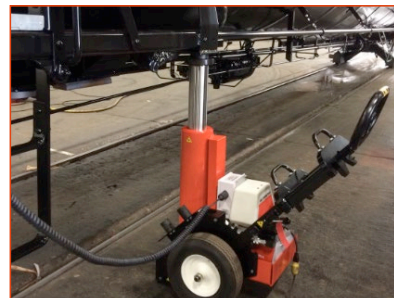

**Application / Industry Highlight**

Shipbuilding / Repair, Transportation

**Situation:**

Customer manufactures propeller shafts for large military vessels (Air Craft Carriers, Destroyers, etc). Having trouble with concentricity of dissimilar metals pulling apart during welding process, they needed something to keep them clamped.

**Solution:**

8-PH82K pullers



**Application / Industry Highlight**  
Construction, New Bridge Construction

**Situation:**  
Bridge Replacement site in Raritan River, NJ to lower the multiple cofferdams. New concrete piers were installed using the cofferdams to make way for supporting the bridge. Requirements; less than 4mm tolerance from point to point during the lowering process.

**Solution:**  
2 - 8 Point Motion Control System (MCS) consisting of 2 - 8 point skids (each with a PQ120 pump)  
16-RH10010 10" 91T center hole double acting cylinders.

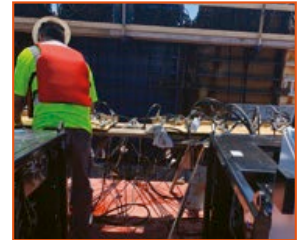
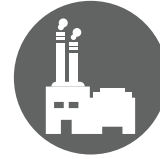

**Application / Industry Highlight**  
Power Plant, Energy

**Situation:**  
The incinerated coal is mixed with water and transported through several pipelines to the repository by very powerful pumps. These pipelines have flanges of various sizes. These flanges must be opened in certain periods and the seals must be changed.

**Solution:**  
Hydraulic Torque Wrench set  
(TWHC1, TWHC3, PE55)



**Application / Industry Highlight**  
Copper Mine, Mining

**Situation:**  
Customer needed to lift this 617 Ton structure in a synchronized manner to replace the six-ton slewing bearing for this ship loader.

**Solution:**  
Supplied one Motion Control System and 3 - 254 Ton Lock Nut Cylinders

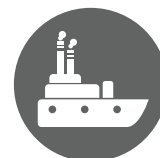



Countless applications are possible with Power Team hydraulic components. From pressing, lifting, and jacking applications to production or maintenance setups. The diagrams are typical electric/hydraulic units. Electric, air or gas-driven pumps are available.

**Single-acting cylinder or cylinders in the circuit, controlled by a pump-mounted valve.**

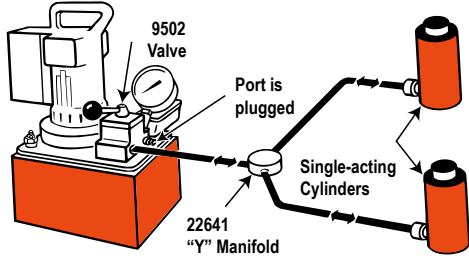

**Double-acting cylinder or cylinders in the circuit, controlled by a pump-mounted valve.**

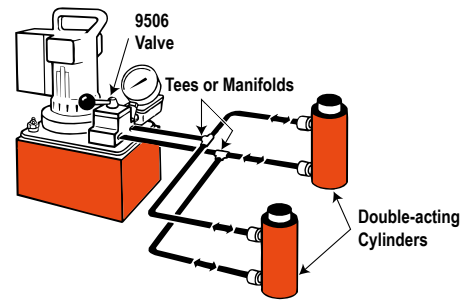

**Single-acting cylinder controlled by a remote-mounted valve.**

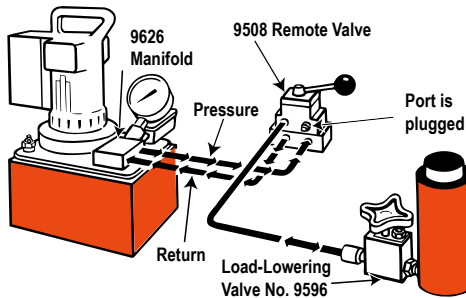

**Double-acting cylinders controlled by a remote-mounted valve.**

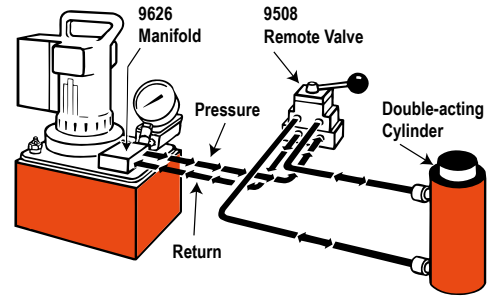

**Single-acting cylinders with a sequence valve which controls the primary and secondary cylinder circuits.**

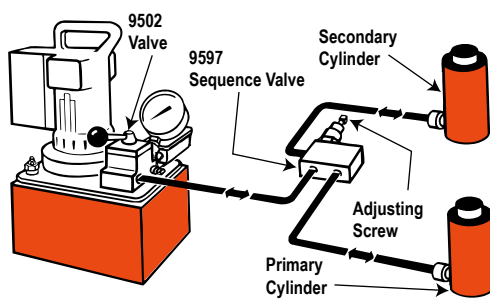

**Double-acting cylinder with a sequence valve which controls the primary and secondary cylinder circuits.**

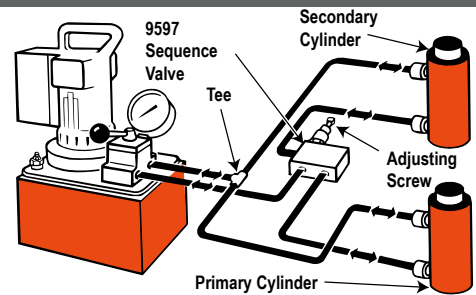

## Hydraulic Circuit Components

- 1 Cylinder** – applies hydraulic force.
- 2 Pump** – a device for converting mechanical energy to fluid energy.
- 3 Directional valve** – controls the direction of hydraulic fluid in the system.
- 4 Gauge** – measures pressure (PSI - Pounds per Square Inch) and/or force.
- 5 Hose** – transports hydraulic fluid.
- 6 Manifold** – allows distribution of hydraulic fluid from one source to several cylinders. (9617)
- 7 Swivel Connector** – allows proper alignment of valves and/or gauges. Used when units being connected cannot be rotated. (9675)
- 8 Quick Coupling** – “hose half” and “cylinder half” couplings are used for quick-connection and fluid flow check when separated. (9797 and 9798)
- 9 Shut-Off Valve** – regulates the flow of hydraulic fluid to or from cylinders. (9642 or 9644)
- 10 Load-Lowering Valve** – allows metered lowering of cylinder and provides safety when prolonged load holding is required. (9596)
- 11 T-Gauge Adapter** – allows for installation of pressure/tonnage gauge anywhere in the hydraulic system. (9670)
- 12 Pipe Plug** – for blocking unused ports within the system. (9687)

**Basic single-acting system with a hand pump, gauge, hose, multiple shut-off valves, load-lowering valves and multiple cylinders.**

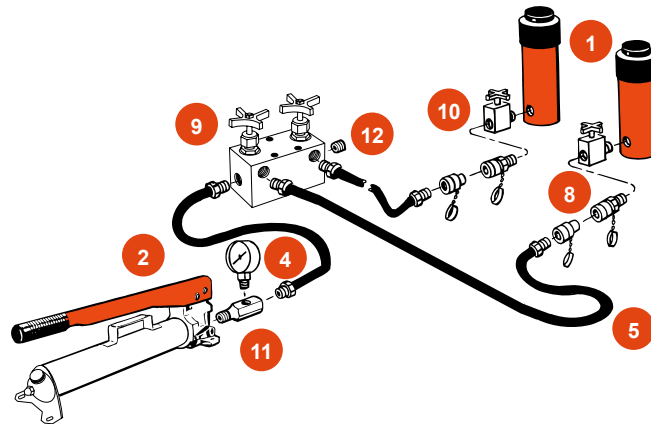

**Basic double-acting system with an electric/hydraulic pump, shut-off valves, load-lowering valves and multiple double-acting cylinders.**

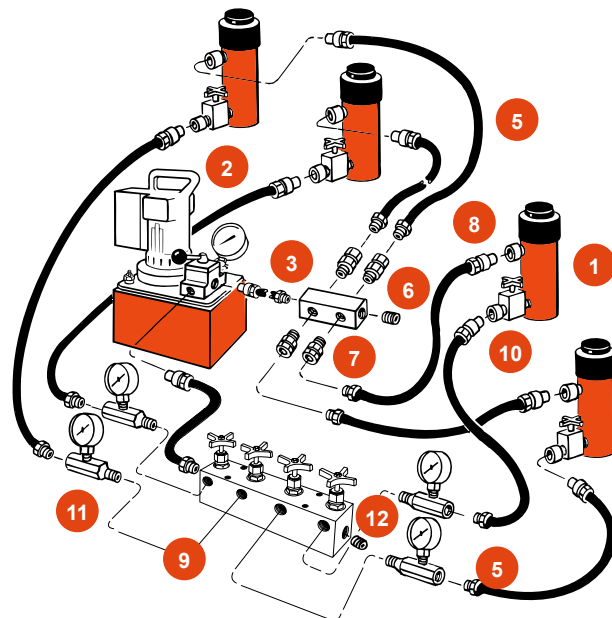



FRACTION	DECIMALS	MILLIMETERS	FRACTION	DECIMALS	MILLIMETERS
1/64	.015625	0,397	33/64	.515625	13,097
1/32	.03125	0,794	17/32	.53125	13,494
3/64	.046875	1,191	35/64	.546875	13,891
1/16	.0625	1,588	9/16	.5625	14,288
5/64	.078125	1,984	37/64	.578125	14,684
3/32	.09375	2,381	19/32	.59375	15,081
7/64	.109375	2,778	39/64	.609375	15,478
1/8	.1250	3,175	5/8	.6250	15,875
9/64	.140625	3,572	41/64	.640625	16,272
5/32	.15625	3,969	21/32	.65625	16,669
11/64	.171875	4,366	43/64	.671875	17,066
3/16	.1875	4,763	11/16	.6875	17,463
13/64	.203125	5,159	45/64	.703125	17,859
7/32	.21875	5,556	23/32	.71875	18,256
15/64	.234375	5,953	47/64	.734375	18,653
1/4	.2500	6,350	3/4	.7500	19,050
17/64	.265625	6,747	49/64	.765625	19,447
9/32	.28125	7,144	25/32	.78125	19,844
19/64	.296875	7,541	51/64	.796875	20,241
5/16	.3125	7,938	13/16	.8125	20,638
21/64	.328125	8,334	53/64	.828125	21,034
11/32	.34375	8,731	27/32	.84375	21,431
23/64	.359375	9,128	55/64	.859375	21,828
3/8	.3750	9,525	7/8	.8750	22,225
25/64	.390625	9,922	57/64	.890625	22,622
13/32	.40625	10,319	29/32	.90625	23,019
27/64	.421875	10,716	59/64	.921875	23,416
7/16	.4375	11,113	15/16	.9375	23,813
29/64	.453125	11,509	61/64	.953125	24,209
15/32	.46875	11,906	31/32	.96875	24,606
31/64	.484375	12,303	63/64	.984375	25,003
1/2	.5000	12,700	1	1.000	25,400

NOTE: 1 mm = .03937" .001" = .0254 mm



	<b>MULTIPLY SI* UNIT</b>	<b>BY CONVERSION FACTOR</b>	<b>TO GET OR MULTIPLY NON-SI UNIT</b>	<b>BY CONVERSION FACTOR</b>	<b>TO GET SI* UNIT</b>
LENGTH	Millimeter (mm)	X 0,03937	= inch	X 25,4	= mm (1 inch = 25.4 mm exactly)
	Centimeter (cm) 10 mm	X 0,3937	= inch	X 2,54	= cm
	Meter (m) 1000 mm	X 3,28	= foot	X 0,305	= m
	meter (m)	X 1,09	= yard	X 0,914	= m
	kilometer (km) 1000 m	X 0,62	= mile	X 1,61	= km
AREA	millimeter <sup>2</sup> (mm <sup>2</sup> )	X 0,00155	= inch <sup>2</sup>	X 645	= mm <sup>2</sup>
	centimeter <sup>2</sup> (cm <sup>2</sup> )	X 0,155	= inch <sup>2</sup>	X 6,45	= cm <sup>2</sup>
	meter <sup>2</sup> (m <sup>2</sup> )	X 10,8	= foot <sup>2</sup>	X 0,0929	= m <sup>2</sup>
	meter <sup>2</sup> (m <sup>2</sup> )	X 1,2	= yard <sup>2</sup>	X 0,836	= m <sup>2</sup>
	hectare (ha) 10,000 m <sup>2</sup>	X 2,47	= acre	X 0,405	= ha
	kilometer <sup>2</sup> (km <sup>2</sup> )	X 0,39	= mile <sup>2</sup>	X 2,59	= km <sup>2</sup>
VOLUME	centimeter <sup>3</sup> (cm <sup>3</sup> )	X 0,061	= inch <sup>3</sup>	X 16,4	= cm <sup>3</sup>
	liter (L)	X 61	= inch <sup>3</sup>	X 0,016	= L
	milliliter (mL)	X 0,034	= oz-liq	X 29,6	= mL (1 mL = 1 cm <sup>3</sup> )
	liter (L) 1000 mL	X 1,06	= quart	X 0,946	= L
	liter (L)	X 0,26	= Gallon	X 3,79	= L
	meter <sup>3</sup> (m <sup>3</sup> ) 1000 L	X 1,3	= yard <sup>3</sup>	X 0,76	= m <sup>3</sup>
MASS	Gram (g)	X 0,035	= ounce	X 28,3	= g
	kilogram (kg) 1000 g	X 2,2	= pound	X 0,454	= kg
	metric ton (t) 1000 kg	X 1,1	= ton (short)	X 0,907	= t
FORCE	Newton (N)	X 0,225	= pound	X 4,45	= N
	kilo-newton (kN)	X 225	= pound	X 0,00445	= kN
	newton meter (Nm)	X 8,9	= lb. in.	X 0,113	= Nm
	newton meter (Nm)	X 0,74	= lb. ft.	X 1,36	= Nm
PRESSURE	kilo-pascal (kPa)	X 4,0	= in. H <sub>2</sub> O	X 0,249	= kPa
	kilo-pascal (kPa)	X 0,30	= in. Hg	X 3,38	= kPa
	kilo-pascal (kPa)	X 0,145	= psi	X 6,89	= kPa
	mega-pascal (MPa)	X 145	= psi	X 0,00689	= MPa
	bar	X 14,5	= psi	X 0,0680	= bar
POWER	kilowatt (kw)	X 1.34	= hp	X 0,746	= kw
	kilowatt (kw)	X 0.948	= Btu/s	X 1,055	= kw
	watt (w)	X 0.74	= ft. lb/s	X 1,36	= w
FLOW	cu cm/min	X 0.061	= cu in/min	X 16,4	= cu cm/min
	liters/min	X 0.2642	= GPM	X 3,785	= liters/min

**\* SYSTEM INTERNATIONAL (MODERN METRIC SYSTEM)**



Selecting the appropriate equipment for your application can be accomplished by following these three steps.

**1) Understanding the “Pain Points”**



**2) Connect “Application” to a Function**



**3) Select the correct tool for the function required**



**STEP 1: Determine the type of lift or tool required for your application:**

- Single or multiple-point lift?
- Balanced or unbalanced load?
- Guided or unguided load?
- Pulling, pressing, punching, spreading or torquing?

**STEP 2: Choose the right cylinder or tool for your specific application:**

- Determine the force required. (Power Team recommends using 80% of the rated capacity and stroke to maximize product performance and safety.)
- Determine the total amount of oil required for each cylinder(s) and/or tool(s).
- Determine the closed height, stroke requirement and diameter footprint allowable.
- Push and/or pull requirement. For cylinders, single-acting, load return, spring return or double-acting hydraulically driven both ways.

**STEP 3: Choose the right pump source for your application based on your cylinder /tools and oil / speed requirements:**

- What is the maximum system operating pressure requirement?
- What is the volume of oil required? Add all of the cylinder(s) and/or tool(s) cubic volume requirements and add 1 cubic inch per 1.66 foot of hose.
- What is the preferred source of power? (hand, air, electric, or gas). If hand pump is selected, choose between single or two-speed.
- Do you need this to be portable? (consider weight and size).







Cylinder Order Number	Seal Kit*
C51C	300404
C53C	300404
C55C	300404
C57C	300404
C59C	300404
C101C	300116
C102C	300116
C104C	300116
C106C	300116
C108C	300116
C1010C	300116
C1012C	300116
C1014C	300116
C1016C	300116
C151C	300453
C152C	300453
C154C	300453
C156C	300453
C158C	300453
C1510C	300453
C1512C	300453
C1514C	300453
C1516C	300453
C251C	300147
C252C	300147
C254C	300147
C256C	300147
C258C	300147
C2510C	300147
C2512C	300147
C2514C	300147
C552C	300114
C554C	300114
C556C	300114
C5510C	300114
C5513C	300114
C756C	300647
C7513C	300647
C1002C	300112
C1006C	300112
C10010C	300112
C55CBT	300404
C106CBT	300116
C256CBT	300147

Cylinder Order Number	Seal Kit*
R1502C	300676
R1506C	300676
R15010C	300676
R2002C	300677
R2006C	300677
R20010C	300677
R2802C	300678
R2806C	300678
R28010C	300678
R3552C	300679
R3556C	300679
R35510C	300679
R4302C	300680
R4306C	300680
R43010C	300680
R5652C	300681
R5656C	300681
R56510C	300681
R1002D	300928
R1006D	300928
R10010D	300928
R1502D	300929
R1506D	300929
R15010D	300929
R2002D	300930
R2006D	300930
R20010D	300930
R2802D	300931
R2806D	300931
R28010D	300931
R3552D	300932
R3556D	300932
R35510D	300932
R4302D	301047
R4306D	301047
R43010D	301047
R5652D	300681
R5656D	300681
R56510D	300681
R552L	300674
R556L	300674
R5510L	300674
R1002L	300675
R1006L	300675

Cylinder Order Number	Seal Kit*
R10010L	300675
R1502L	300676
R1506L	300676
R15010L	300676
R2002L	300677
R2006L	300677
R2008L	300677
R20010L	300677
R2802L	300678
R2806L	300678
R28010L	300678
R3552L	300679
R3556L	300679
R35510L	300679
R4302L	300680
R4306L	300680
R43010L	300680
R5652L	300681
R5656L	300681
R56510L	300681
RA202	300631
RA204	300631
RA206	300631
RA302	300632
RA304	300632
RA306	300632
RA552	300391
RA554	300391
RA556	300391
RA5510	300391
RA1002	300444
RA1006	300444
RA10010	300444
RA556L	300395
RA1006L	300396
RD106	300017
RD1010	300017
RD256	300018
RD2514	300018
RD556	300005
RD5513	300005
RD5518	300005
RD8013	300410
RD1006	300120

Cylinder Order Number	Seal Kit*
RD10013	300120
RD10020	300120
RD1506	300007
RD15013	300007
RD15018	300007
RD2006	300008
RD20013	300008
RD3006	300466
RD30013	300466
RD4006	300467
RD40013	300467
RD5006	300468
RD50013	300468
RDG552	3000906
RDG554	3000906
RDG556	3000906
RDG558	3000906
RDG5510	3000906
RDG5512	3000906
RDG5513	3000906
RDG5514	3000906
RDG752	3000908
RDG754	3000908
RDG756	3000908
RDG758	3000908
RDG7510	3000908
RDG7512	3000908
RDG7513	3000908
RDG7514	3000908
RDG1002	3000876
RDG1004	3000876
RDG1006	3000876
RDG1008	3000876
RDG10010	3000876
RDG10012	3000876
RDG10013	3000876
RDG10014	3000876
RDG1502	3000881
RDG1504	3000881
RDG1506	3000881
RDG1508	3000881
RDG15010	3000881
RDG15012	3000881
RDG15013	3000881

\* Nitrile seals comes standard on all cylinders.



Cylinder Order Number	Seal Kit*
RDG15014	3000881
RDG2002	3000891
RDG2004	3000891
RDG2006	3000891
RDG2008	3000891
RDG20010	3000891
RDG20012	3000891
RDG20013	3000891
RDG20014	3000891
RDG2502	3000911
RDG2504	3000911
RDG2506	3000911
RDG2508	3000911
RDG25010	3000911
RDG25012	3000911
RDG25013	3000911
RDG25014	3000911
RDG3002	3000920
RDG3004	3000920
RDG3006	3000920
RDG3008	3000920
RDG30010	3000920
RDG30012	3000920
RDG30013	3000920
RDG30014	3000920
RDG4002	3000903
RDG4004	3000903
RDG4006	3000903
RDG4008	3000903
RDG40010	3000903
RDG40012	3000903
RDG40013	3000903
RDG40014	3000903
RDG5002	3000921
RDG5004	3000921
RDG5006	3000921
RDG5008	3000921
RDG50010	3000921
RDG50012	3000921
RDG50013	3000921
RDG50014	3000921
RDG6002	3000901
RDG6004	3000901
RDG6006	3000901

Cylinder Order Number	Seal Kit*
RDG6008	3000901
RDG60010	3000901
RDG60012	3000901
RDG60013	3000901
RDG60014	3000901
RGG556	3001016
RGG558	3001016
RGG5510	3001016
RGG5512	3001016
RGG5513	3001016
RGG5514	3001016
RGG752	3001049
RGG754	3001049
RGG756	3001049
RGG758	3001049
RGG7510	3001049
RGG7512	3001049
RGG7513	3001049
RGG7514	3001049
RGG1002	3001018
RGG1004	3001018
RGG1006	3001018
RGG1008	3001018
RGG10010	3001018
RGG10012	3001018
RGG10013	3001018
RGG10014	3001018
RGG1502	3001019
RGG1504	3001019
RGG1506	3001019
RGG1508	3001019
RGG15010	3001019
RGG15012	3001019
RGG15013	3001019
RGG15014	3001019
RGG2002	3001050
RGG2004	3001050
RGG2006	3001050
RGG2008	3001050
RGG20010	3001050
RDG20012	3001050
RGG20013	3001050
RGG20014	3001050
RGG2502	3001051

Cylinder Order Number	Seal Kit*
RGG2504	3001051
RGG2506	3001051
RGG2508	3001051
RGG25010	3001051
RGG25012	3001051
RGG25013	3001051
RGG25014	3001051
RGG3002	3001022
RGG3004	3001022
RGG3006	3001022
RGG3008	3001022
RGG30010	3001022
RGG30012	3001022
RGG30013	3001022
RGG30014	3001022
RGG4002	3001023
RGG4004	3001023
RGG4006	3001023
RGG4008	3001023
RGG40010	3001023
RGG40012	3001023
RGG40013	3001023
RGG40014	3001023
RGG5002	3001024
RGG5004	3001024
RGG5006	3001024
RGG5008	3001024
RGG50010	3001024
RGG50012	3001024
RGG50013	3001024
RGG50014	3001024
RGG6002	3001025
RGG6004	3001025
RGG6006	3001025
RGG6008	3001025
RGG60010	3001025
RGG60012	3001025
RGG60013	3001025
RGG60014	3001025
RH102	300071
RH108	300071
RH120	300657
RH121	300576
RH121T	300576

Cylinder Order Number	Seal Kit*
RH123	300576
RH202	300615
RH203	300069
RH206	300615
RH302	300037
RHA306	300867
RH306	300037
RH503	300059
RH603	300477
RH606	300477
RH1003	300485
RH303	300077
RH306D	300822
RH3010	300625
RHA604D	300269
RH605	300269
RH6010	300626
RH1001	300927
RH1006	300295
RH10010	300629
RH1505	300154
RH1508	300583
RH2008	300582
RLS50	300454
RLS100	300455
RLS200	300456
RLS300	300457
RLS500S	300458
RLS750S	300459
RLS1000S	300460
RLS1500S	300461
RP25	300628
RP55	300627
RSS101	300010
RSS202	300011
RSS302	300297
RSS502	300292
RSS1002	300293
RSS2503	—
RSS1002D	300578
RT172	300358
RT302	300359
RT503	300360
RT1004	300024

\* Nitrile seals comes standard on all cylinders.





## POWER TEAM TECHNICAL TRAINING ACADEMY

### On-site Safety Training

Workplace safety should be a high priority to assure high-pressure hydraulic tools are used in accordance with recommended safety procedures. Safety Training Seminars demonstrate the proper methods for operating high-pressure hydraulic tools to avoid equipment damage and lost time accidents. Hydraulic Technologies offers two different safety seminars: Hydraulic Safety and Puller Safety.

**Hydraulic Safety:** Hydraulic components operating high pressures (10,000 psi/700 bar) give you the advantages of compact size and portability, but any high-force equipment needs to be used safely and sensibly. After attending this informative session, you will be combined of techniques and requirements to inspect, connect, and operate high-force tools in a safe manner.

**Puller Safety:** This program presents the three basic pulling problems and the safe solutions for using jaw-type pullers, push-pullers, hydraulically powered pullers, specialty pullers, and puller adapters and accessories. After attending, you will know the proper steps required to safely select and operate the best puller for the job.

### Factory Maintenance & Repair Training

Maintaining Hydraulic Technologies products in good operating condition enhances operating efficiency and extends service life. This seminar explains the proper methods for keeping your products operating at peak levels of performance and reliability. Topics include understanding hydraulic circuits, product maintenance, troubleshooting, and field repairs. The three-to-five-day seminar is structured to meet your product knowledge requirements.

**For a list of available dates, visit <https://hydraulictechnologies.com/training>**



Lifting

Lowering



Pulling

Pushing



Turning

Bending



Cutting

Spreading



## CUSTOMER SERVICE & SUPPORT

### Europe

Tel: +31 45 567 8877  
info.emea@hytec.com

### Americas

Tel: +1 800 541 1418  
info.amer@hytec.com

### Bolting Rental

Tel: 1-713-472-2500 (Pasadena, TX)  
Tel: 1-361-445-3727 (Corpus Christi, TX)  
Tel: 1-225-774-0888 (Gonzales, LA)  
bolting.amer@hytec.com

### Rail Systems

Tel: +44 208 526 7100  
info.rail@hytec.com

### Asia Pacific

Tel: +86 21 6715 0078 (China)  
Tel: +61 03 6164 7933 (Australia)  
Tel: +65 6264 4366 (Singapore)  
info.apac@hytec.com

### Bolting Rental

Tel: +65 6265 4366  
bolting.apac@hytec.com

To learn more, visit us at  
[hydraulictechnologies.com](http://hydraulictechnologies.com)

Distributed by:



Hydraulic Technologies reserves the right to incorporate our latest design and material changes without notice or obligation. Design features, materials of construction and dimensional data, as described in this bulletin, are provided for your information only and should not be relied upon unless confirmed in writing. Please contact your local sales representative for product availability in your region.